



Service Manual

GREE ELECTRIC APPLIANCES, INC. OF ZHUHAI



Table of Contents

Part I : Technical Information	1
1. Summary	1
2. Specifications	2
3. Outline Dimension Diagram	5
4. Refrigerant System Diagram	6
5. Electrical Part	7
5.1 Wiring Diagram	7
5.2 PCB Printed Diagram	8
6. Function and Control	9
6.1 Wired Controller for XE73-44/E	9
6.2 Brief Description of Models and Functions	27
Part II : Installation and Maintenance	28
7. Notes for Installation and Maintenance	28
8. Installation	29
8.1 Dimension Requirements on the Installation Space of the Indoor Unit...29	
8.2 Installation of the Indoor Unit	30
8.3 Horizontality Check of the Indoor Unit	31
8.4 Installation of the Air Supply Duct	31
8.5 Drawings of the Air Supply Outlet and Return Air Inlet	32
8.6 Installation of the Return Air Duct	32
8.7 Installation of the Condensate Pipe	33
8.8 Design of the Drain Pipe	33
8.9 Installation of the Drain Pipe	33
8.10 Precautions for the Lift Pipe	34
8.11 Test for the Drainage System	35

8.12 Piping	35
8.13 Insulation for the refrigerant pipe	36
8.14 Wiring between the Wire and the Wiring Terminal	36
8.15 Wiring of the Power Cord (single-phase)	37
8.16 Installation and Dismantlement for Wired Controller	38
9. Maintenance	40
9.1 Error Code List	40
9.2 Procedure of Troubleshooting	42
10. Exploded View and Parts List	53
11. Removal Procedure	57

1. Summary

Indoor Unit:

GFH(09)CA-D6DNA1C/I GFH(12)CA-D6DNA1C/I GFH(18)CB-D6DNA1C/I

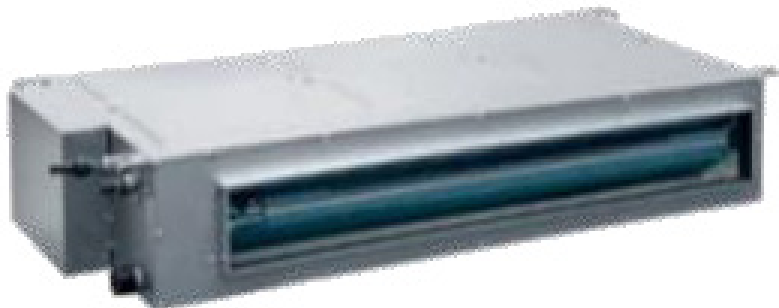

Model list:

No.	Model	Product code
1	GFH(09)CA-D6DNA1C/I	CN210N0300
2	GFH(12)CA-D6DNA1C/I	CN210N0280
3	GFH(18)CB-D6DNA1C/I	CN210N0290

2. Specifications

Parameter		Unit	Value
Model			GFH(09)CA-D6DNA1C/I
Product Code			CN210N0300
Power Supply	Rated Voltage	V~	220
	Rated Frequency	Hz	60
	Phases		1
Cooling Capacity		W	2650
Heating Capacity		W	2800
Air flow volume		m ³ /h	560/450/340/220
Dehumidifying Volume		L/h	0.8
Fan Type			Centrifugal
Fan Diameter-height		mm	Φ138.6-143
Fan Motor Speed		rpm	Cooling:950/830/710/600 Heating:950/830/710/600
Fan Motor Power Output		W	20
Fan Motor Power Input		W	65
Motor Full Load Amp(FLA)		A	/
Fan Motor Capacitor		μF	2
Evaporator Material			Inner Groove Copper Tube-Aluminum fin
Evaporator Pipe Diameter		mm	Φ5
Evaporator Number of Rows-Fin Pitch		mm	2-1.4
Evaporator Length(L)XHeight(H)XWidth(W)		mm	547X228.6X22.8
Fuse Current		A	5
Sound Pressure Level		dB (A)	32/28/25/22
Sound Power Level		dB (A)	47/43/40/37
Dimension of Outline(LXDXH)		mm	710X450X200
Dimension of Carton Box(LXWXH)		mm	1005X565X260
Dimension of Package(LXWXH)		mm	1008X568X275
Net Weight		kg	18.5
Gross Weight		kg	22.5
Liquid pipe		inch	1/4
Gas Pipe(to indoor unit)		inch	3/8

The above data is subject to change without notice. Please refer to the nameplate of the unit.

NOTES:

- The rated cooling capacity data is measured under the following work condition: Indoor Temperature is 27°C DB, 19°CWB. Outdoor Temperature is 35°C DB. The rated heating capacity data is measured under the following work condition: Indoor Temperature is 20°C DB. Outdoor Temperature is 7°C DB, 6°C WB.
- The data will change with the change of products. Refer to those parameters listed on nameplate.
- Noise was tested in semi-silenced room, so the actual noise value will be a little higher for change of ambient.

Working Temperature Range				
	Indoor side state		Outdoor side stae	
	Dry bulb temp. °C	Wet bulb temp. °C	Dry bulb temp. °C	Wet bulb temp. °C
Rated Cooling	27	19	35	24
Max.Cooling	32	23	43	26
Rated Heating	20	15	7	6
Max.Heating	27	-	24	18

Parameter		Unit	Value
Model			GFH(12)CA-D6DNA1C/I
Product Code			CN210N0280
Power Supply	Rated Voltage	V~	220
	Rated Frequency	Hz	60
	Phases		1
Cooling Capacity		W	3500
Heating Capacity		W	4000
Air flow volume		m ³ /h	600/540/420/300
Dehumidifying Volume		L/h	1.4
Fan Type			Centrifugal
Fan Diameter-height		mm	Φ138.6-143
Fan Motor Speed		rpm	Cooling:1160/1030/930/810 Heating:1160/1030/930/810
Fan Motor Power Output		W	20
Fan Motor Power Input		W	75
Motor Full Load Amp(FLA)		A	/
Fan Motor Capacitor		μF	3.5
Evaporator Material			Inner Groove Copper Tube-Aluminum fin
Evaporator Pipe Diameter		mm	Φ5
Evaporator Number of Rows-Fin Pitch		mm	3-1.4
Evaporator Length(L)XHeight(H)XWidth(W)		mm	547X228.6X34.2
Fuse Current		A	5
Sound Pressure Level		dB (A)	36/34/31/27
Sound Power Level		dB (A)	51/49/46/42
Dimension of Outline(LXDXH)		mm	710X450X200
Dimension of Carton Box(LXWXH)		mm	1005X565X260
Dimension of Package(LXWXH)		mm	1008X568X275
Net Weight		kg	19
Gross Weight		kg	23
Liquid pipe		inch	1/4
Gas Pipe(to indoor unit)		inch	3/8

The above data is subject to change without notice. Please refer to the nameplate of the unit.

NOTES:

- The rated cooling capacity data is measured under the following work condition: Indoor Temperature is 27°C DB, 19°CWB. Outdoor Temperature is 35°C DB. The rated heating capacity data is measured under the following work condition: Indoor Temperature is 20°C DB. Outdoor Temperature is 7°C DB, 6°C WB.
- The data will change with the change of products. Refer to those parameters listed on nameplate.
- Noise was tested in semi-silenced room, so the actual noise value will be a little higher for change of ambient.

Working Temperature Range				
	Indoor side state		Outdoor side stae	
	Dry bulb temp. °C	Wet bulb temp. °C	Dry bulb temp. °C	Wet bulb temp. °C
Rated Cooling	27	19	35	24
Max.Cooling	32	23	43	26
Rated Heating	20	15	7	6
Max.Heating	27	-	24	18

Parameter		Unit	Value
Model			GFH(18)CB-D6DNA1C/I
Product Code			CN210N0290
Power Supply	Rated Voltage	V~	220
	Rated Frequency	Hz	60
	Phases		1
Cooling Capacity		W	5000
Heating Capacity		W	5500
Air flow volume		m ³ /h	800/720/610/420
Dehumidifying Volume		L/h	1.8
Fan Type			Centrifugal
Fan Diameter-height		mm	Φ138.6-143
Fan Motor Speed		rpm	Cooling:1060/920/810/700 Heating:1060/920/810/700
Fan Motor Power Output		W	20
Fan Motor Power Input		W	80
Motor Full Load Amp(FLA)		A	/
Fan Motor Capacitor		μF	3.5
Evaporator Material			Inner Groove Copper Tube-Aluminum fin
Evaporator Pipe Diameter		mm	Φ7
Evaporator Number of Rows-Fin Pitch		mm	3-1.4
Evaporator Length(L)XHeight(H)XWidth(W)		mm	847X228.6X38.1
Fuse Current		A	5
Sound Pressure Level		dB (A)	36/31/28/25
Sound Power Level		dB (A)	51/46/43/40
Dimension of Outline(LXDXH)		mm	1010X450X200
Dimension of Carton Box(LXWXH)		mm	1305X565X260
Dimension of Package(LXWXH)		mm	1308X568X275
Net Weight		kg	25
Gross Weight		kg	30
Liquid pipe		inch	1/4
Gas Pipe(to indoor unit)		inch	1/2

The above data is subject to change without notice. Please refer to the nameplate of the unit.

NOTES:

- The rated cooling capacity data is measured under the following work condition: Indoor Temperature is 27°C DB, 19°CWB. Outdoor Temperature is 35°C DB. The rated heating capacity data is measured under the following work condition: Indoor Temperature is 20°C DB. Outdoor Temperature is 7°C DB, 6°C WB.
- The data will change with the change of products. Refer to those parameters listed on nameplate.
- Noise was tested in semi-silenced room, so the actual noise value will be a little higher for change of ambient.

Working Temperature Range				
	Indoor side state		Outdoor side stae	
	Dry bulb temp. °C	Wet bulb temp. °C	Dry bulb temp. °C	Wet bulb temp. °C
Rated Cooling	27	19	35	24
Max.Cooling	32	23	43	26
Rated Heating	20	15	7	6
Max.Heating	27	-	24	18

3. Outline Dimension Diagram

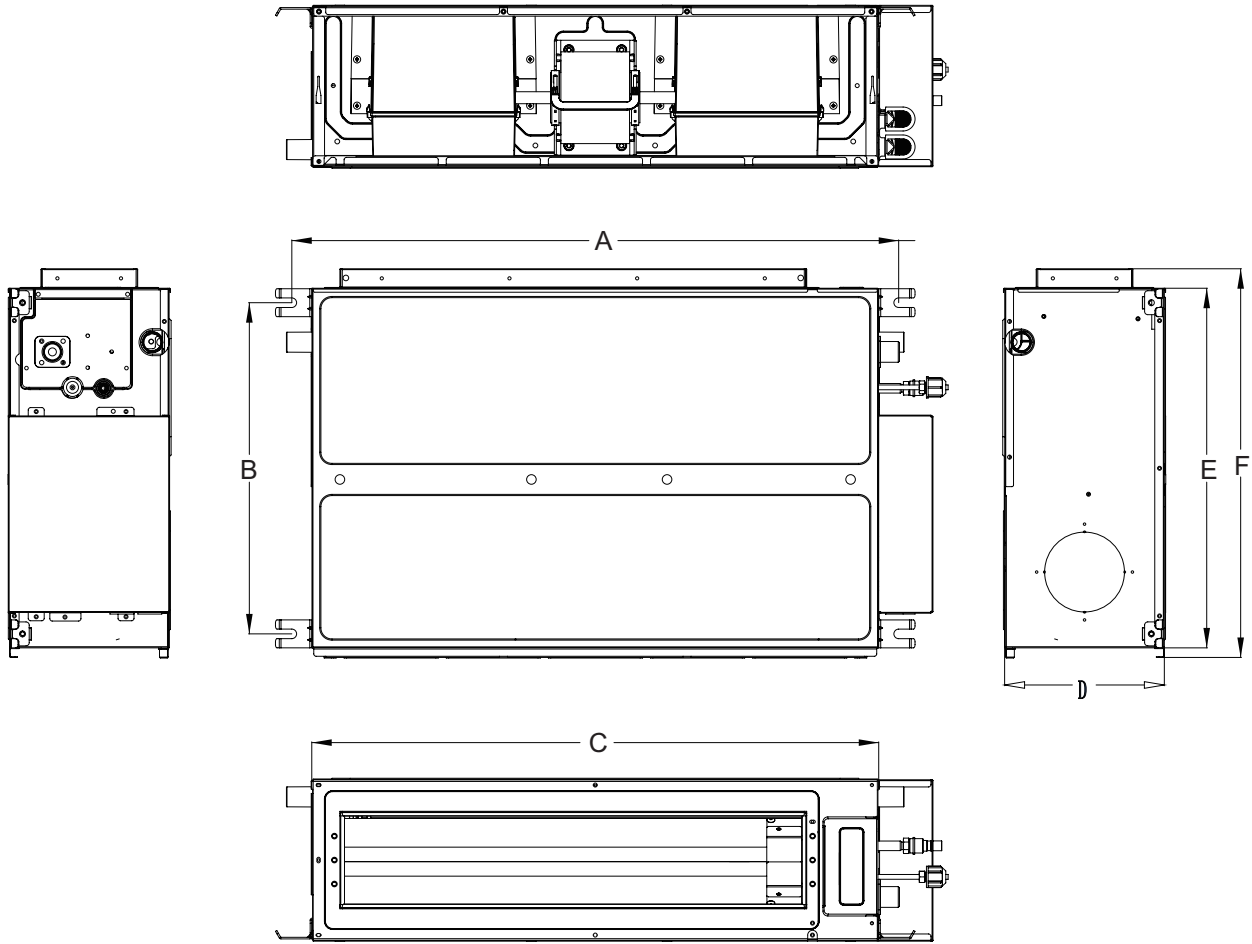

Unit: mm

Model	A	B	C	D	E	F
09K / 12K	760	415	710	200	450	487
18K	1060	415	1010	200	450	487

4. Refrigerant System Diagram

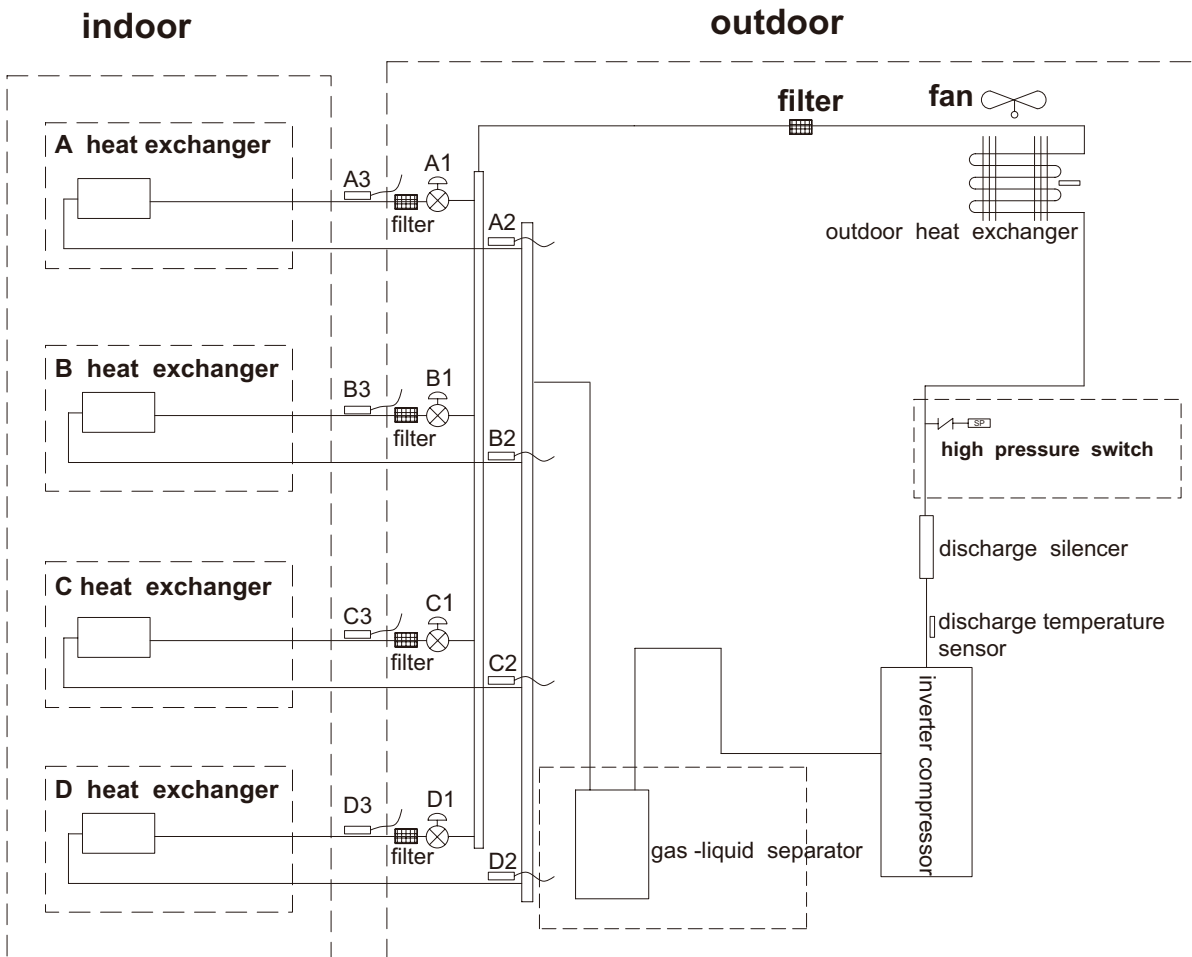

A1:A-unit electronic expansion valve B1:B-unit electronic expansion valve
C1:C-unit electronic expansion valve D1:D-unit electronic expansion valve
A2:A-unit gas pipe temperature sensor B2:B-unit gas pipe temperature sensor
C2:C-unit gas pipe temperature sensor D2:D-unit gas pipe temperature sensor
A3:A-unit liquid pipe temperature sensor B3:B-unit liquid pipe temperature sensor
C3:C-unit liquid pipe temperature sensor D3:D-unit liquid pipe temperature sensor

5. Electrical Part

5.1 Wiring Diagram

• Instruction

Symbol	Symbol Color	Symbol	Symbol Color	Symbol	Name
WH	White	GN	Green	CAP	Jumper cap
YE	Yellow	BN	Brown	COMP	Compressor
RD	Red	BU	Blue		Grounding wire
YEGN	Yellow/Green	BK	Black	/	/
VT	Violet	OG	Orange	/	/

Note: Jumper cap is used to determine fan speed and the swing angle of horizontal lever for this model.

GFH(09)CA-D6DNA1C/I GFH(12)CA-D6DNA1C/I GFH(18)CB-D6DNA1C/I

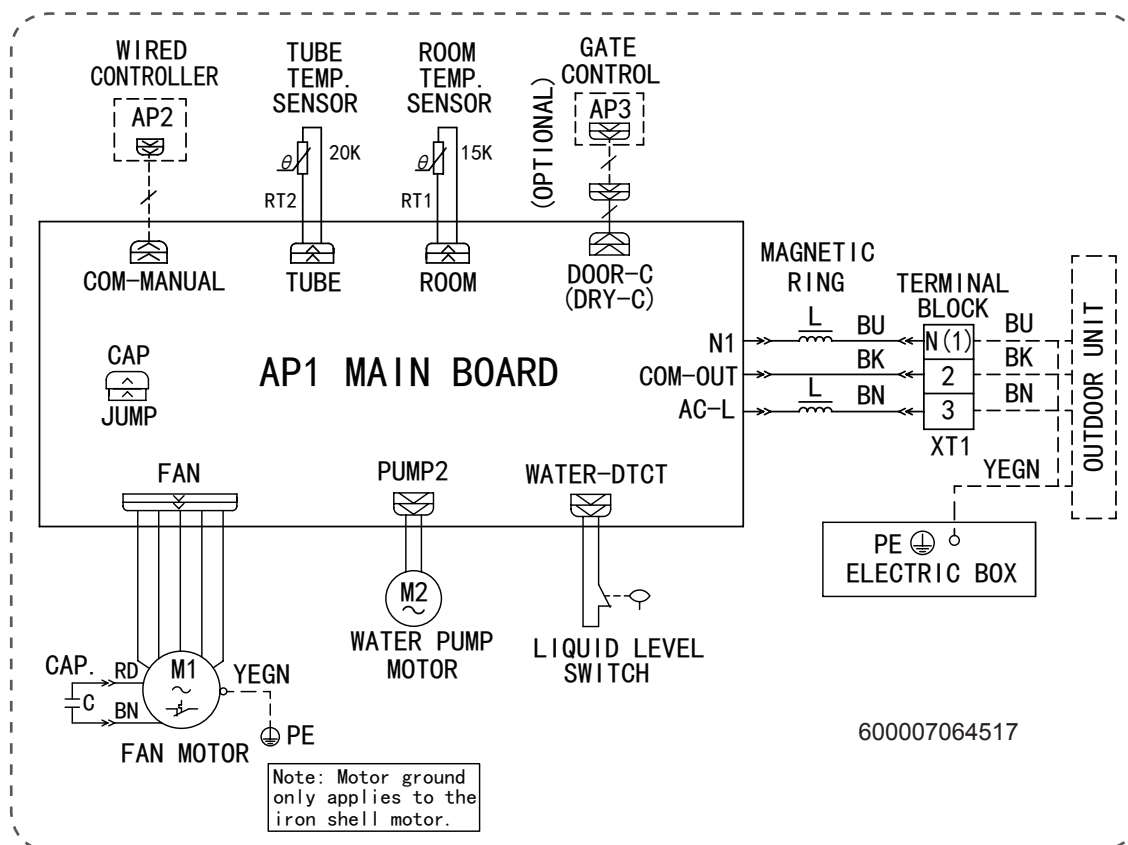

These wiring diagrams are subject to change without notice; please refer to the one supplied with the unit.

6. Function and Control

6.1 Wired Controller for XE73-44/E

1 Symbols on LCD

1.1 Outside View of the Wired Controller

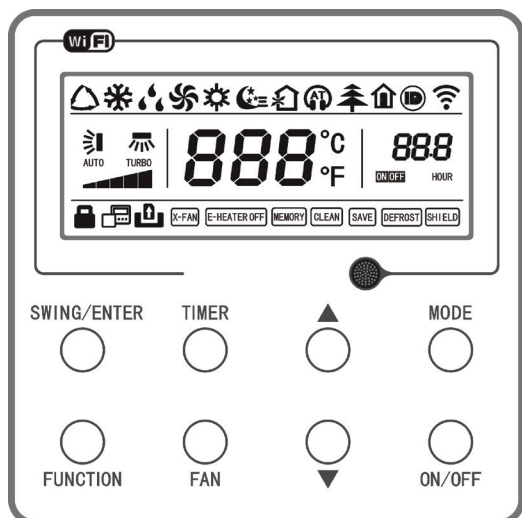

Fig.1 Outside View of the Wired Controller

1.2 LCD of the Wired Controller

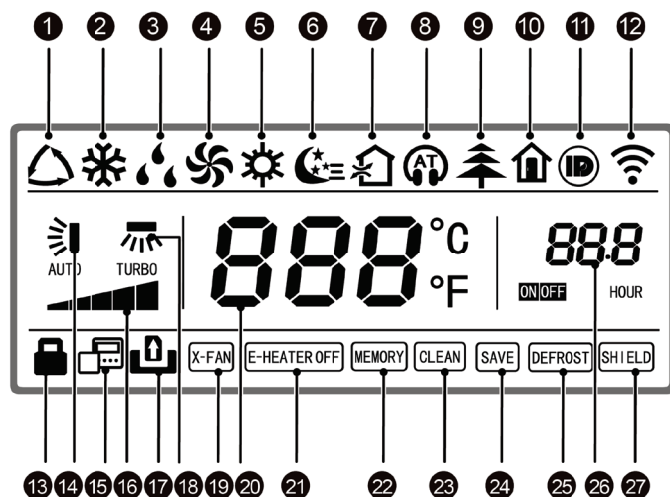

Fig.2 LCD of the Wired Controller

Table 1

No.	Display	Instruction of Display	No.	Display	Instruction of Display
1	Auto	Automatic mode (under auto mode, the indoor unit will select its operating mode according to the variation of room temperature)	15	Slave wired controller	Icon of slave wired controller, it will display when slave wired controller is set (this function is unavailable for this unit)
2	Cool	Cooling mode	16	Fan speed	The fan speed set currently (including auto, low, medium low, medium, medium high, high, and turbo)
3	Dry	Dry mode	17	No card	No card in gate control system
4	Fan	Fan mode	18	Left & right swing	Display when left and right swing function is set
5	Heat	Heating mode	19	X-fan	Display when X-fan function is set
6	Sleep	Display when sleep function is set	20	Temperature	It will display the setting temperature
7	Fresh air	Display when fresh air function is set	21	E-heater	On/off switch of auxiliary heating
8	Quiet	Display when quiet function is set	22	Memory	Memory status (After power failure and reenergizing the unit, it will resume to ON/OFF status of unit before the power failure)
9	Health	Display when health function is set	23	Clean	Filter washing reminder (this function is unavailable for this unit)
10	Absent	Display when absent function is set	24	Save	Display when energy-saving function is set
11	I-DEMAND	Display when I-DEMAND function is set	25	Defrost	Defrosting status
12	WiFi	Display when WiFi function is set	26	Defrost	Display when timer status is set
13	Child-lock	Child-lock status, display when child-lock function is set	27	Shield	Shielding status
14	Up & down swing	Display when up and down swing function is set			

2 Buttons

2.1 Buttons on the Wired Controller

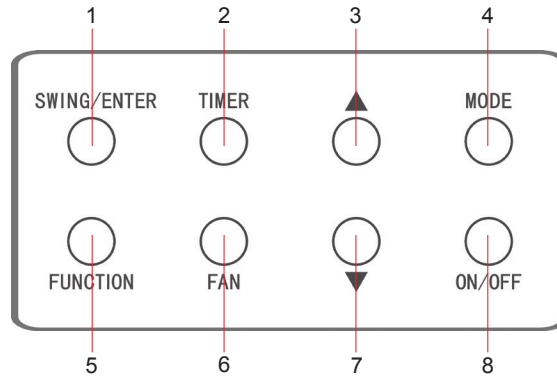

Fig. 3 Buttons on the Wired Controller

2.2 Function of the Buttons

Table 2

No.	Name	Function
1	SWING/ENTER	1. Function selection and cancellation. 2. Setting of the up and down swing function.
3	▲	1. Running temperature setting of the indoor unit, range: 16~30°C(61~86°F). 2. Timer setting, range: 0.5-24 hr.
7	▼	
6	FAN	Setting of the auto/low/medium low/medium/medium high/high fan speed.
4	MODE	Setting of the Cooling/Heating/Fan/Dry/Auto mode of the indoor unit.
5	FUNCTION	Switchover among the functions of Turbo/WiFi/E-heater/X-fan etc..
2	TIMER	TIMER
8	ON/OFF	Turn on/off the indoor unit.
3+4	▲+MODE	Press them for 5s under off state of the unit to Enter/Cancel the Memory function(If memory is set, indoor unit after power failure and then power recovery will resume the original setting state. If not, the indoor unit is defaulted to be off after power recovery. Memory off is default before delivery.).
6+7	FAN+▼	By pressing them at the same time under off state of the unit, ❄ will be displayed on the wired controller for the cooling only unit, while ❄ will be displayed on the wired controller for the cooling and heating unit.
3+7	▲+▼	Upon startup of the unit without malfunction or under off state of the unit, press them at the same time for 5s to enter the lock state, in which case, any other buttons won't respond the press. Repress them for 5 seconds to quit this state.
4+7	MODE+▼	Under OFF state, the Celsius and Fahrenheit scales can be switched by pressing "MODE" and "▼" for 5s.
2+5	TIMER+FUNCTION	Under OFF state, it is available to go to the commissioning status by pressing "FUNCTION" and "TIMER" for five seconds, and let "00" displayed on the temperature display area by pressing "MODE", then adjust the options which is shown on the timer area by pressing "▲" and "▼". There are totally four options, as follows: 1. Indoor ambient temperature is sensed by the return air temperature sensor (01 displayed on the timer area). 2. Indoor ambient temperature is sensed by the wired controller (02 displayed on the timer area). 3. The return air temperature sensor is selected under the cooling, dry, or fan mode; while the wired controller temperature sensor is selected under the heating or auto mode. (03 is displayed on the timer area). 4. The wired controller temperature sensor is selected under the cooling, dry, or fan mode; while the return air temperature sensor is selected under the heating mode. (04 is displayed on the timer display area).
2+5	TIMER+FUNCTION	Under OFF state, it is available to go to the commissioning status by pressing "FUNCTION" and "TIMER" for five seconds. Press "MODE" button to until "01" icon is shown at the temperature display area. The setting status will be shown at timer area. Press "▲" and "▼" button to adjust and two options are available: 1. Three low levels (01); 2. Three high levels (02).
5+6	FUNCTION+FAN	Reset the WiFi function: Under off status, press "FUNCTION" + "FAN" combination buttons on its wired controller for 5s. Once "C" is displayed, this indicates that reset was successful.

3 Operation Instructions

3.1 ON/OFF

Press ON/OFF to turn on the unit and turn it off by another press.

NOTE: The state shown in Fig.4 indicates the "OFF" state of the unit after power on. The state shown in Fig.5 indicates the "ON" state of the unit after power on.

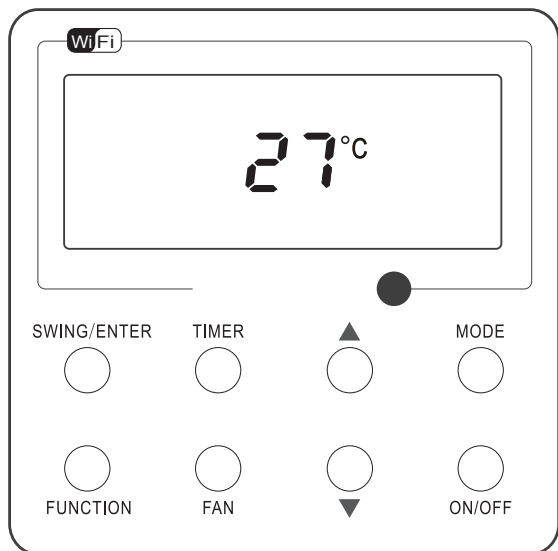

Fig. 4 "OFF" State

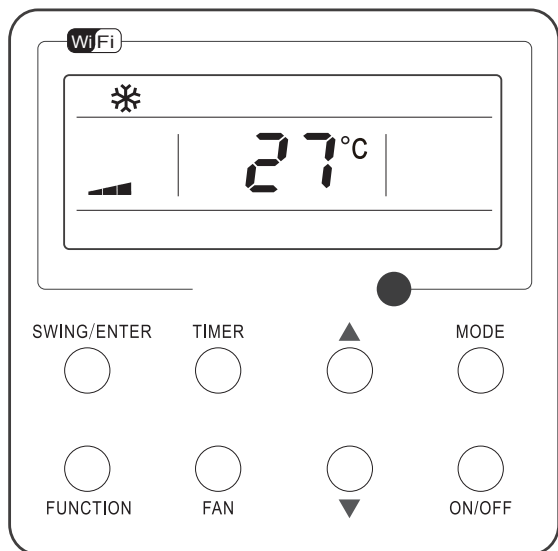
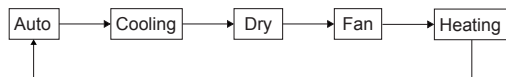

Fig. 5 "ON" State

3.2 Mode Setting

Under the "ON" state of the unit, press MODE to switch the operation modes as the following sequence: Auto-Cooling-Dry-Fan-Heating.



3.3 Temperature Setting

Press ▲ or ▼ to increase/decrease the preset temperature. If press either of them continuously, the temperature will be increased or decreased by 1°C(1°F) every 0.5s, as shown in Fig.6.

In the Cooling, Dry, Fan or Heating mode, the temperature setting range is 16°C~30°C(61°F~86°F).

In the Auto mode, the setting temperature is unadjustable.

NOTE: If the wired controller receives the signals of remote controller, the wired controller can analyze the set temperature adjustment function of automatic mode of the remote controller, but it needs to be used with an indoor unit with the set temperature adjustment function of automatic mode.

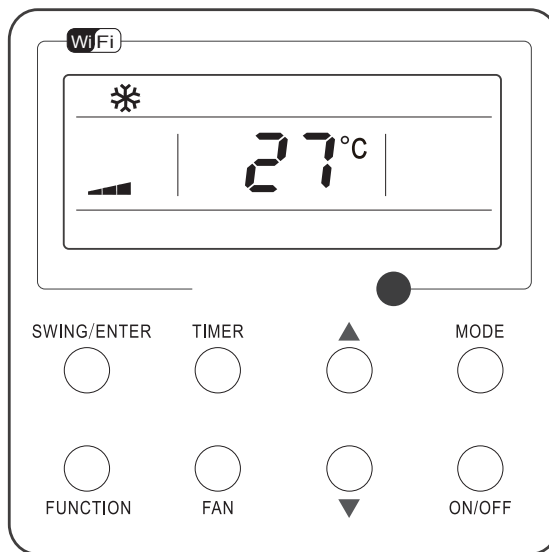

Fig. 6

3.4 Fan Setting

Under the "ON" State of the unit, press Fan and then fan speed of the indoor unit will change circularly as shown in Fig.7.

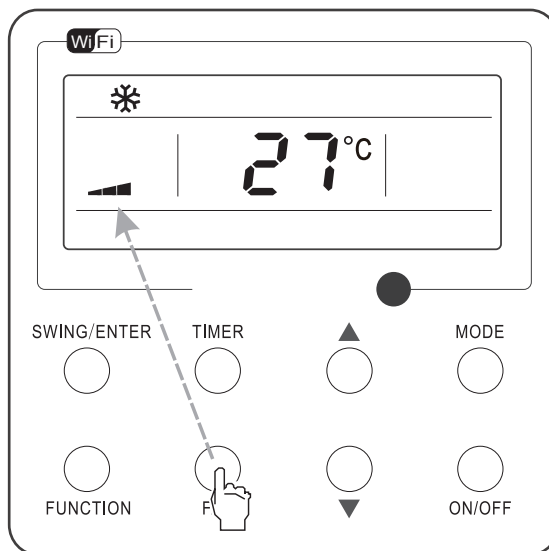
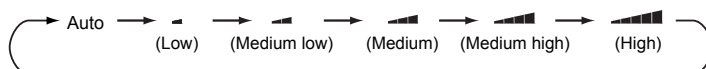



Fig. 7

3.7 Left & Right Swing Setting

- Swing On: Press FUNCTION under on state of the unit to activate the swing function. In this case,  will blink. After that, press SWING/ENTER to make a confirmation.
- Swing Off: When the Swing function is on, press FUNCTION to enter the Swing setting interface, with  blinking. After that, press SWING/ENTER to cancel this function.

Swing setting is shown as Fig.9.

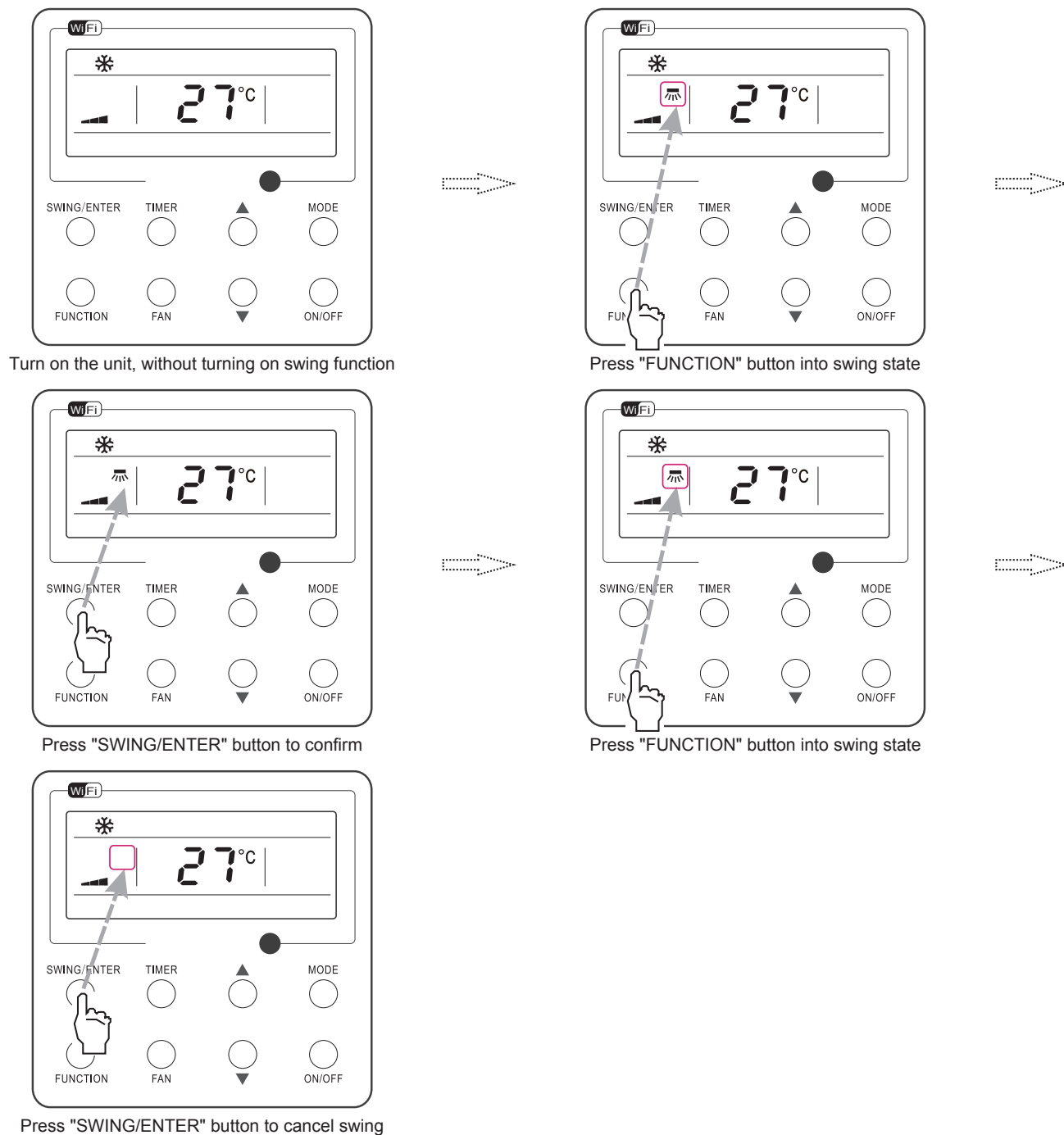



Fig. 9 Swing Setting

- NOTE:**
1. Sleep, Turbo or X-fan setting is the same as the Swing setting.
 2. After the setting has been done, it has to press the key "SWING/ENTER" to back to the setting status or quit automatically five seconds later.

3.8 Fresh Air Valve Function Setting

- Turn on fresh air valve function:

Under unit on status, press FUNCTION button on the panel to select "Fresh air valve" function option. When  icon flashes, it enters fresh air valve setting mode. Previous temperature display position will display the level of fresh air valve. Press ▲ or ▼ button to adjust the level of fresh air valve within the range from 1 to 10. Then press SWING/ENTER button to activate this function.

- Turn off fresh air valve function:

If fresh air valve function has been set, press FUNCTION button on the panel to select "Fresh air valve" function option. When icon  flashes, if you press SWING/ENTER button without pressing ▲ or ▼ button, fresh air valve function will be canceled; if you press SWING/ENTER button after pressing ▲ or ▼ button, fresh air valve function will be activated.

NOTE:

1. If you press panel button to set fresh air valve function on, ventilation (ventilation 1) function will be activated too; if you press panel button to set fresh air valve function off, ventilation function will be canceled too.
2. This function is invalid when working with the model with two-way ventilation system.

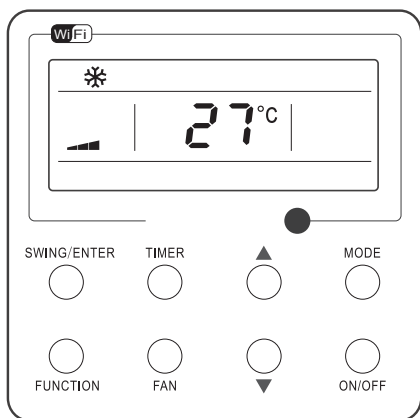

Turn on the unit with the "Fresh Air" function deactivated

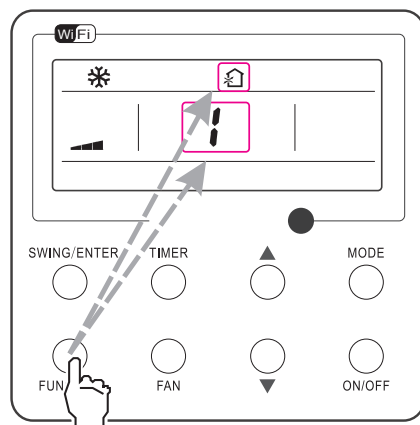

Press "FUNCTION" button to select the "Fresh Air" function option

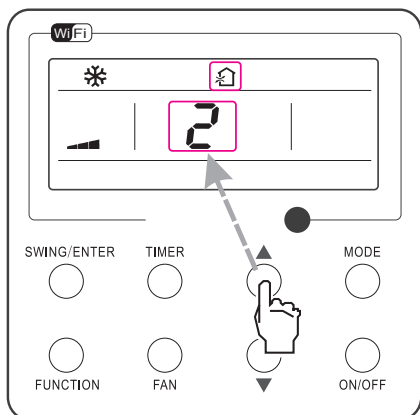

Press ▲ or ▼ to adjust the "Fresh Air" type

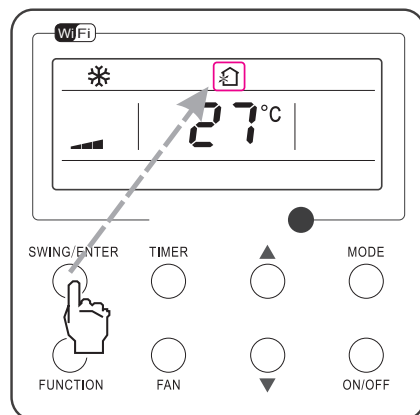

Press "SWING/ENTER" button to activate the "Fresh Air" function

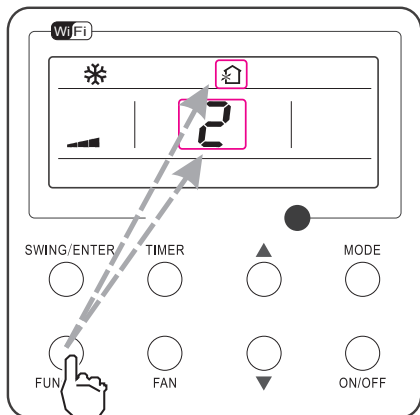

Press "FUNCTION" button to select the "Fresh Air" function option

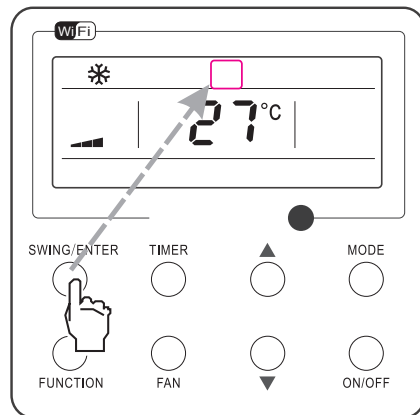

Press "SWING/ENTER" button to deactivate the "Fresh Air" function

Fig. 10 Fresh Air Valve Function Setting

3.9 Sleep Setting

- Sleep on: Press FUNCTION under on state of the unit till the unit enters the Sleep setting interface. Press SWING/ENTER to confirm the setting.
- Sleep off: When the Sleep function is activated, press FUNCTION to enter the Sleep setting interface. After that, press SWING/ENTER to can this function.

Sleep setting is shown as Fig.11.

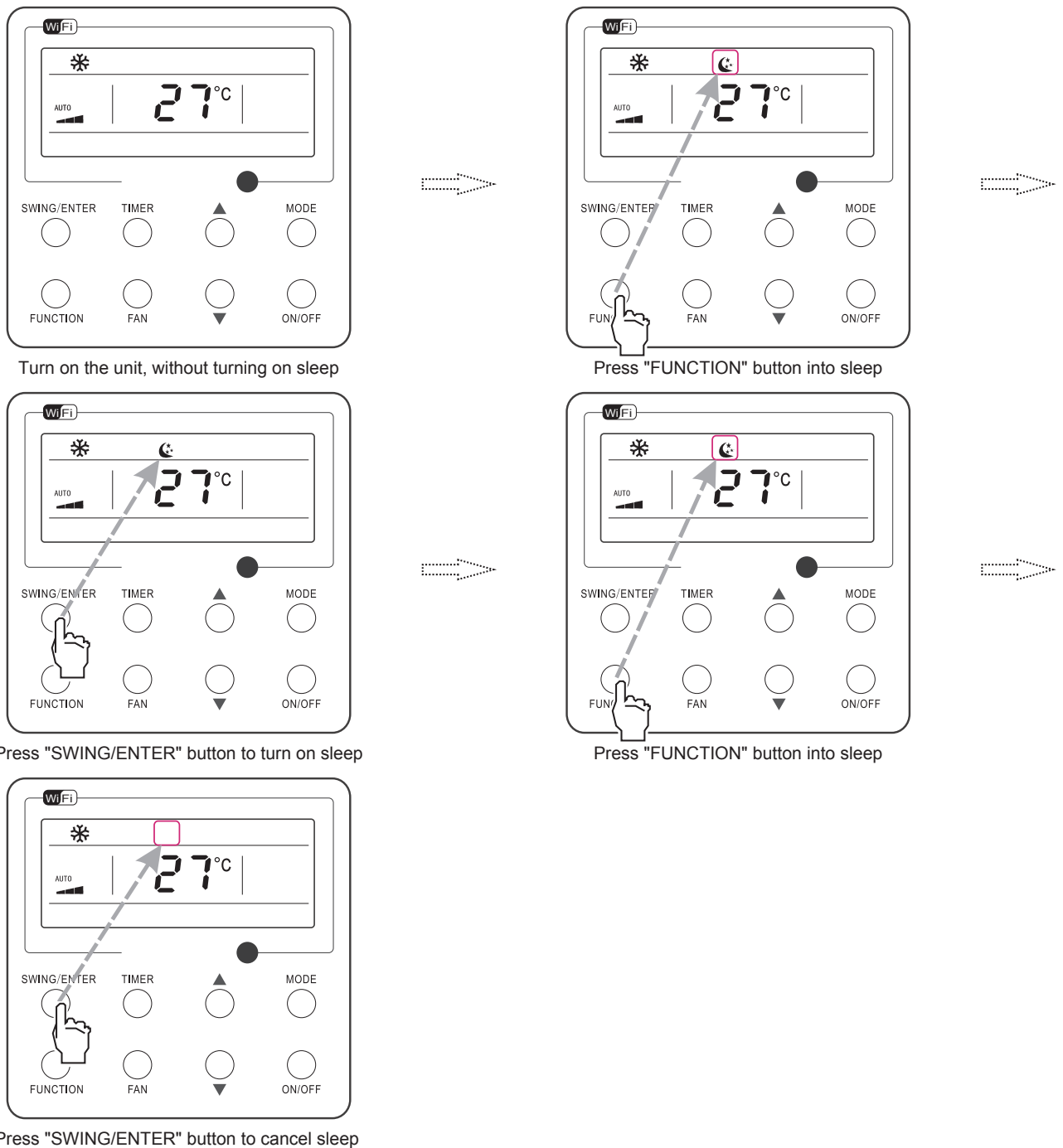

Fig. 11 Sleep Setting

3.10 Turbo Setting

Turbo function: The unit at the high fan speed can realize quick cooling or heating so that the room temperature can quickly approach the setting value.

In the Cooling or Heating mode, press FUNCTION till the unit enters the Turbo setting interface and then press SWING/ENTER to confirm the setting.

When the Turbo function is activated, press FUNCTION to enter the Turbo setting interface and then press SWING/ENTER to cancel this function.

Turbo function setting is as shown in Fig.12.

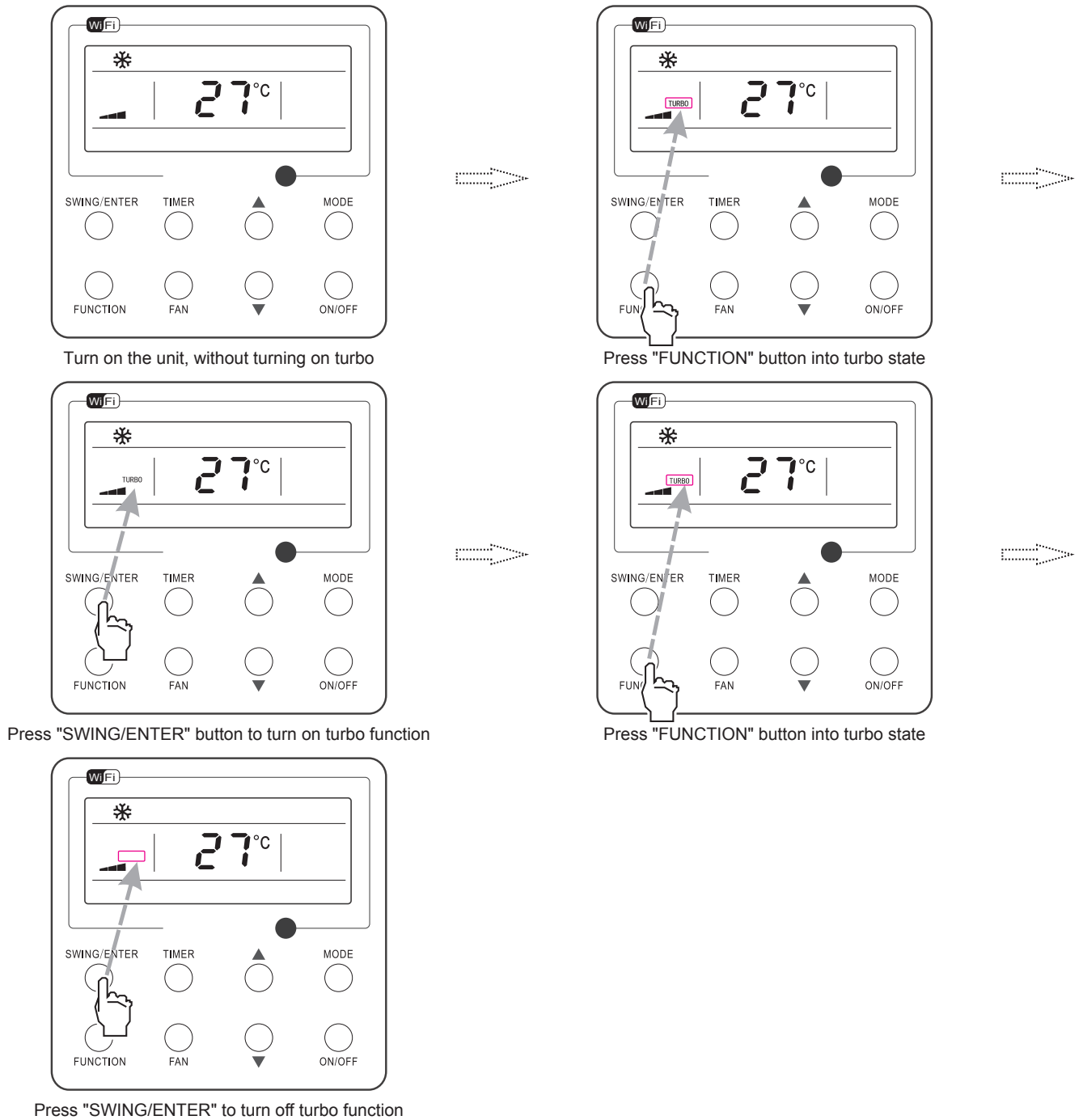

Fig. 12 Turbo Setting

3.11 Energy Saving Function Setting

- Turn on energy saving function:

1. Energy Saving Setting for Cooling

When the unit runs under the COOL or DRY mode, press FUNCTION button to select "SAVE" function option, with "SAVE" flashing, and then press ▲ or ▼ to adjust the lower limit, after that, press the SWING/ENTER button to activate this function.

2. Energy Saving Setting for Heating

When the unit runs under the HEAT mode, press FUNCTION button to select "SAVE" function option, with "SAVE" flashing, and then press ▲ or ▼ to adjust the upper limit, after that, press SWING/ENTER button to activate this function.

NOTE: Under energy saving setting mode, press "MODE" button to switch the energy saving setting for COOL or HEAT mode.

- Cancel energy saving function:

If energy saving function has been set, press FUNCTION button on the panel to select "SAVE" function option. When  icon flashes, if you press SWING/ENTER button without pressing ▲ or ▼ button, energy saving function will be canceled; if you press SWING/ENTER button after pressing ▲ or ▼ button, energy saving function will be activated.

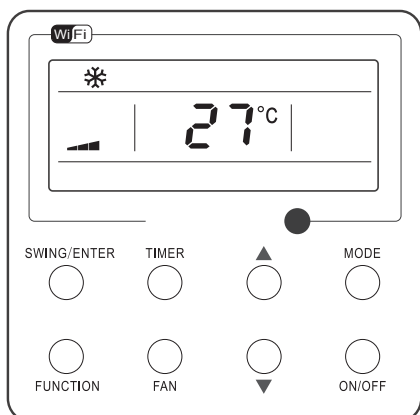

Turn on the unit with the "SAVE" function deactivated

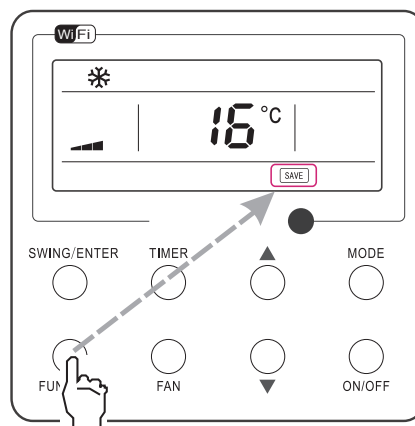

Press "FUNCTION" button to select the "SAVE" function option

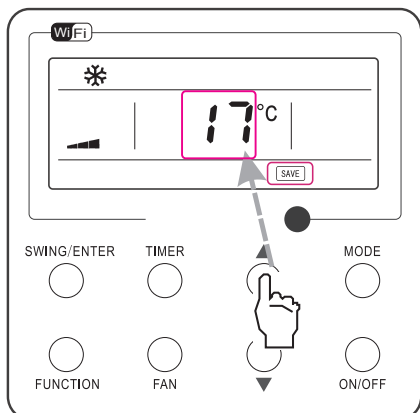

Press ▲ or ▼ to adjust the lower limit

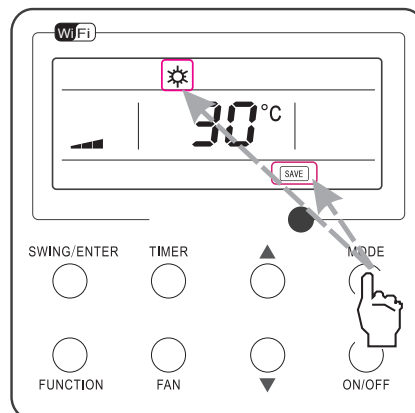

Press "MODE" button to switch to the "SAVE" setting for heating

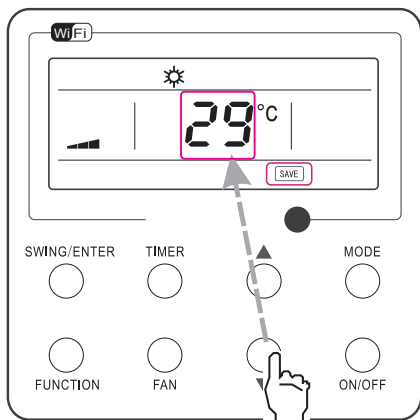

Press ▲ or ▼ to adjust the upper limit

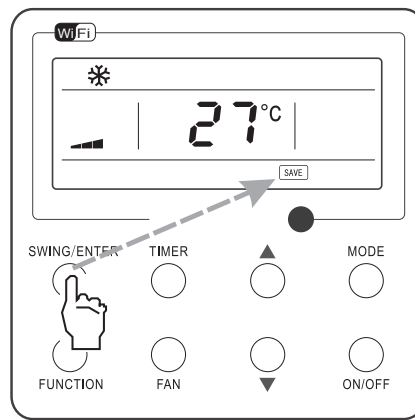

Press "SWING/ENTER" button to activate the "SAVE" function

Fig. 13 Energy Saving Function Setting

3.12 E-heater Setting

E-heater (auxiliary electric heating function): In the Heating mode, E-heater is allowed to be turned on for improvement of efficiency.

Once the wired controller or the remote controller enters the Heating mode, this function will be turned on automatically.

Press FUNCTION in the Heating mode to enter the E-heater setting interface and then press SWING/ENTER to cancel this function.

Press FUNCTION to enter the E-heater setting interface, if the E-heater function is not activated, and then press SWING/ENTER to turn it on.

The setting of this function is shown as Fig.14 below:

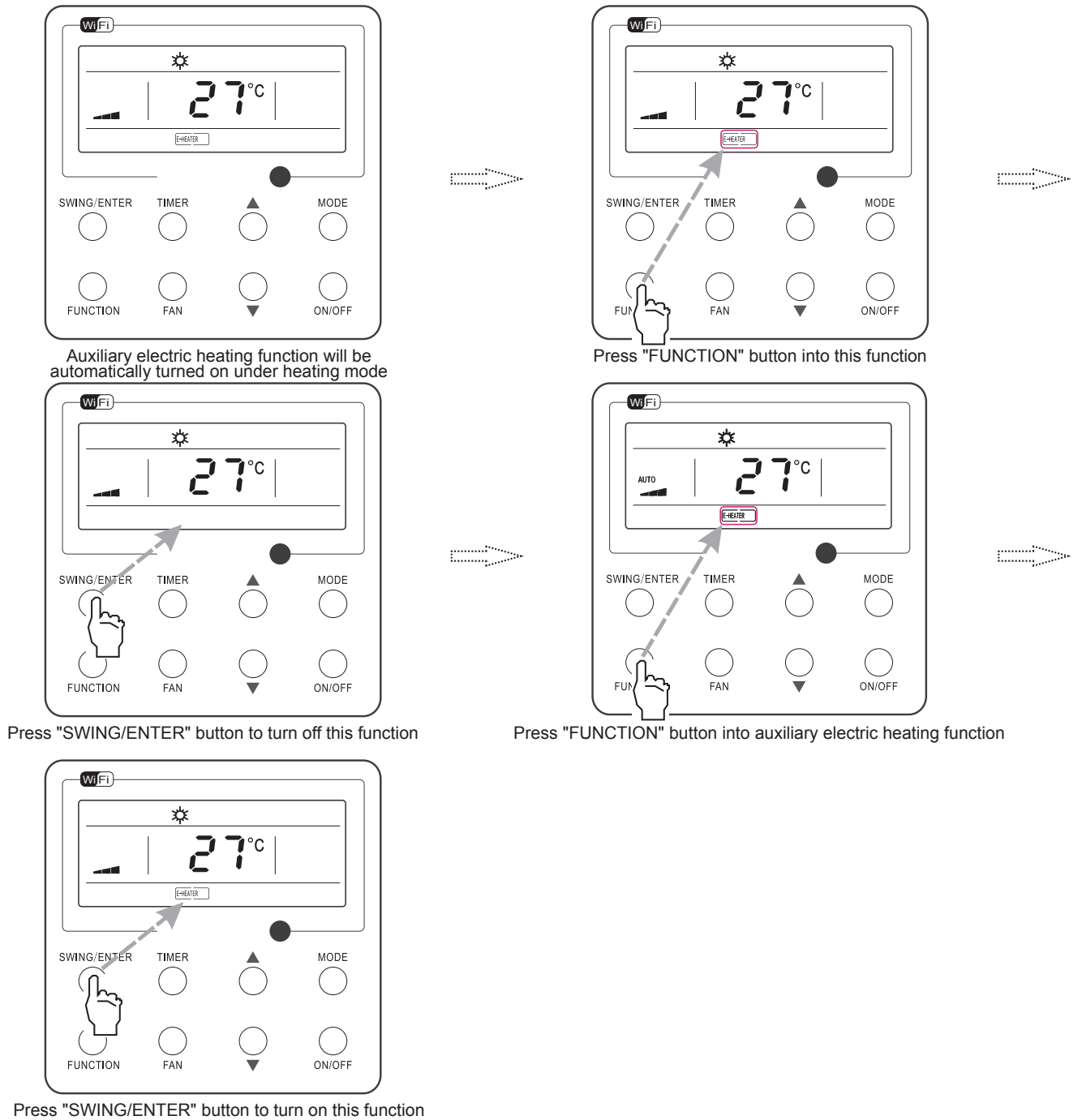

Fig. 14 E-heater Setting

3.13 X-fan Setting

X-fan function: After the unit is turned off, the water in evaporator of indoor unit will be automatically evaporated to avoid mildew.

In the Cooling or Dry mode, press FUNCTION till the unit enters the X-fan setting interface and then press SWING/ENTER to activate this function.

When the X-fan function is activated, press FUNCTION to the X-fan setting interface and then press SWING/ENTER to cancel this function.

X-fan function setting is as shown in Fig.15.

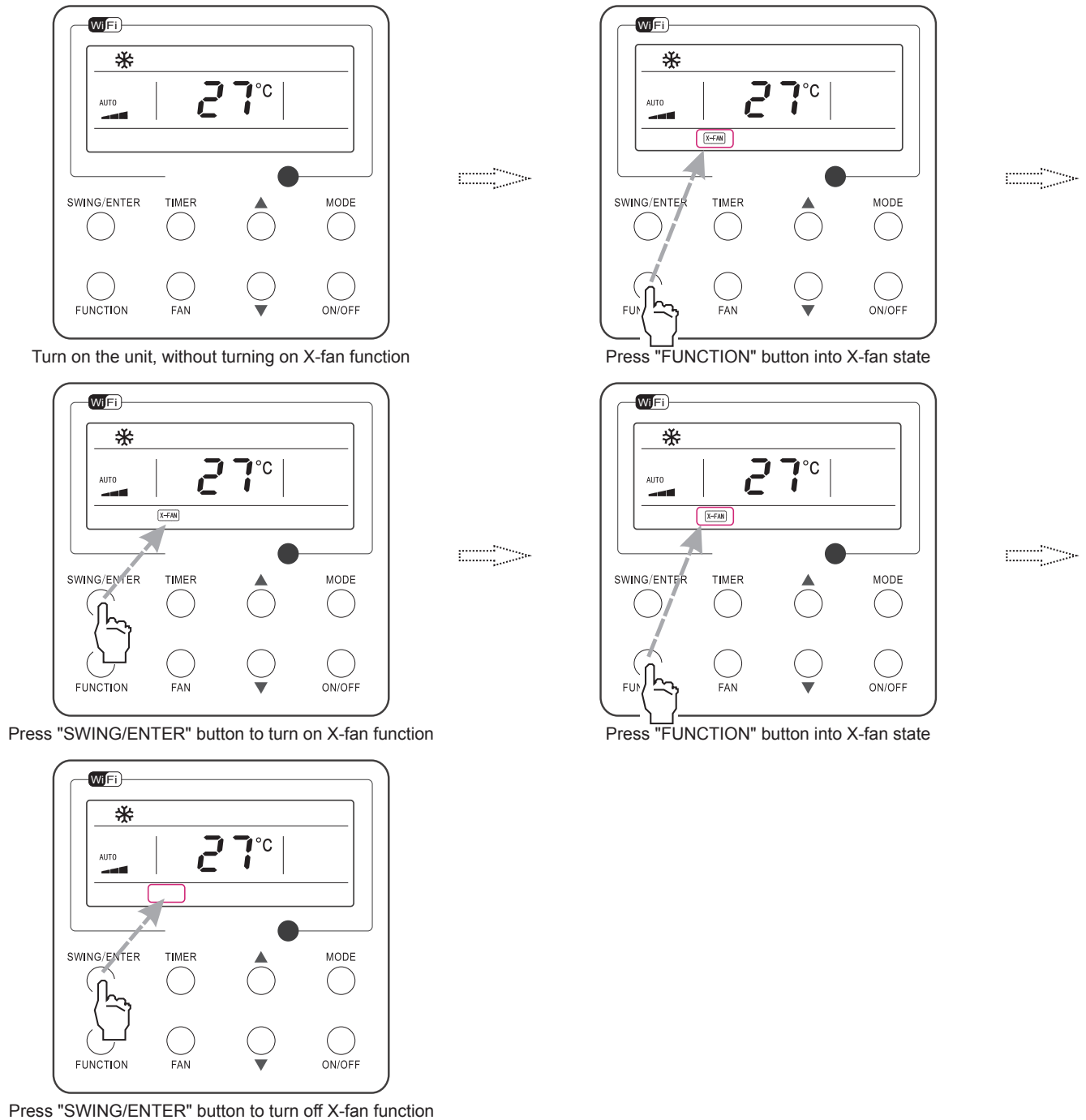

Fig. 15 X-fan Setting

- NOTE:**
- When the X-fan function is activated, if turning off the unit by pressing ON/OFF or by the remote controller, the indoor fan will run at the low fan speed for 2 minutes, with "X-FAN" displayed on the LCD. While, if the X-fan function is deactivated, the indoor fan will be turned off directly.
 - X-fan function is unavailable in the Fan or Heating mode.

3.14 Quiet Function Setting

- Turn on quiet function:

Under unit on status, press FUNCTION button on the panel to select "Quiet" function option. When "Quiet" or "Auto quiet" flashes, it enters quiet function setting mode. Press ▲ or ▼ button to switch between "Quiet" and "Auto quiet" function. Then press SWING/ENTER button to activate this function.

- Cancel quiet function:

If quiet function has been set, press FUNCTION button on the panel to select "Quiet" function option. When "Quiet" or "Auto quiet" flashes, if you press SWING/ENTER button without pressing ▲ or ▼ button, quiet function will be canceled; if you press SWING/ENTER button after pressing ▲ or ▼ button, quiet function will be activated.

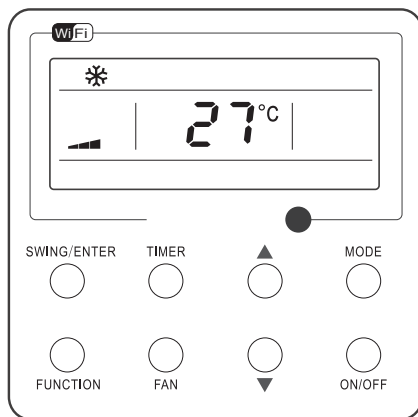

Turn on the unit with the "Quiet" function deactivated

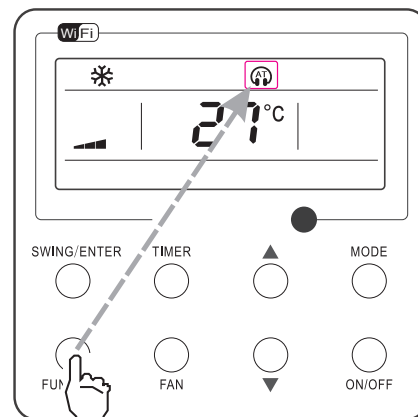

Press "FUNCTION" button to select the "Quiet" function option

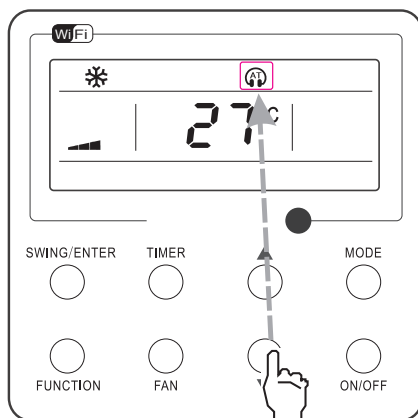

Press ▲ or ▼ to select the desired type, "QUIET" or "AUTO QUIET"

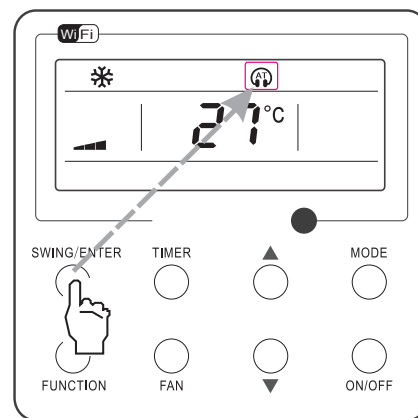

Press "SWING/ENTER" button to activate this function

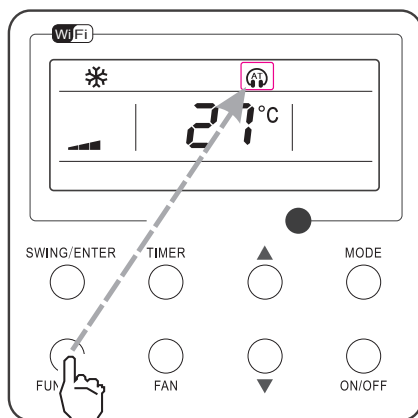

Press the Function button to select the "Quiet" function option

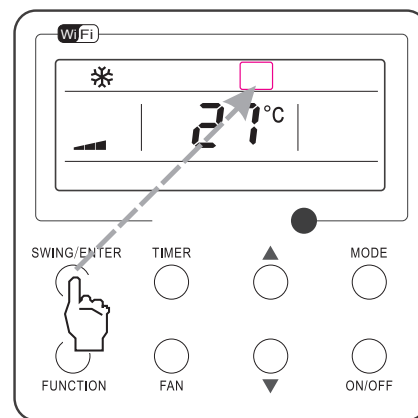

Press "SWING/ENTER" button to deactivate this function

Fig. 16 Setting of Quiet Function

3.15 Health Setting

- Health on: Press FUNCTION under on state of the unit till the unit enters the Health setting interface. Press SWING/ENTER to confirm the setting.
- Health off: When the Health function is activated, press FUNCTION to enter the Health setting interface. After that, press SWING/ENTER to cancel this function.

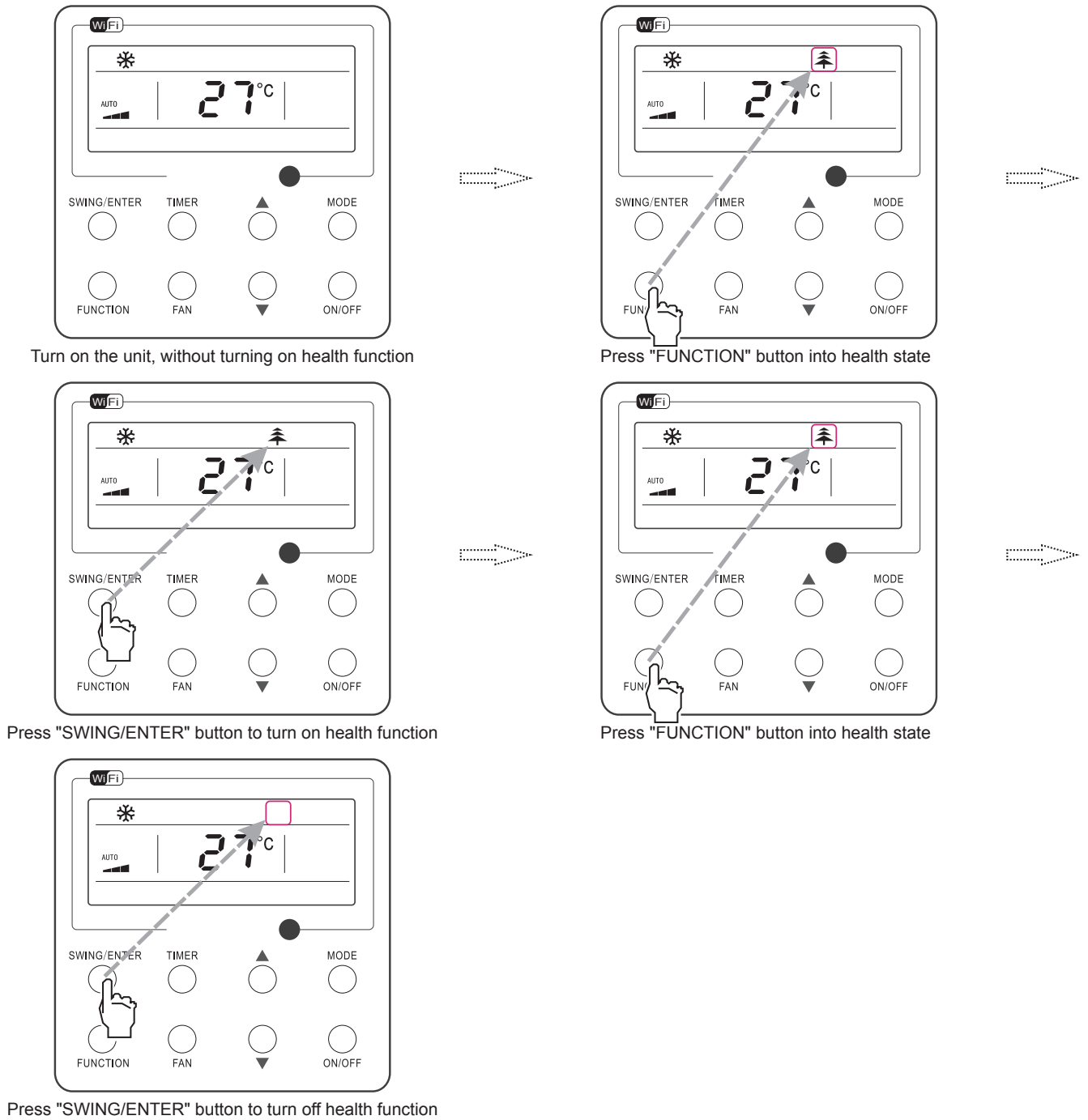

Fig. 17 Health Setting

3.16 Absent Setting

- Absent on: Press FUNCTION under on state of the unit till the unit enters the Absent setting interface. Press SWING/ENTER to confirm the setting.
- Absent off: When the Absent function is activated, press FUNCTION to enter the Absent setting interface. After that, press SWING/ENTER to cancel this function.

- NOTE:**
1. This function is only available in heating mode.
 2. When this function has been set, set temperature is displayed in 8°C(46°F). In this case, temperature setting and fan speed setting are shielded.
 3. This function will be cancelled when switching modes.
 4. This function and sleep function cannot be on simultaneously. If Absent function is set firstly and then sleep/quiet function is set, Absent function will be cancelled while sleep function will be valid, and vice versa.

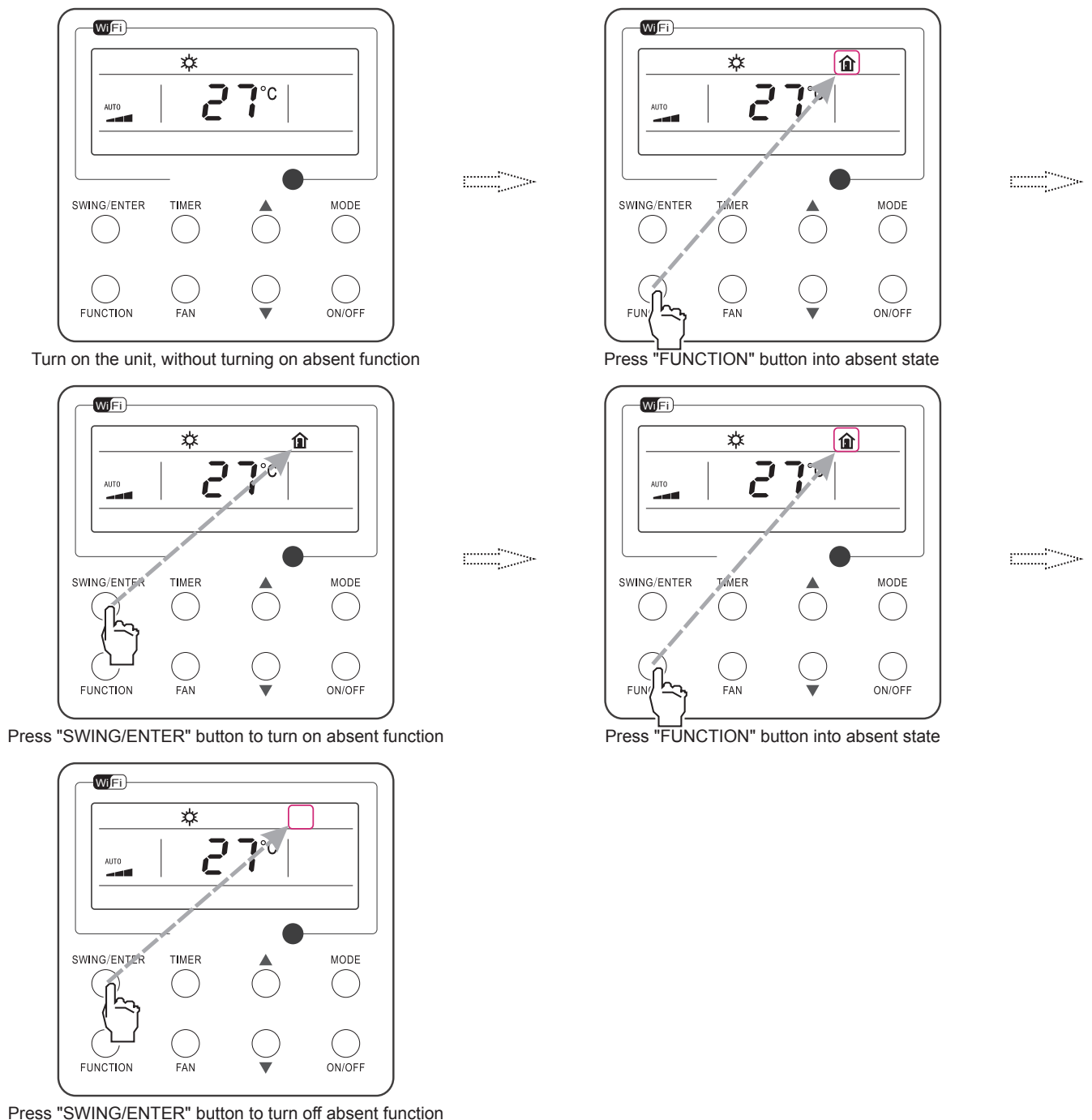

Fig. 18 Absent Setting

3.17 I-Demand Setting

- I-Demand on: Press FUNCTION under on state of the unit till the unit enters the I-Demand setting interface. Press SWING/ENTER to confirm the setting.
- I-Demand off: When the I-Demand function is activated, press FUNCTION to enter the I-Demand setting interface. After that, press SWING/ENTER to cancel this function.

- NOTE:**
1. This function is only available in cooling mode.
 2. When this function has been set, set temperature is displayed in SE. In this case, temperature setting and fan speed setting are shielded.
 3. This function will be cancelled when switching modes.
 4. This function and sleep function cannot be on simultaneously. If I-demand function is set firstly and then sleep/quiet function is set, I-demand function will be cancelled while sleep function will be valid, and vice versa.

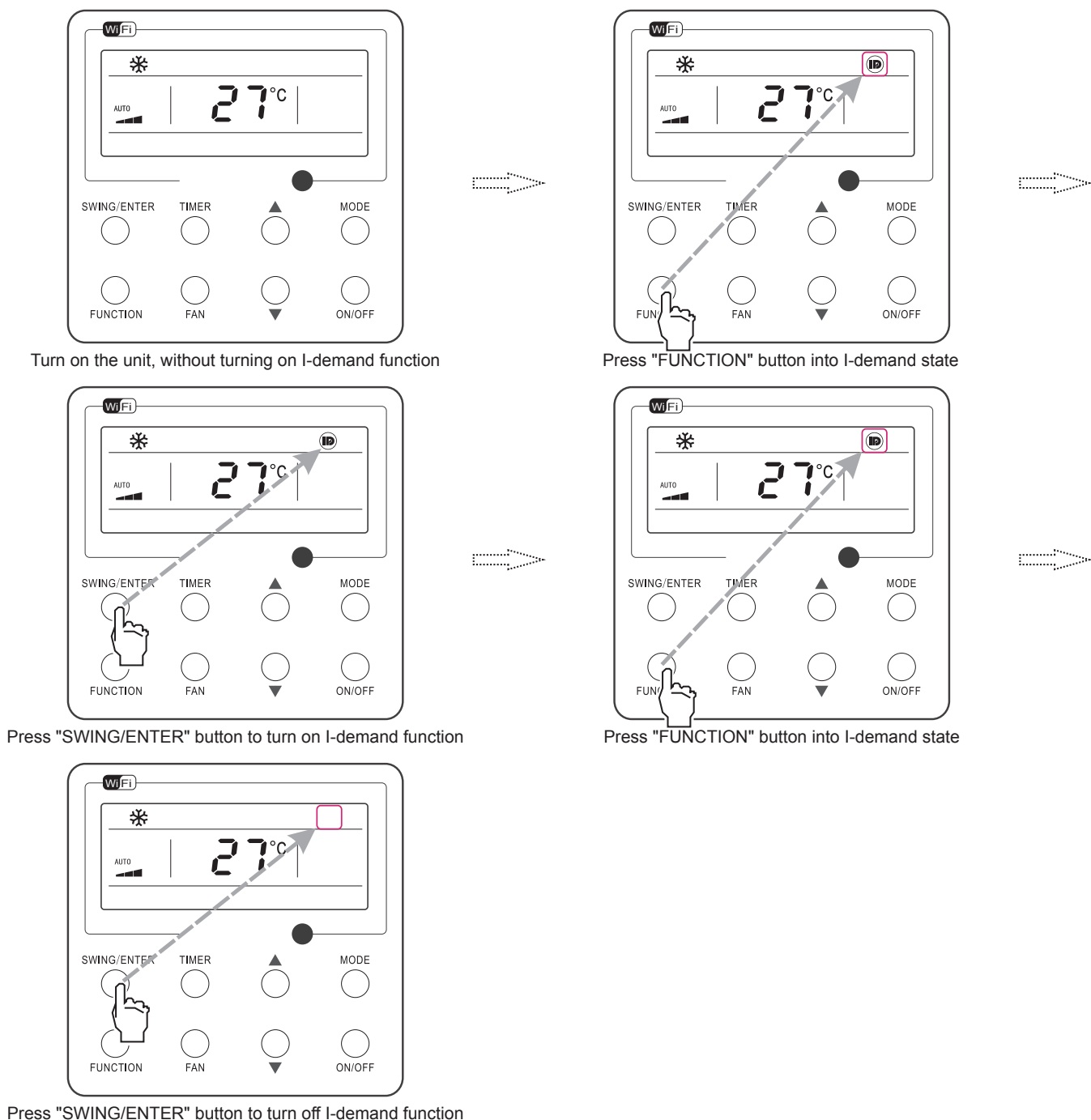

Fig. 19 I-Demand Setting

3.18 WiFi Function Setting

"Gree+" APP can be used to control it. Please scan the QR code to download it.

APP can only set some common functions of WiFi wired controller: ON/OFF, mode, set temperature, FAN speed, etc.

When using the APP for the first time, please reset the WiFi function of wired controller (reset WiFi to exfactory setting): Under off status, press "FUNCTION" + "FAN" combination buttons on its wired controller for 5 seconds. Once "°C" is displayed, this indicates that reset was successful.

If there is a communication failure for WiFi, after resetting WiFi, the temperature display area of wired controller displays "JF" for 5 seconds, which indicates that the current reset is invalid.

Press FUNCTION under on state of the unit till the unit enters the WiFi setting interface, the temperature area will display the WiFi status. Press "▲" or "▼" button to turn on WiFi ("ON" is displayed) or turn off WiFi ("OFF" is displayed), and then press "SWING/ENTER" button to confirm it.

3.19 Dred Function Setting

When outdoor unit enters DRED mode: when it detects DRED signal, the whole unit executes DRED mode. When it enters DRED mode, the outdoor unit does timekeeping and feeds back the signal to indoor unit. Under power-on state, the set temperature area displays corresponding code, DRED1, DRED2, DRED3 correspond to "d1", "d2", "d3". The panel cannot be used to set the DRED mode.

When indoor unit enters DRED mode: under power-on state, use "Function" button on the panel to switch to "DRED" function. The set temperature area will display DRED state and flicker. Through "▲" and "▼" buttons can select DRED2 (set temperature area displays d2), DRED3 (set temperature area displays d3), or turn off DRED (set temperature area displays "--"); press "SWING/ENTER" button to confirm the selection, it will display the set state for 3 seconds. After entering the setting, if there is no button operation for 5 seconds, it will quit the interface without saving the setting.

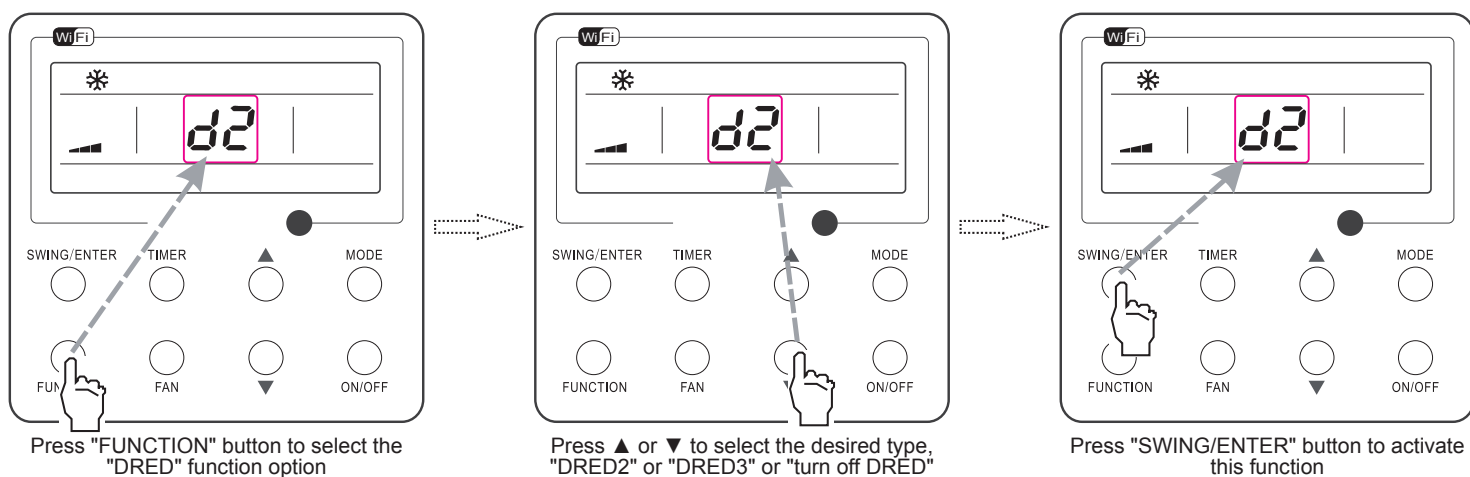

Dred Function Setting

NOTE:

- DRED mode startup method is set by indoor units.
- When outdoor unit enters DRED mode: it does not receive the DRED control of remote control, the whole unit will run the DRED mode, and the wired controller displays the state only.
- When indoor unit enters DRED mode:
 1. When the wired controller receives the DRED command sent from remote control, the set temperature area displays d2 or d3, and it will display for 3 seconds.
 2. Under power-off or air supply mode, the DRED mode is turned off.

3.20 Two-way Ventilation Function Setting

Under the "On/Off" state of the unit, press FUNCTION button on the panel to select "Two-way Ventilation" function option. Then press SWING/ENTER button to start up or turn off two-way ventilation function. When two-way ventilation function is started up,  will be shown on wired controller.

- NOTE:**
- Switch to power-off status, two-way ventilation function is turned off.
 - In power-off status, if the two-way ventilation function is activated, fan speed can be adjusted by fan speed button, and quiet or turbo function can be set.
 - This function is invalid when working with the model without two-way ventilation system.

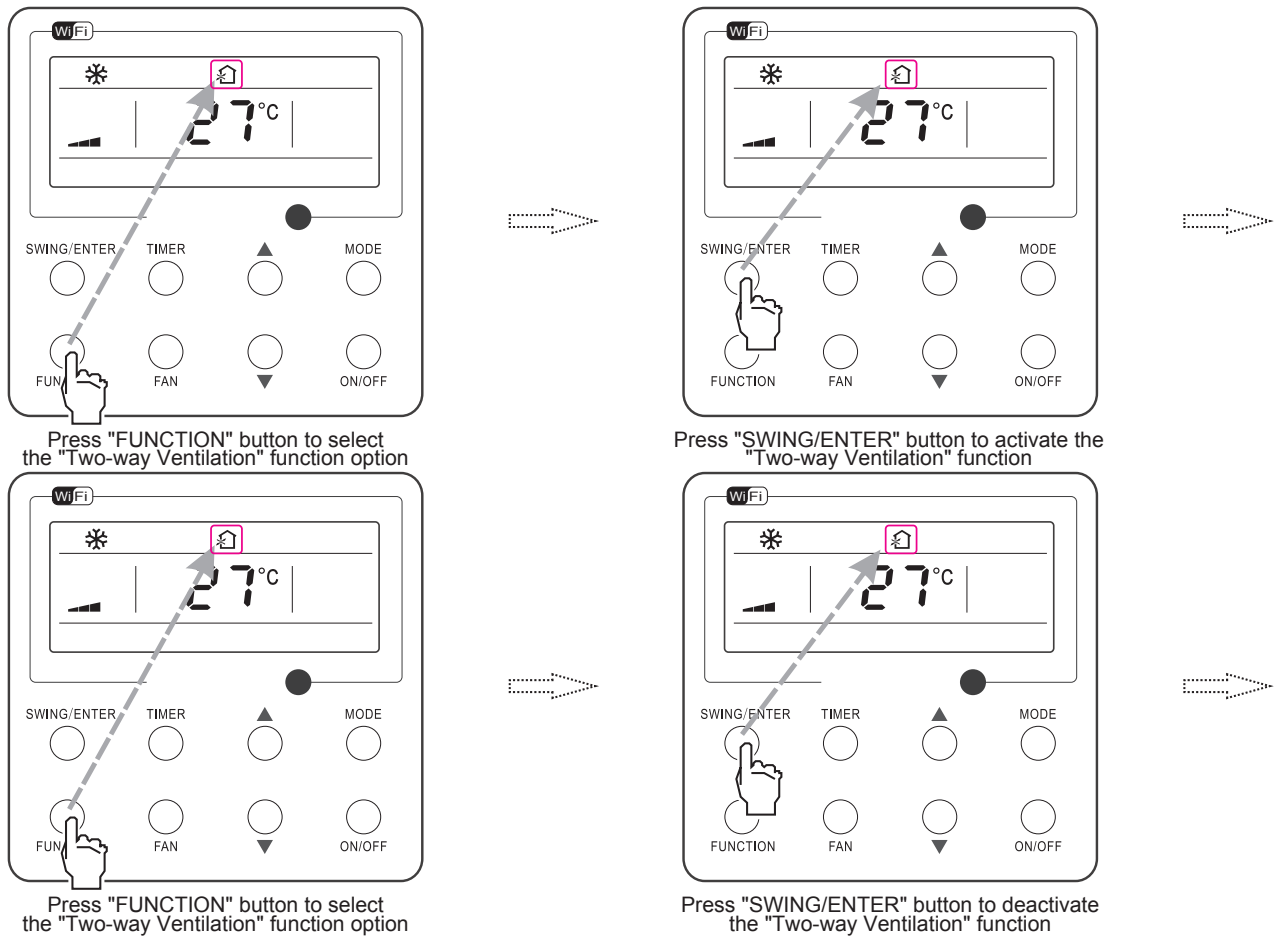

Two-way Ventilation Function Setting

3.21 Other Functions

1. Lock

Upon startup of the unit without malfunction or under the "OFF" state of the unit, press and at the same time for 5 seconds till the wired controller enters the Lock function. In this case, LCD displays . After that, repress these two buttons at the same time for 5 seconds to quit this function.

Under the Lock state, any other button press won't get any response.

2. Memory

Memory switchover: Under the "OFF" state of the unit, press Mode and at the same time for 5 seconds to switch memory states between memory on and memory off. When this function is activated, Memory will be displayed. If this function is not set, the unit will be under the "OFF" state after power failure and then power recovery.

Memory recovery: If this function has been set for the wired controller, the wired controller after power failure will resume its original running state upon power recovery. Memory contents: ON/OFF, Mode, set temperature, set fan speed and Lock function.

3. Selection of the Temperature Sensor

Under OFF state of the unit, press both "FUNCTION" and "TIMER" for five seconds to go the commissioning status. Under this status, adjust the display in the temperature display area to "00" through the button "MODE", and then adjust the option of the temperature sensor in the timer display area through the button ▲ or ▼.

- (1) Indoor ambient temperature is sensed at the return air inlet (01 in the timer display area).
- (2) Indoor ambient temperature is the sensed at the wired controller (02 in the timer display area).
- (3) Select the temperature sensor at the return air inlet under the cooling, dry and fan modes, while select the temperature sensor at the wired controller under the heating and auto modes. (03 in the timer display area).
- (4) Select the temperature sensor at the wired controller under the cooling, dry and fan modes, and select the temperature sensor at the return air inlet under the heating mode and auto modes (04 displayed in the timer display area).

After the setting, press "SWING/ENTER" to make a confirmation and quit this setting status.

Pressing the button "ON/OFF" also can quit this commissioning status but the set data won't be memorized.

Under the commissioning status, if there is no any operation in 20 seconds after the last button press, it will back to the previous

state without memorizing the current data.

NOTE:

After connected with indoor unit, if the type of ambient temperature sensor has not been manually set, the wired controller will select the ambient temperature sensor according to the model of connected IDU; if it connects to cassette type IDU, duct type IDU, floor ceiling type IDU, ceiling type IDU, it will adopt (3), otherwise it will adopt (1). If the type of ambient temperature sensor is set manually, the wired controller will subject to the manual setting, and will not set according to automatic IDU model selection.

4. Selection of the Fan Speed

Under OFF state of the unit, press both the buttons "FUNCTION" and "TIMER" for five seconds to go to the commissioning status, and then adjust the display in the temperature display area to 01 through the button "MODE" and adjust the setting of the fan speed, which comes to two options.

01: Three low fan speeds; 02: Three high fan speeds

After the setting, press "SWING/ENTER" to make a confirmation and quit this setting status.

Pressing the button "ON/OFF" also can quit this commissioning status but the set data won't be memorized.

Under the commissioning status, if there is no any operation in 20 seconds after the last button press, it will back to the previous state without memorizing the current data.

5. Inquiry of Ambient Temperature

Under off or on status, press and hold "SWING/ENTER" button for 5 seconds to enter into ambient temperature inquiry interface, then timer area displays the ambient temperature type 01 or 02, and ambient temperature area displays the corresponding ambient temperature of corresponding type. In which, 01 refers to outdoor ambient temperature, 02 refers to indoor ambient temperature. Press "MODE" button can switch between type 01 and 02. Press buttons other than "MODE" or when the unit receives remote control signal, it will quit the inquiry status. If there is no any operation for 5 seconds, it will quit automatically.

6.2 Brief Description of Models and Functions

1. Basic function of system

(1) Cooling mode

(1) Under this mode, fan and swing operates at setting status. Temperature setting range is 16~30°C.

(2) During malfunction of outdoor unit or the unit is stopped because of protection, indoor unit keeps original operation status.

(2) Drying mode

(1) Under this mode, fan operates at low speed and swing operates at setting status. Temperature setting range is 16~30°C.

(2) During malfunction of outdoor unit or the unit is stopped because of protection, indoor unit keeps original operation status.

(3) Protection status is same as that under cooling mode.

(4) Sleep function is not available for drying mode.

(3) Heating mode

(1) Under this mode, Temperature setting range is 16~30°C.

(2) Working condition and process for heating mode:

When turn on the unit under heating mode, indoor unit enters into cold air prevention status. When the unit is stopped or at OFF status, and indoor unit has been started up just now, the unit enters into residual heat-blowing status.

(4) Working method for AUTO mode:

1. Working condition and process for AUTO mode:

a. Under AUTO mode, standard heating $T_{\text{preset}}=20^{\circ}\text{C}$ and standard cooling $T_{\text{preset}}=25^{\circ}\text{C}$. The unit will switch mode automatically according to ambient temperature.

2. Protection function

a. During cooling operation, protection function is same as that under cooling mode.

b. During heating operation, protection function is same as that under heating mode.

3. Display: Set temperature is the set value under each condition. Ambient temperature is ($T_{\text{amb.}}-T_{\text{compensation}}$) for heat pump unit and $T_{\text{amb.}}$ for cooling only unit.

4. If there's I feel function, $T_{\text{compensation}}$ is 0. Others are same as above.

(5) Fan mode

Under this mode, indoor fan operates at set fan speed. Compressor, outdoor fan, 4-way valve and electric heating tube stop operation. Indoor fan can select to operate at high, medium, low or auto fan speed. Temperature setting range is 16~30°C.

2. Other control

(1) Buzzer

Upon energization or availablely operating the unit or remote controller, the buzzer will give out a beep.

(2) Auto fan

Heating mode: During auto heating mode or normal heating mode, auto fan speed will adjust the fan speed automatically according to ambient temperature and set temperature.

(3) Sleep

After setting sleep function for a period of time, system will adjust set temperature automatically.

(4) Timer function:

General timer and clock timer functions are compatible by equipping remote controller with different functions.

(5) Memory function

memorize compensation temperature, off-peak energization value. Memory content: mode, up&down swing, light, set temperature, set fan speed, general timer (clock timer cant be memorized).

After power recovery, the unit will be turned on automatically according to memory content.

(6) Refrigerant recovery function:

(1) Enter refrigerant recycling function

Within 5min after energizing (unit ON or OFF status is ok), continuously press LIGHT button for 3 times within 3s to enter refrigerant recycling mode; Fo is displayed and refrigerant recycling function is started. At this moment, the maintenance people closes liquid valve. After 5min, stick the thimble of maintenance valve with a tool. If there is no refrigerant spraying out, close the gas valve immediately and then turn off the unit to remove the connection pipe.

(2) Exit refrigerant recycling function

After entering refrigerant recycling mode, when receive any remote control signal or enter refrigerant recycling mode for 25min, the unit will exit refrigerant recycling mode automatically. If the unit is in standby mode before refrigerant recycling, it will be still in standby mode after finishing refrigerant recycling; if the unit is in ON status before refrigerant recycling, it will still run in original operation mode.

(7) Off-peak energization function:

Adjust compressors minimum stop time. The original minimum stop time is 180s and then we change to:

The time interval between two start-ups of compressor cant be less than $180+T$ s ($0 \leq T \leq 15$). T is the variable of controller. That's to say the minimum stop time of compressor is 180s~195s. Read-in T into memory chip when refurbish the memory chip each time. After power recovery, compressor can only be started up after $180+T$ s at least.

(8) X-fan mode

When X-fan function is turned on, after turn off the unit, indoor fan will still operate at low speed for 2min and then the complete unit will be turned off. When x-fan function is turned off, after turn off the unit, the complete unit will be turned off directly.

(9) 8° heating function

Under heating mode, you can set 8° heating function by remote controller. The system will operate at 8° set temperature.

(10) Turbo fan control function

Set turbo function under cooling or heating mode to enter into turbo fan speed. Press fan speed button to cancel turbo wind.

No turbo function under auto, dry or fan mode.

7. Notes for Installation and Maintenance

Safety Precautions: Important!

Please read the safety precautions carefully before installation and maintenance.

The following contents are very important for installation and maintenance.

Please follow the instructions below.

- The installation or maintenance must accord with the instructions.
- Comply with all national electrical codes and local electrical codes.
- Pay attention to the warnings and cautions in this manual.
- All installation and maintenance shall be performed by distributor or qualified person.
- All electric work must be performed by a licensed technician according to local regulations and the instructions given in this manual.
- Be caution during installation and maintenance. Prohibit incorrect operation to prevent electric shock, casualty and other accidents.



WARNINGS

Electrical Safety Precautions:

1. Cut off the power supply of air conditioner before checking and maintenance.
2. The air condition must apply specialized circuit and prohibit share the same circuit with other appliances.
3. The air conditioner should be installed in suitable location and ensure the power plug is touchable.
4. Make sure each wiring terminal is connected firmly during installation and maintenance.
5. Have the unit adequately grounded. The grounding wire Can't be used for other purposes.
6. Must apply protective accessories such as protective boards, cable-cross loop and wire clip.
7. The live wire, neutral wire and grounding wire of power supply must be corresponding to the live wire, neutral wire and grounding wire of the air conditioner.
8. The power cord and power connection wires Can't be pressed by hard objects.
9. If power cord or connection wire is broken, it must be replaced by a qualified person.
10. If the power cord or connection wire is not long enough, please get the specialized power cord or connection wire from the manufacture or distributor. Prohibit prolong the wire by yourself.

11. For the air conditioner without plug, an air switch must be installed in the circuit. The air switch should be all-pole parting and the contact parting distance should be more than 3mm.

12. Make sure all wires and pipes are connected properly and the valves are opened before energizing.

13. Check if there is electric leakage on the unit body. If yes, please eliminate the electric leakage.

14. Replace the fuse with a new one of the same specification if it is burnt down; dont replace it with a cooper wire or conducting wire.

15. If the unit is to be installed in a humid place, the circuit breaker must be installed.

Installation Safety Precautions:

1. Select the installation location according to the requirement of this manual.(See the requirements in installation part)
2. Handle unit transportation with care; the unit should not be carried by only one person if it is more than 20kg.
3. When installing the indoor unit and outdoor unit, a sufficient fixing bolt must be installed; make sure the installation support is firm.
4. Ware safety belt if the height of working is above 2m.
5. Use equipped components or appointed components during installation.
6. Make sure no foreign objects are left in the unit after finishing installation.

Refrigerant Safety Precautions:

1. When refrigerant leaks or requires discharge during installation, maintenance, or disassembly, it should be handled by certified professionals or otherwise in compliance with local laws and regulations.
- 2.Avoid contact between refrigerant and fire as it generates poisonous gas; Prohibit prolong the connection pipe by welding.
3. Apply specified refrigerant only. Never have it mixed with any other refrigerant. Never have air remain in the refrigerant line as it may lead to rupture or other hazards.
4. Make sure no refrigerant gas is leaking out when installation is completed.
5. If there is refrigerant leakage, please take sufficient measure to minimize the density of refrigerant.
6. Never touch the refrigerant piping or compressor without wearing glove to avoid scald or frostbite.

Improper installation may lead to fire hazard, explosion, electric shock or injury.

8. Installation

8.1 Dimension Requirements on the Installation Space of the Indoor Unit

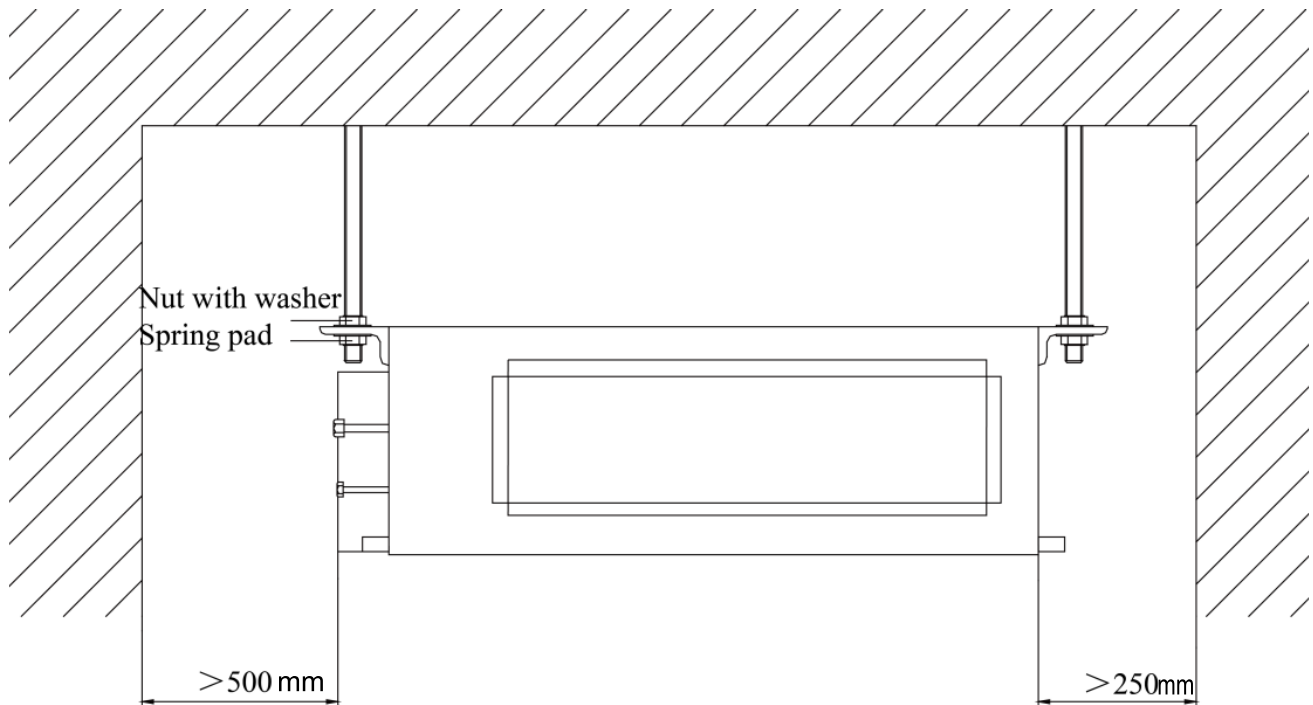

Fig. 2

8.2 Installation of the Indoor Unit

a. Requirements on the Installation Location

- 1) Ensure the hanger is strong enough to withstand the weight of the unit.
- 2) The drainage of the drain pipe is easy.
- 3) No obstacle is in the inlet/outlet and the air circulation is in good condition.
- 4) Ensure the installation space shown in Fig.2 is left for the access to maintenance.
- 5) It should be far away from where there is heat source, leakage of inflammable, explosive substances, or smog.
- 6) It is the ceiling type unit (concealed in the ceiling).
- 7) The power cords and connection lines of the indoor and outdoor units must be at least 1m away from the TV set or radio to avoid the image interference and noise (even if 1m is kept, the noise may be produced due to the strong electric wave).

b. Installation of the Indoor Unit

- 1) Insert the M10 expansion bolt into the hole, and then knock the nail into the bolt. Refer to the Outline Dimension Drawings of the Indoor Unit for the distance between holes and see Fig.3 for the installation of the expansion bolt.

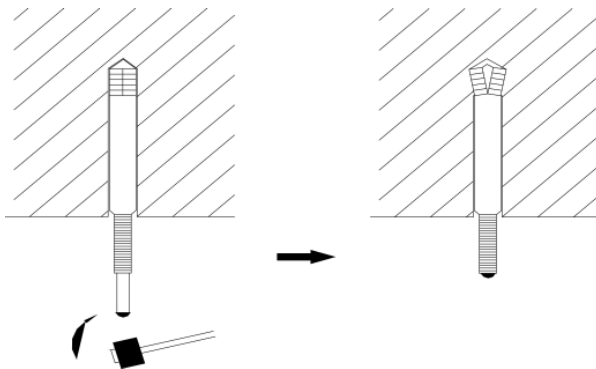

Fig. 3

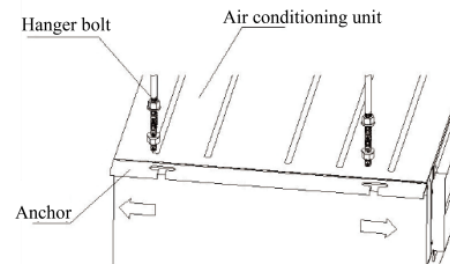

Fig. 4

Install the hanger on the indoor unit, as shown in Fig.4.

Install the indoor unit on the ceiling, as shown in Fig.5.

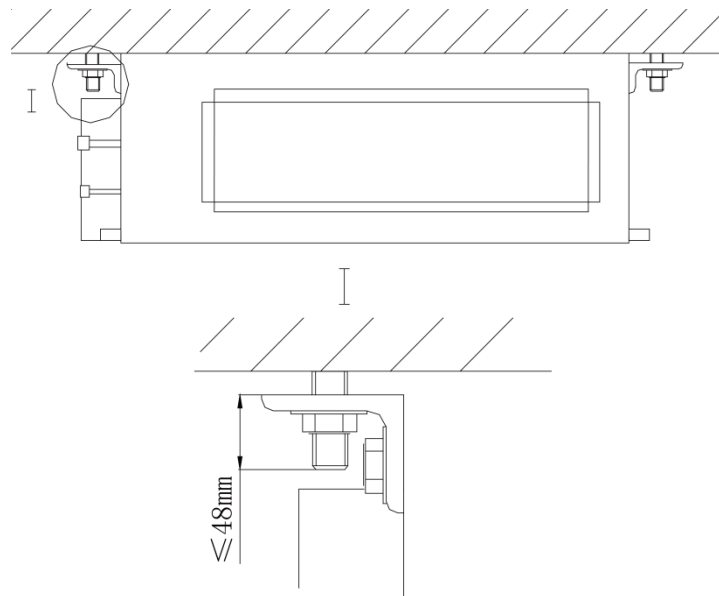

Fig. 5

⚠ CAUTION!

1. Prior to the installation, please make a good preparation for all piping (refrigerant pipe, drain pipe) and wiring (wires of the wired controller, wires between the indoor and outdoor unit) of the indoor unit to make the further installation much easier.
2. If there is an opening in the ceiling, it is better to reinforce it to keep it flat and prevent it vibrating. Consult the user and builder for more details.
3. If the strength of the ceiling is not strong enough, a beam made of angle iron can be used and then fix the unit on it.
4. If the indoor unit is not installed in the air conditioning area, please use sponge around the unit to prevent condensing. The thickness of the sponge depends on the actual installation environment.

8.3 Horizontality Check of the Indoor Unit

After the installation of the indoor unit, its horizontality must be checked to make sure the unit keep horizontal fore and aft and keep an inclination of 5° toward the drain pipe right and left, as shown in Fig.6.

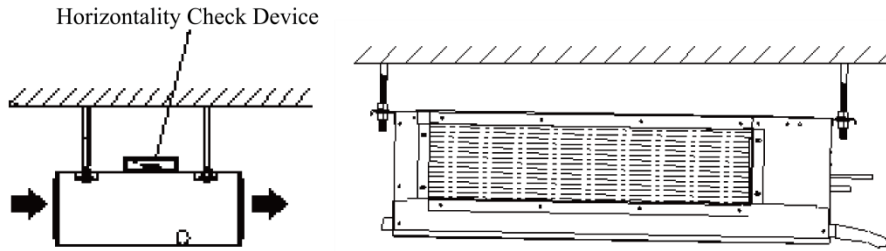

Fig. 6

8.4 Installation of the Air Supply Duct

a. Installation of the Rectangular Air Supply Duct

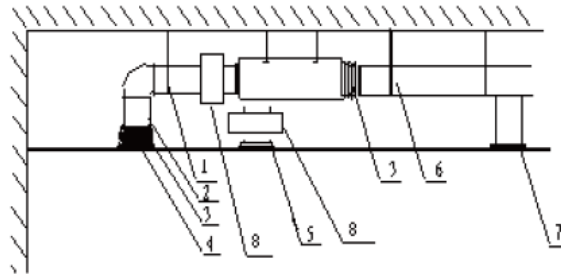
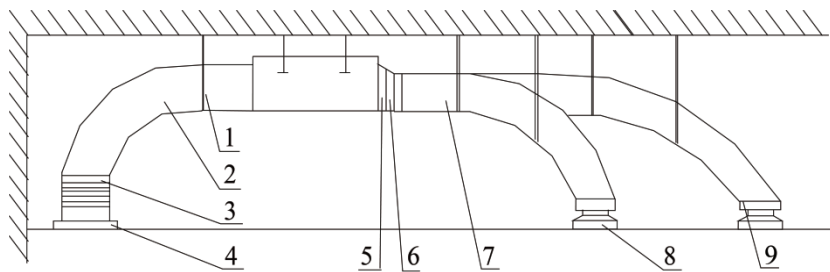

Fig. 7

No.	Name	No.	Name
1	Hanger	5	Filter Screen
2	Return Air Duct	6	Main Air Supply Duct
3	Canvas Duct	7	Air Supply Outlet
4	Return Air Inlet	8	Plenum Box

b. Installation of the Round Air Supply Duct



No.	Name	No.	Name
1	Hanger	6	Transition Duct
2	Return Air Duct	7	Air Supply Duct
3	Canvas Duct	8	Diffuser
4	Return Air Louver	9	Diffuser Joint
5	Air Supply Outlet		

c. Installation Steps of the Round Air Supply Duct

- 1) Preinstall the outlet of the round duct on the transition duct and then fix it by the self-tapping screw.
- 2) Place the transition duct to the air outlet of the unit and fix it with rivet.
- 3) Connect the outlet to the duct and then tighten them with tape. Other installation details are not covered herein.

⚠ CAUTION!

1. The maximum length of the duct means the maximum length of the air supply duct plus the maximum length of the return air duct.
2. For the unit with the auxiliary electric heating function, if the round duct is to be adopted, then the straight length of the transition duct can not be less than 200mm.
3. The duct is either rectangular or round and connected with the air inlet/outlet of the indoor unit. Among all air supply outlets, at least one should be kept open. As for the round duct, it needs a transition duct of which the size should match with the air supply outlet of the unit. After the fitting of the transition duct, it is the turn of the round duct, which is better to be kept 10 meters far away from the corresponding diffuser. The standard accessories supplied is the transition duct 200mm long and round air outlet $\phi 200$, however, those of other specifications can be purchased.

8.5 Drawings of the Air Supply Outlet and Return Air Inlet

capacity:2.5~6.0kW

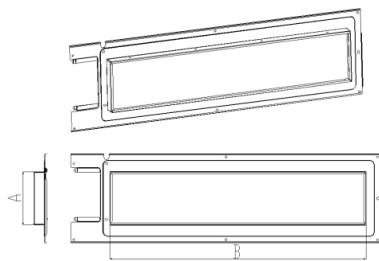

Fig.9 Air Supply Outlet

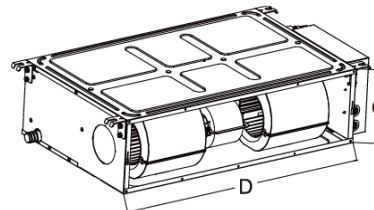

Fig.10 Return Air Inlet

Dimensions of the Air Supply Outlet and Return Air Inlet (unit: mm)

Model	Item	Dimension of air outlet flange		Dimension of air return	
		A	B	C	D
09K/12K		122	585	200	710
18K		122	885	200	1010

8.6 Installation of the Return Air Duct

- a. The default installation location of the rectangular flange is in the back and the return air cover plate is in the bottom, as shown in Fig.11.

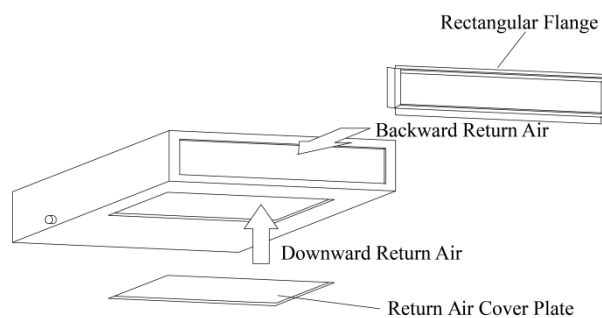

Fig.11

- b. If the downward return air is desired, just change the place of the rectangular flange and the return air cover plate.
- c. Connect one end of the return air duct to the return air outlet of the unit by rivets and the other to the return air louver. For the sake of the convenience to freely adjust the height, a cutting of canvas duct will be helpful, which can be reinforce and folded by 8 # iron wire.
- d. More noise is likely to be produced in the downward return air mode than the backward return air mode, so it is suggestive to install a silencer and a plenum box to minimize the noise.
- e. The installation method can be chose with considering the conditions of the building and maintenance etc., as shown in Fig.12.

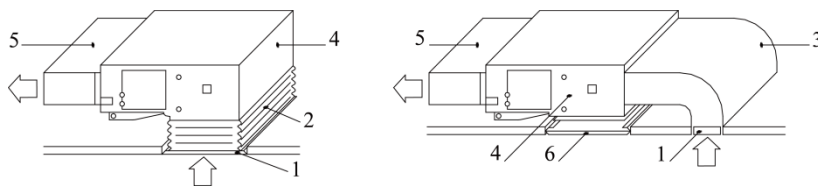

Fig.12

Parts and Components of the Return Air Duct

No.	Name	No.	Name
1	Return Air Louver(with the filter screen)	4	Indoor Unit
2	Canvas Duct	5	Air Supply Duct
3	Return Air Duct	6	Access Grille

8.7 Installation of the Condensate Pipe

a. The condensate pipe should keep a inclination angle of 5~10°, which can facilitate the drainage of the condensate water. And the joints of the condensate pipe should be insulated by the insulation material to prevent condensing(see Fig.13).

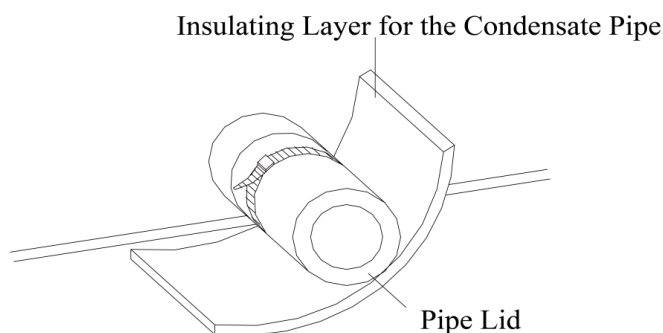

Fig.13 Thermal Insulation of the Condensate Pipe

b. There is a condensate outlet on both left and right sides of the unit. Once one is confirmed to be used, the other should be clogged by a rubber plug, bundled by the binding wire and insulated by the insulation material to avoid water leakage.

c. The right outlet is defaulted to be clogged with a plug.

⚠ CAUTION!

No water leakage is allowed on the joint of the condensate pipe.

8.8 Design of the Drain Pipe

a. The drain pipe should always keep an inclination angle(1/50~1/100) to avoid the water gathering in some certain place.

b. During the connection of the drain pipe and device, do not impose too much force on the pipe on one side of the device and the pipe should be fixed as close as to the device.

c. The drain pipe can be the ordinary hard PVC pipe which can be purchased locally. During the connection, inset the end of the PVC pipe to the drain outlet, then tighten it with the drain hose and binding wire but never connect the drain outlet and the drain hose by adhesive.

d. When the drain pipe is used for multiple devices, the public section of the pipe should be 100mm lower than the drain hole of each device and it is better to use the much thicker pipe for such a purpose.

8.9 Installation of the Drain Pipe

a. The diameter of the drain pipe should be larger or equal to that of the refrigerant pipe (PVC pipe, outer diameter:25mm, wall thickness≥1.5mm).

b. The drain pipe should be as short as possible and with at least a 1/100 degree of slope to avoid forming air pockets.

c. If the proper degree of slope of the drain pipe is not allowed, a lift pipe should be installed.

d. A distance 1-1.5m should be kept between the hangers to avoid the drain hose making a turn.

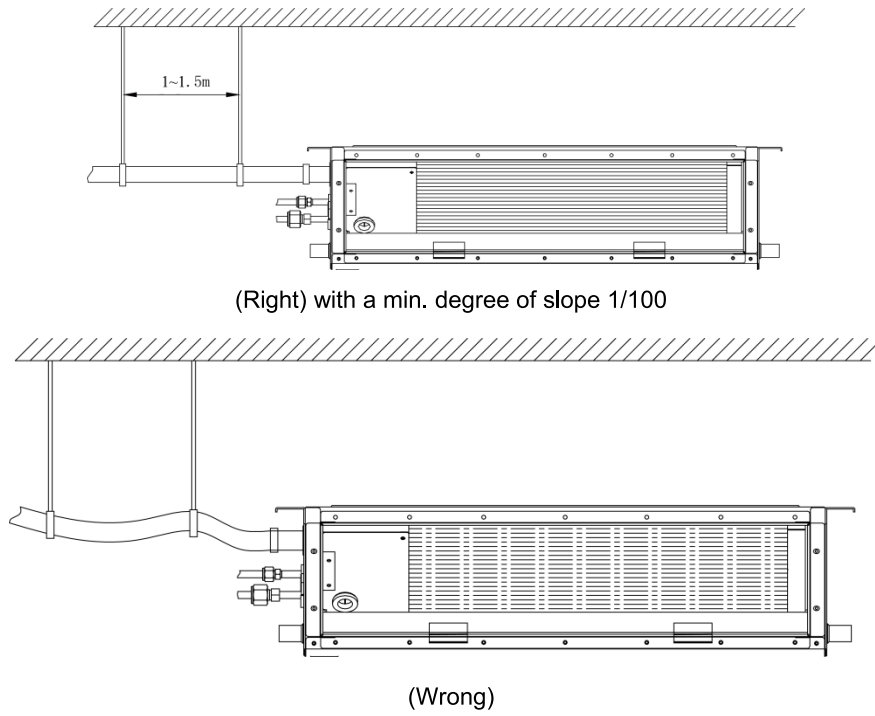

Fig.14

- e. Insert the drain hose into the drain hole and tighten it with clamps.
- f. Wrap the clamps with large amount of sponge for thermal insulation.
- g. The drain hose inside the room also should be insulated.

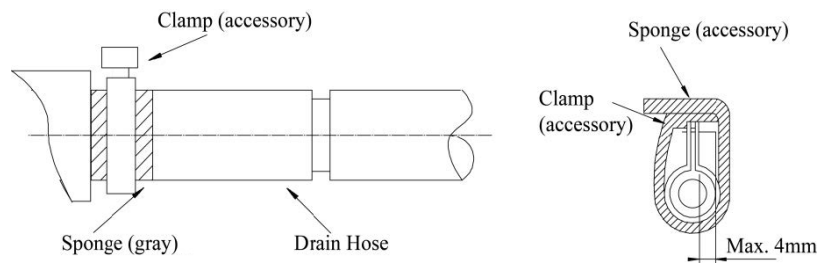

Fig.15

8.10 Precautions for the Lift Pipe

The installation height of the lift pipe should be less than 850mm. It is recommended to set an inclination angle $1^{\circ}\sim 2^{\circ}$ for the lift pipe toward the drainage direction. If the lift pipe and the unit form a right angle, the height of the lift pipe must be less than 800mm.

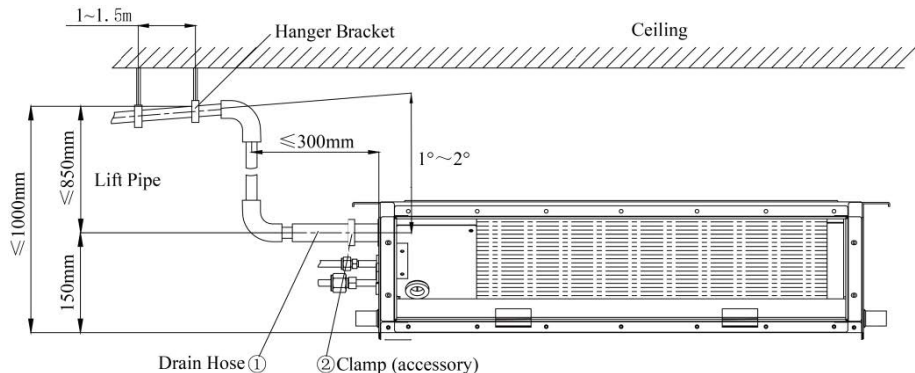
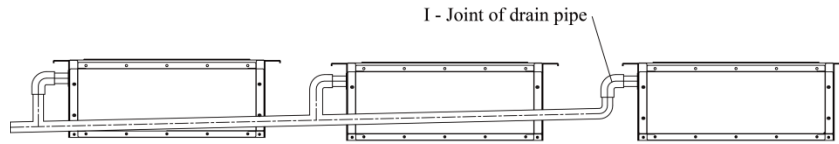

Fig.16

- Notes:**
1. The inclination height of the drain hose should be within 75mm so that the outlet of the drain hose does not suffer the external force.
 2. If multiple drain pipes converge, please follow the installation steps below.



The specification of the joint of the drain pipe should be suitable to the running capacity of the unit

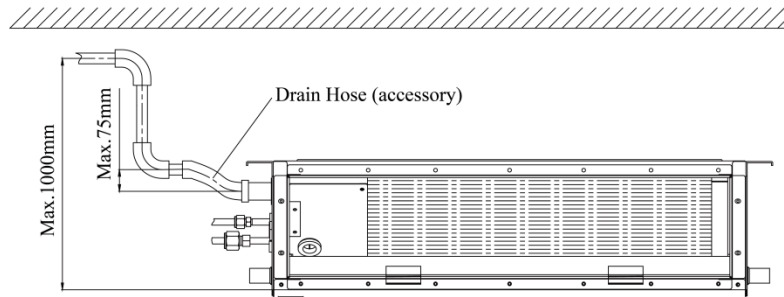

Fig.17

8.11 Test for the Drainage System

- a. After the electric installation, please take a test for the drainage system.
- b. During the test, check if the water flow goes through the pipe correctly and observe carefully the joint to see if it leaks or not. If this unit is installed in the newly built house, it is suggested to take this test prior to the ceiling decoration.

8.12 Piping

- a. Let the flare end of the copper pipe point at the screw and then tighten the screw by hand.
- b. After that, tighten the screw by the torque wrench unit it clatters (as shown in Fig.18).

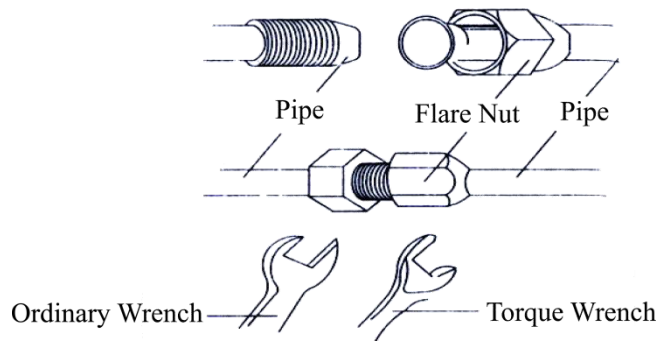

Fig.18

Moments of Torque for Tightening Screws

Diameter of Pipe(mm)	Moment of Torque (N·m)
Φ 6.35(1/4)	15-30
Φ 9-9.52(3/8)	35-40
Φ 12(1/2)	45-50
Φ 15.9(5/8)	60-65

- a. The bending degree of the pipe can not be too small; otherwise it will crack. And please use a pipe bender to bend the pipe.
- b. Wrap the exposed refrigerant pipe and the joints by sponge and then tighten them with the plastic tape.

⚠ CAUTION!

1. During the connection of the indoor unit and the refrigerant pipe, never pull any joints of the indoor unit by force; otherwise the capillary pipe or other pipe may crack, which then would result in leakage.
2. The refrigerant pipe should be supported by brackets, that is, don't let the unit withstand the weight of it.

8.13 Insulation for the refrigerant pipe

- a. The refrigerant pipe should be insulated by the insulating material and plastic tape in order to prevent condensing and leaking.
- b. The joints of the indoor unit should be wrapped with the insulating material and no gas is allowed on the joint of the indoor unit, as shown in Fig.19.

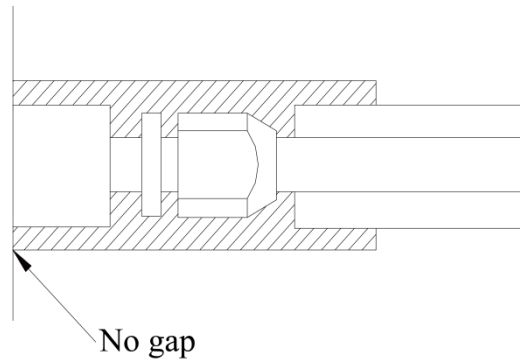

Fig.19

⚠ CAUTION!

After the pipe is protected well enough, never bend it to form a small angle; otherwise it would crack or break.

c. Wrapping the pipe with tape.

- 1) Bundle the refrigerant pipe and electric wire together with tape, and separate them from the drain pipe to prevent the condensate water overflowing.
- 2) Wrap the pipe from the bottom of the outdoor unit to the top of the pipe where it enters the wall. During the wrapping, the later circle should cover half of the former one.
- 3) Fix the wrapped pipe on the wall with clamps.

⚠ CAUTION!

1. Do not wrap the pipe too tightly; otherwise the insulation effect would be weakened. Additionally, make sure the drain hose is separated from the pipe
2. After that, fill the hole on the wall with sealing material to prevent wind and rain coming into the room.

8.14 Wiring between the Wire and the Wiring Terminal

a. Wiring of the Single-Core Wire

- 1) Strip the insulating layer at the end of the wire about 25mm off with a wire stripper.
- 2) Loosen the screw off on the wiring board of the air conditioning unit.
- 3) Shape with the pliers the end of the wire to a circle matching with the size of the screw.
- 4) Let the screw go through the circle of the wire and then fix it on the wiring board.

b. Wiring of the Multi-Core Wire

- 1) Strip the insulating layer at the end of the wire about 10mm off with a wire stripper.
- 2) Loosen the screw off on the wiring board of the air conditioning unit.
- 3) Fix a wiring terminal matching with the size of the screw to the end of the multi-core wire with the crimping pliers.
- 4) Let the screw go through the terminal of the multi-core wire and then fix it on the wiring board.

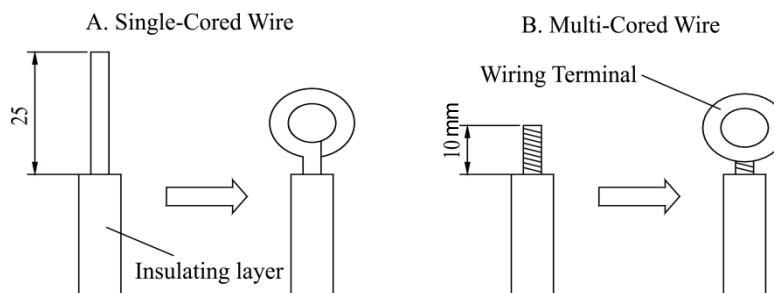

Fig.20

⚠ WARNING!

1. If the power cord is damaged, they must be replaced with the dedicated one.
2. Prior to the wiring, please check the voltage marked on the nameplate and then carries out the wiring following the wiring diagram.
3. The dedicated power cord must be used for the air conditioning unit and the leakage current protection switch and air switch must be installed in case of the overload condition.
4. The air conditioning unit must be earthed to prevent the hazard caused by the failed insulation.
5. During the wiring, the wiring terminal or the single-core wire must be used; the direct wiring between the multi-core wire and wiring board would cause fire.
6. All wiring should be done strictly in accordance with the wiring diagram; otherwise the improper wiring would cause the air conditioning unit running abnormally or damaged.
7. Do not let the electric wires touch the refrigerant pipe, the compressor, the fan or other moving parts.
8. Do not modify the wiring inside the indoor unit randomly; otherwise the manufacturer won't assume any responsibility for the damage or abnormal running of the unit.

8.15 Wiring of the Power Cord (single-phase)

⚠ CAUTION!

The power supply for each indoor unit must be uniform.

1. Dismantle the cover of the electric box of the indoor unit.
2. Let the power cord go through the rubber ring.
3. Connect the wiring (communication) through the piping hole of the chassis and the bottom of the appliance upward, then connect the brown wire to the Terminal board "3";black wire(the communication wire) to the Terminal board"2";blue wire to the Terminal board"N(1)",and connect the earthing wire to the screw terminal on the electric box. Clamp them with the corresponding wire clamp packed in the chassis.
4. Fix the power cord tightly with the binding wire.

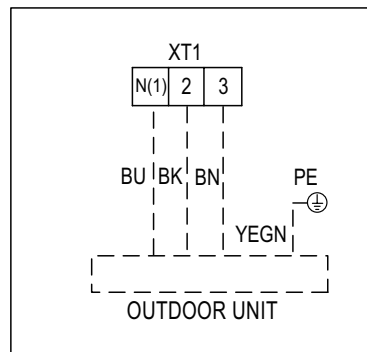

Fig.21

8.16 Installation and Dismantlement for Wired Controller

1. Connection of the Signal Line of the Wired Controller

- Open the cover of the electric control box of the indoor unit.
- Let the single line of the wired controller through the soleplate of wired controller.
- Connect the signal line of the wired controller to the 4-pin socket of the indoor unit.
- The communication distance between the main board and the wired controller can be up to 20 meters (the standard distance is 8 meters)

2. Installation of the Wired Controller

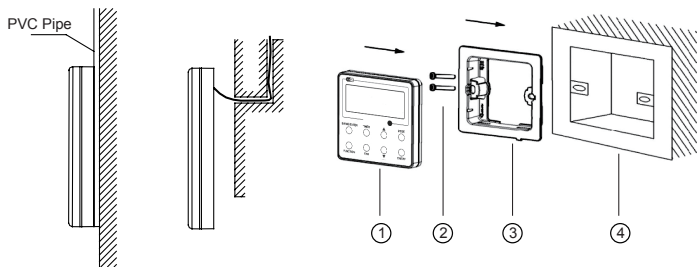

Fig. 22 Accessories for the Installation of the Wired Controller

Table 3

No.	1	2	3	4
Name	Front Panel of the Wired Controller	Screw M4X25	Soleplate of the Wired Controller	Controller embedded in the wall

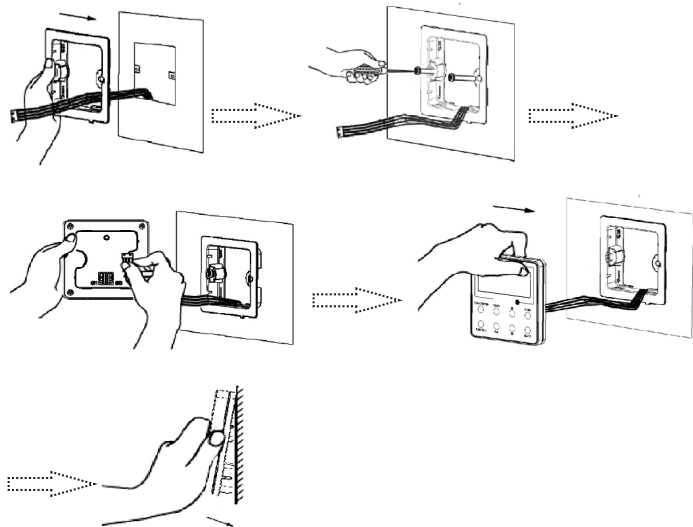

Fig. 23

NOTE:

CN1 is 485 communication interface and it used Wired Controller XE73-44/E for connecting the 4-core communication wire. These two needle stands (CN2, CN3) are used for connecting the smart zone controller. There is no sequence for these two needle

stands. You can connect one or two needle stand(s) basing on the requirement.

Fig. 23 shows the installation steps of the wired controller, but there are some issues that need your attention.

- (1) Prior to the installation, please firstly cut off the power supply of the wire buried in the installation hole, that is, no operation is allowed with electricity during the whole installation.
- (2) Pull out the four-core twisted pair line from the installation holes and then let it go through the rectangular hole behind the soleplate of the wired controller.
- (3) Stick the soleplate of wired controller on the wall and then use screw M4×25 to fix soleplate and installation hole on wall together.
- (4) Insert the four-core twisted pair line into the slot of the wired controller and then buckle the front panel and the soleplate of the wired controller together.

For matching with different models, the patch cord and the connection wire are provided in the packaging box of wired controller. As shown in Fig. 24.

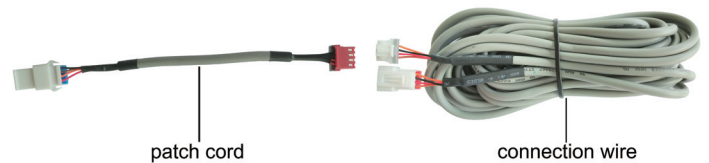

Fig. 24: Schematic diagram of patch cord and connection wire

- If the air conditioner has been installed with the patch cord (Fig. 24) used for connecting the wired controller.

Only use the connection wire (Fig. 25) in the packing box of wired controller. Connect the terminal ② to the terminal ④ of patch cord which has been installed on the air conditioner; insert terminal ① to needle stand CN1 of wired controller. If there's protection terminal ③, pull out the protection terminal at first and then install it.

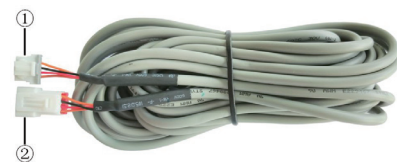

Fig. 25: Schematic diagram of connection wire: Connect terminal ① with wired controller CN1; connect terminal ② with the terminal ④ of patch cord



Fig. 26: Schematic diagram of patch cord: Terminal ③ is the protection terminal; connect terminal ④ to the terminal ② of connection wire; connect terminal ⑤ to the terminal of wired controller of air conditioner

- If the air conditioner hasn't been installed with the patch cord used for connecting the wired controller.

Use the connection wire and patch cord in the packing box of wired controller. Pull out the protection terminal of patch cord at first, connect the connection wire with the patch cord according to Fig. 27, and then insert the terminal ① of connection wire into the needle stand CN1 of wired controller and insert the terminal ⑤ of patch cord into the terminal of wired controller of air conditioner as well.

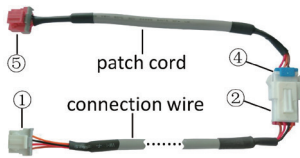

Fig. 27: Schematic diagram after the connection wire and the patch cord have been connected: connect the terminal ② of connection wire and the terminal ④ of patch cord

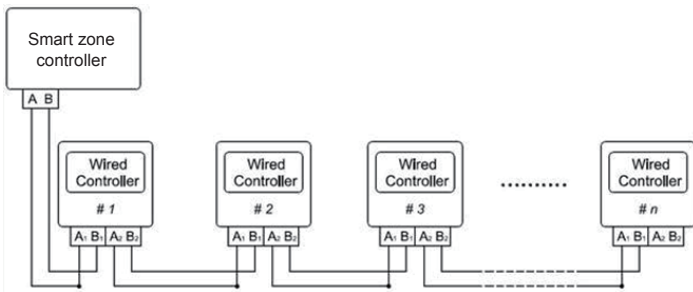

Fig. 28

Fig. 28 shows the schematic diagram of control system connection. XE73-44/E can connect the smart zone controller (integrated control system). "n" indicates the number of communication node address (programmable wired controller XE73-44/E). The complete system is composed of the smart zone controller, wired controller XE73-44/E and communication cable. The wired controller XE73-44/E can support 16 communication node addresses at the most ($n \leq 16$).

Terminal A and terminal B of the smart zone controller are respectively connected to the corresponding communication needle stand terminal of the #1 wired controller by the communication cable; the other needle stand of #1 wired controller is connected to the #2 wired controller through the telecommunication cable and so forth until connect to the #n wired controller. Except the last wired controller in the control system (only use CN2 or CN3, and the other one will not be connected), there's no the sequence and the importance for the wired controller. The series number in the figure is only for the sake of clarity.

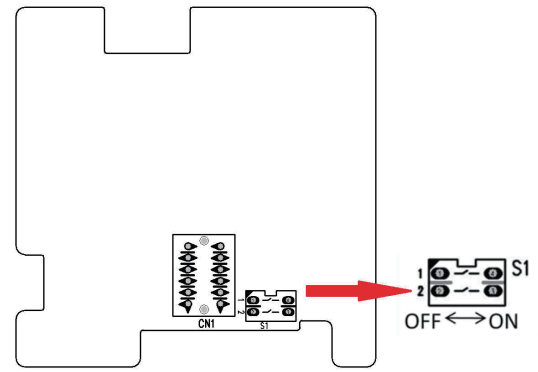

Fig. 29

Fig. 29 shows schematic diagram of DIP switch. There is a 2-bit DIP switch on the main board of wired controller XE73-44/E. As for the last #n wired controller in the control system, the 1-bit and the 2-bit of the DIP switch should be manually pulled to position "on" and position "off" respectively. The DIP switches of other wired controllers should be kept at the initial ex-factory status (1-bit and 2-bit are set at position "off").

CAUTION!

Please pay special attention to the followings during the connection to avoid the malfunction of the air conditioning unit due to electromagnetic interference.

(1) Separate the signal and communication lines of the wired controller from the power cord and connection lines between the indoor and outdoor unit, with a minimum interval of 20cm, otherwise the communication of the unit will probably work abnormally.

(2) If the air conditioning unit is installed where is vulnerable to electromagnetic interference, then the signal and communication lines of the wired controller must be the shielding twisted pair lines.

3. Dismantlement of the Wired Controller

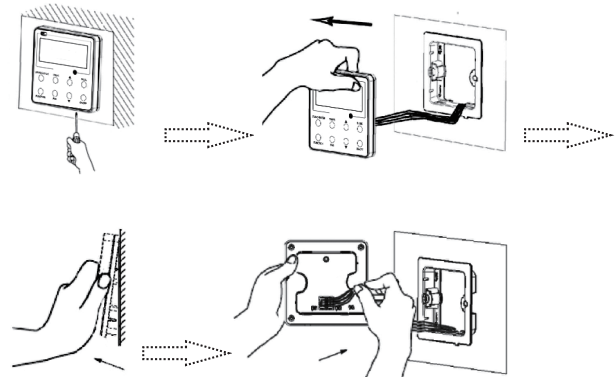

9. Maintenance

9.1 Error Code List

If there is an error occurring during the operation of the system, the error code will be displayed on the LCD, as show in Fig. 30. If multi errors occur at the same time, their codes will be displayed circularly.

NOTE: In event of any error, please turn off the unit and contact the professionally skilled personnel.

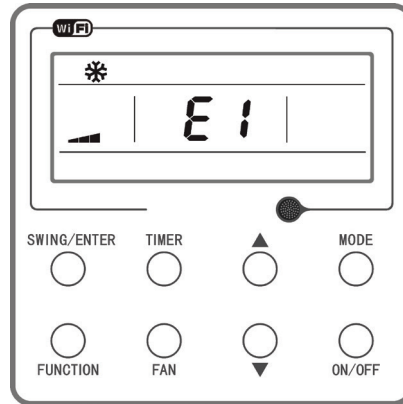

Fig. 30

Error	Error Code	Error	Error Code
Return air temperature sensor open/short circuited	F1	PFC protection	Hc
evaporator temperature sensor open/short circuited	F2	IPM Temperature Protection	P8
Indoor unit liquid valve temperature sensor open/short circuited	b5	Over-power protection	L9
Indoor gas valve temperature sensor open/short circuited	b7	System charge shortage or blockage protection	F0
IPM temperature sensor open/short circuited	P7	Capacitor charging error	PU
Outdoor ambient temperature sensor open/short circuited	F3	High pressure protection	E1
Outdoor unit condenser mid-tube temperature sensor open/short circuited	F4	Low pressure protection	E3
Discharge temperature sensor open/short circuited	F5	Compressor stalling	LE
Indoor and outdoor communication error	E6	Over-speeding	LF
DC bus under-voltage protection	PL	Drive board temperature sensor error	PF
DC bus over-voltage protection	PH	AC contactor protection	P9
Compressor phase current sensing circuit error	U1	Temperature drift protection	PE
Compressor demagnetization protection	HE	Sensor connection protection	Pd

Error	Error Code	Error	Error Code
DC bus voltage drop error	U3	Frequency restricted/reduced with whole unit current protection	F8
Outdoor fan 1 error protection	L3	Frequency restricted/reduced with IPM current protection	En
Outdoor fan 2 error protection	LA	Frequency restricted/reduced with high discharge temperature	F9
compressor inhalation temperature sensor error	dc	Frequency restricted/reduced with anti-freezing protection	FH
Drive board communication error	P6	Frequency restricted/reduced with overload protection	F6
Compressor overheating protection	H3	Frequency restricted/reduced with IPM temperature protection	EU
Indoor and outdoor units unmatched	LP	Indoor unit full water error	E9
Communication line misconnected or expansion valve error	dn	Anti-freezing protection	E2
Running mode conflict	E7	AC input voltage abnormal	PP
Pump-down	Fo	Whole unit current sensing circuit error	U5
Defrost or oil return		4-way valve reversing error	U7
Forced defrosting	H1	Motor stalling	H6
Compressor startup failure	Lc	PG motor zero-crossing protection	U8
High discharge temperature protection	E4	Indoor fan tripping error	U0
Overload protection	E8	Communication error between IDU and grid connection	Ln
Whole unit over-current protection	E5	Communication error between ODU and grid connection	LM
Over phase current protection	P5	Main error at grid connection side	y2
Compressor desynchronizing	H7	IDU network address error	y3
IPM Current protection	H5	Ip address allocation overflow	yb
Compressor phase loss/reversal protection	Ld		

9.2 Procedure of Troubleshooting

1. Malfunction of Temperature Sensor F1, F2

Main detection points:

- Is the wiring terminal between the temperature sensor and the controller loosened or poorly contacted?
- Is there short circuit due to trip-over of the parts?
- Is the temperature sensor broken?
- Is mainboard broken?

Malfunction diagnosis process:

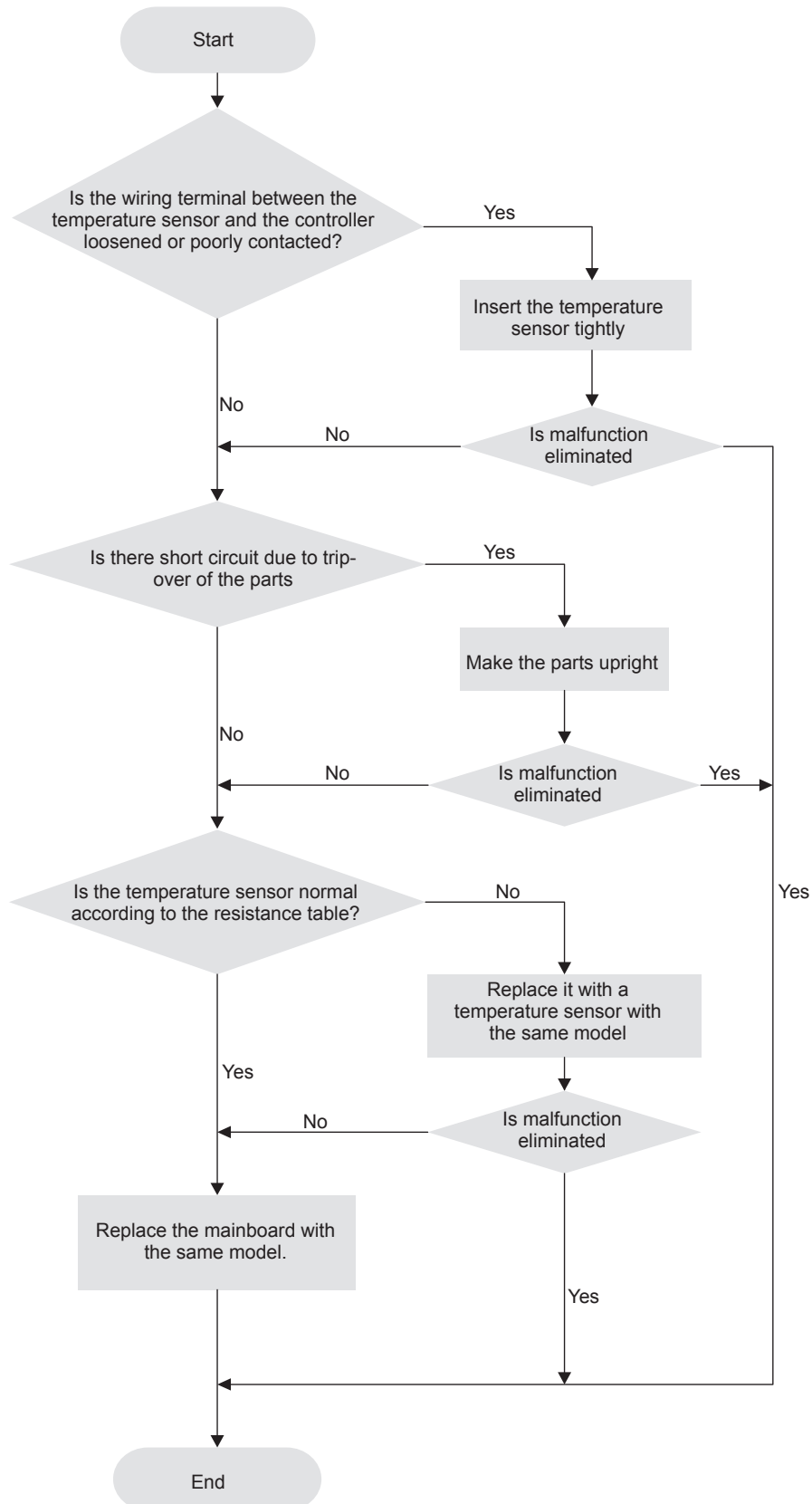

2. Communication malfunction E6

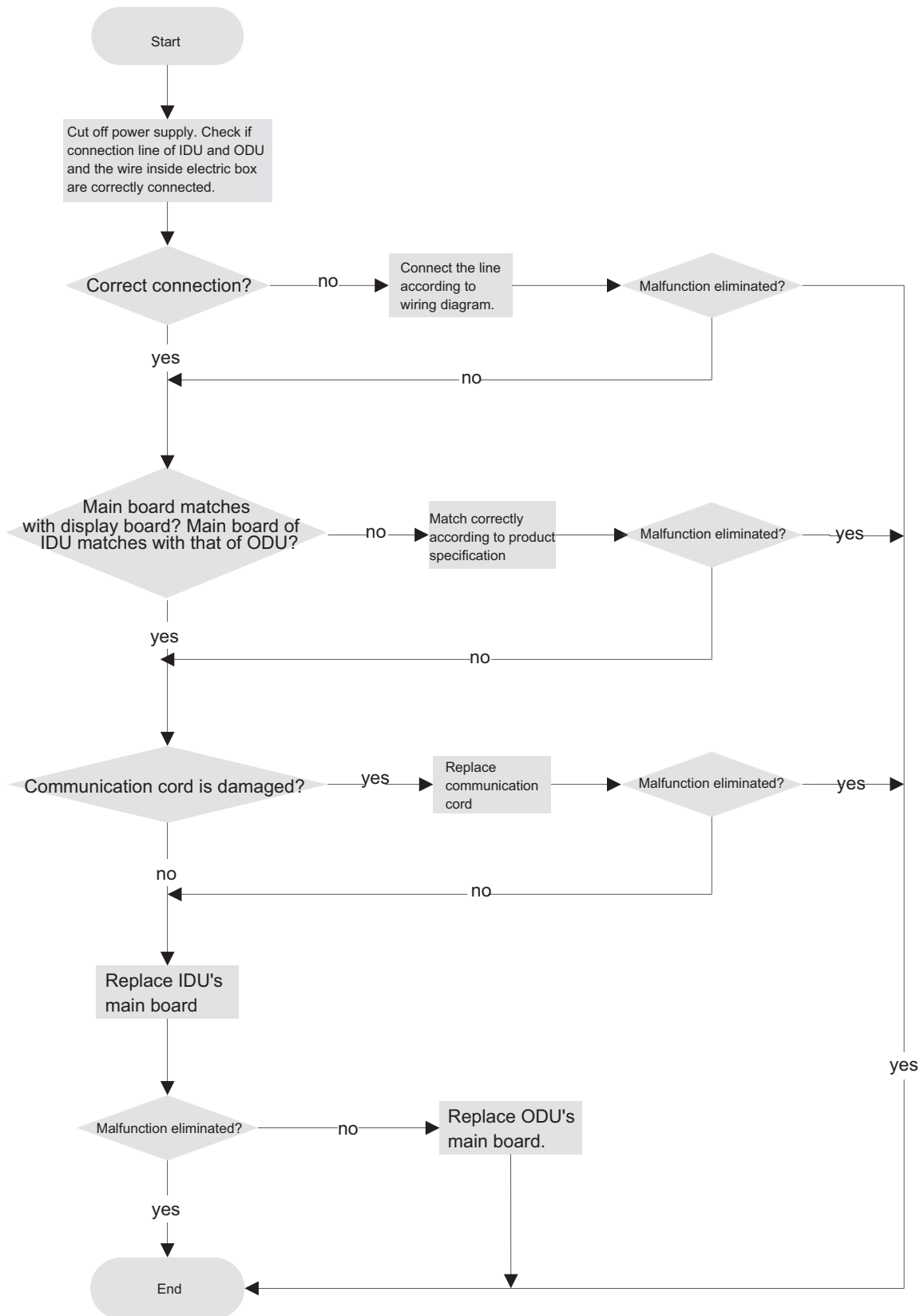

3. Full Water Protection E9

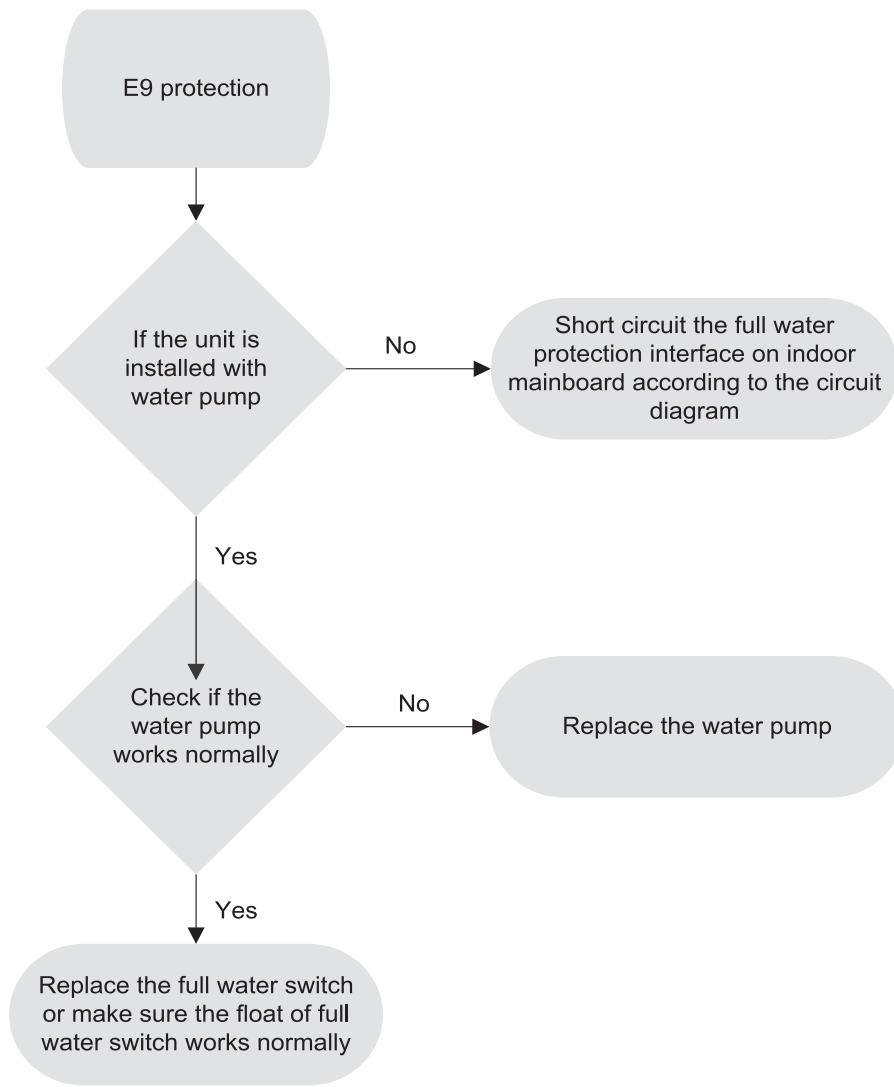

4. Malfunction of Insufficient fluorine protection F0

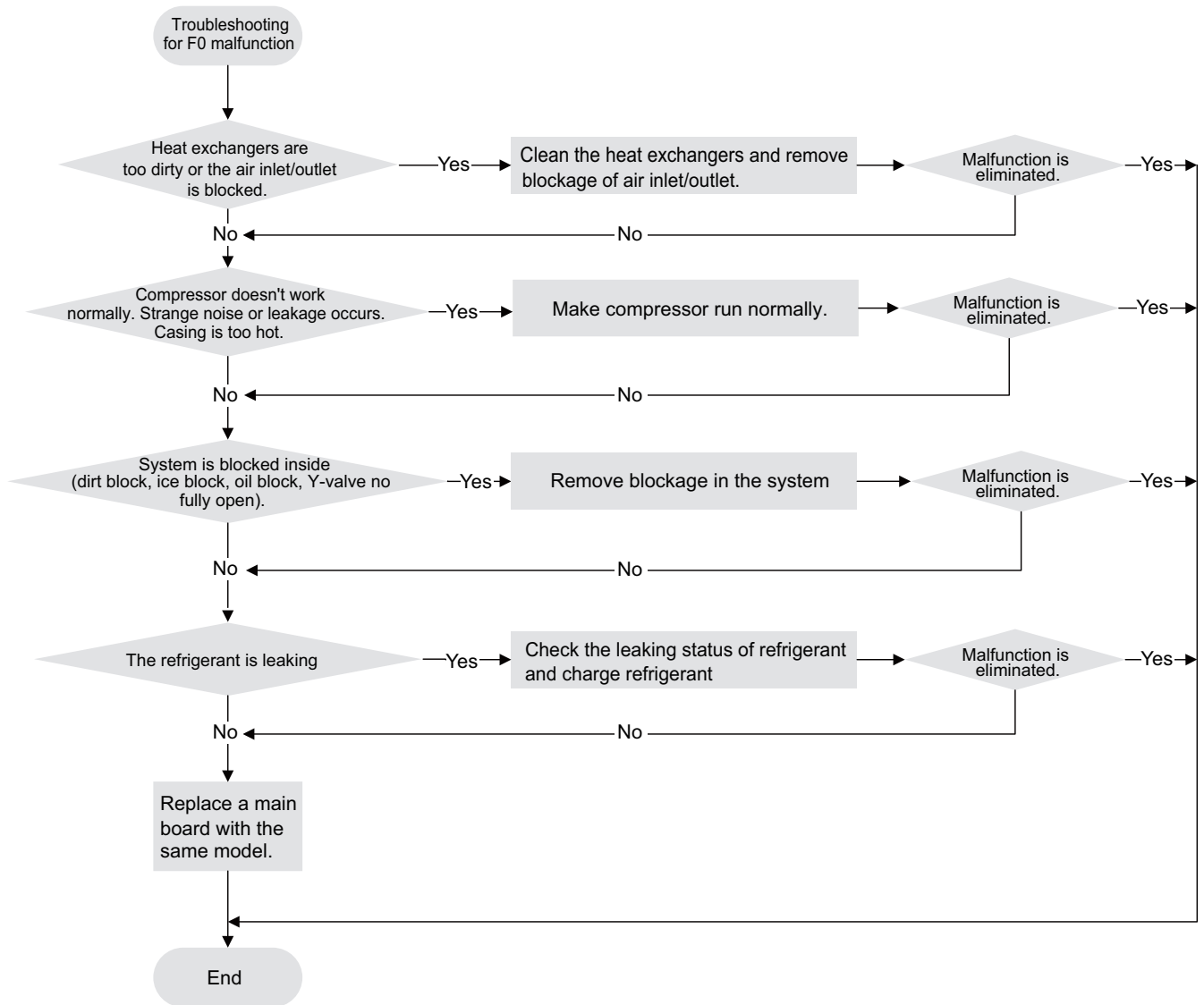

5. Malfunction of Blocked Protection of IDU Fan Motor H6

Main detection points:

- Smoothly is the control terminal of PG motor connected tightly?
- Smoothly is the feedback interface of PG motor connected tightly?
- The fan motor can't operate?
- The motor is broken?
- Detection circuit of the mainboard is defined abnormal?

Malfunction diagnosis process:

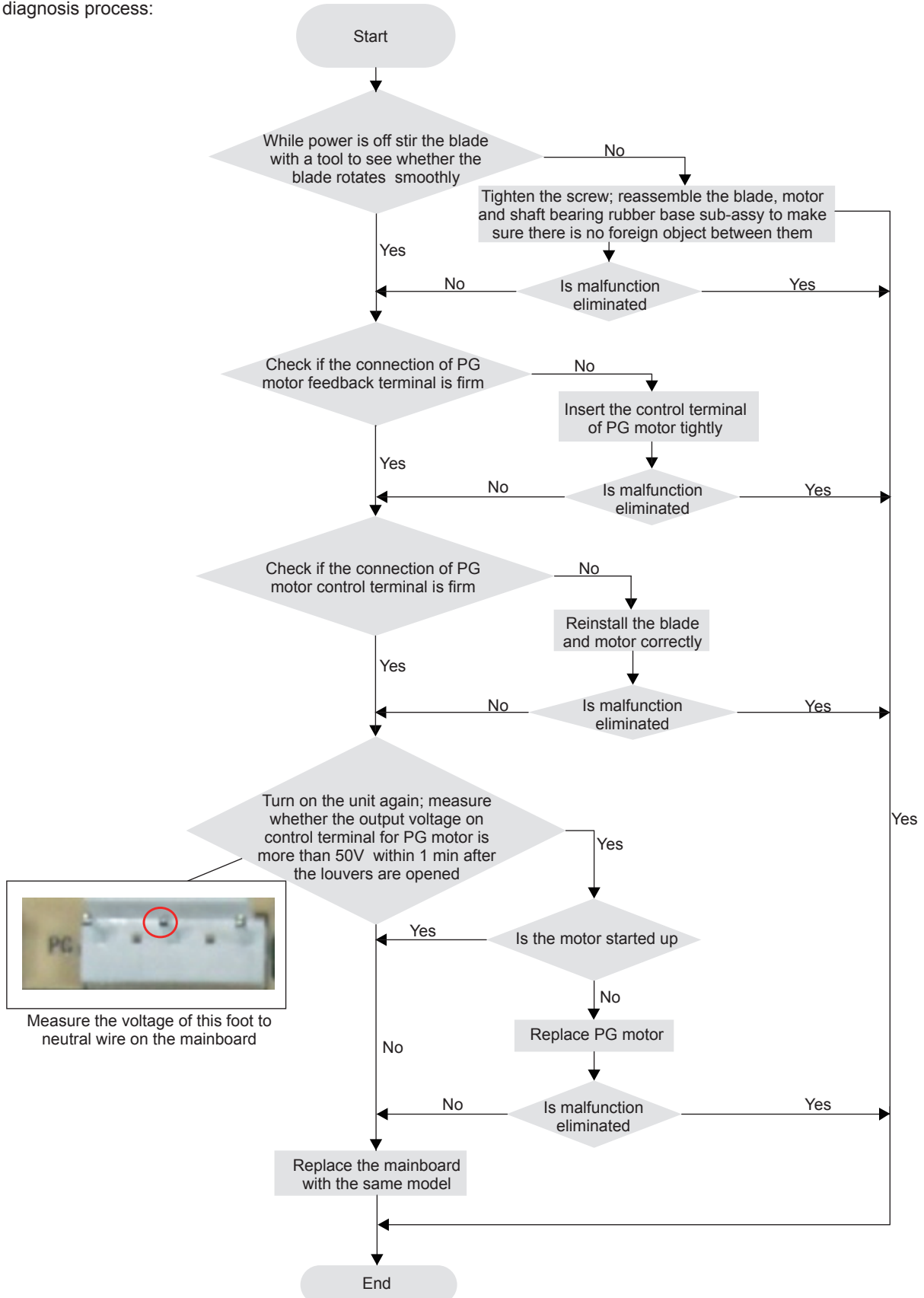

6. Malfunction of Protection of Jumper Cap C5

Main detection points:

- Is there jumper cap on the mainboard?
- Is the jumper cap inserted correctly and tightly?
- The jumper is broken?
- The motor is broken?
- Detection circuit of the mainboard is defined abnormal?

Malfunction diagnosis process:

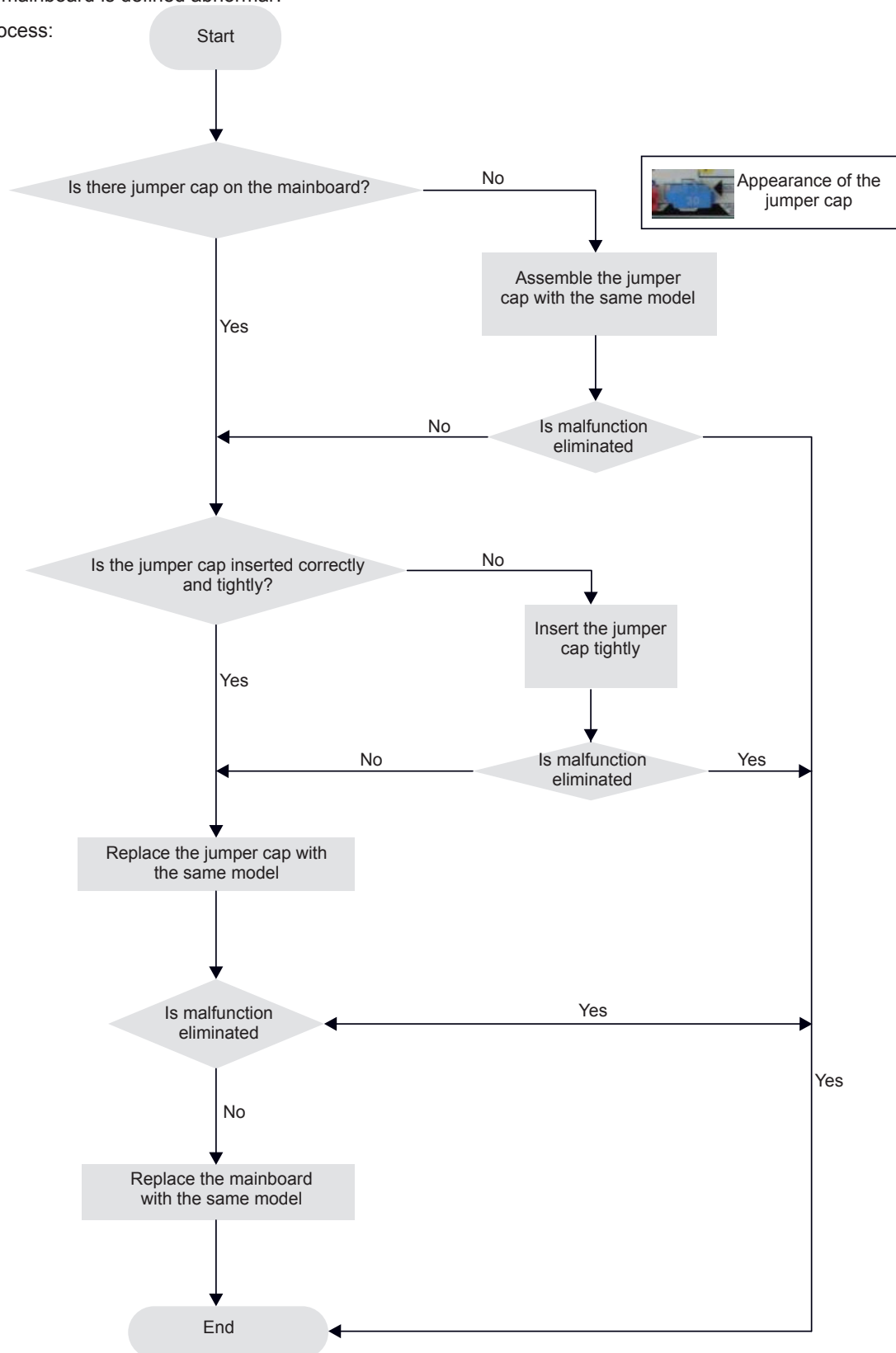

7. Malfunction of Zero-crossing Inspection Circuit Malfunction of the IDU Fan Motor U8

Main detection points:

- Instant energization after de-energization while the capacitor discharges slowly?
- The zero-cross detection circuit of the mainboard is defined abnormal?

Malfunction diagnosis process:

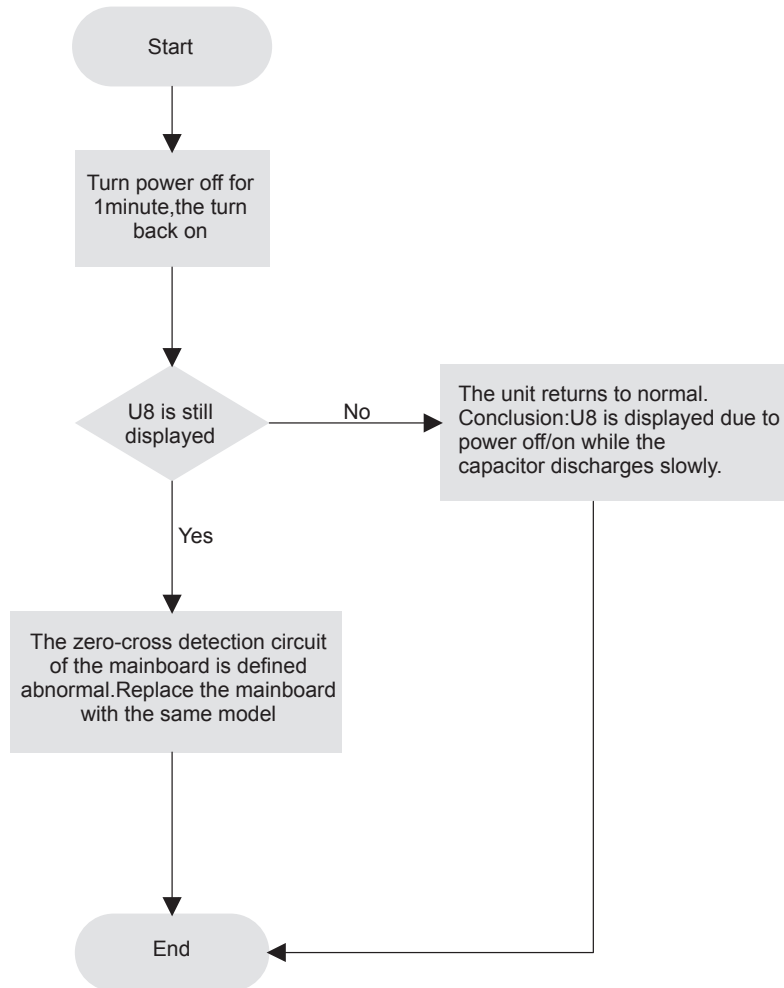

Outdoor Unit

1. Malfunction of Temperature Sensor (F3/F4/F5)

Main check point:

Whether the temperature sensor is damaged?

Whether the terminal of temperature sensor is loose or not connected?

Whether the main board is damaged?

Malfunction diagnosis process:

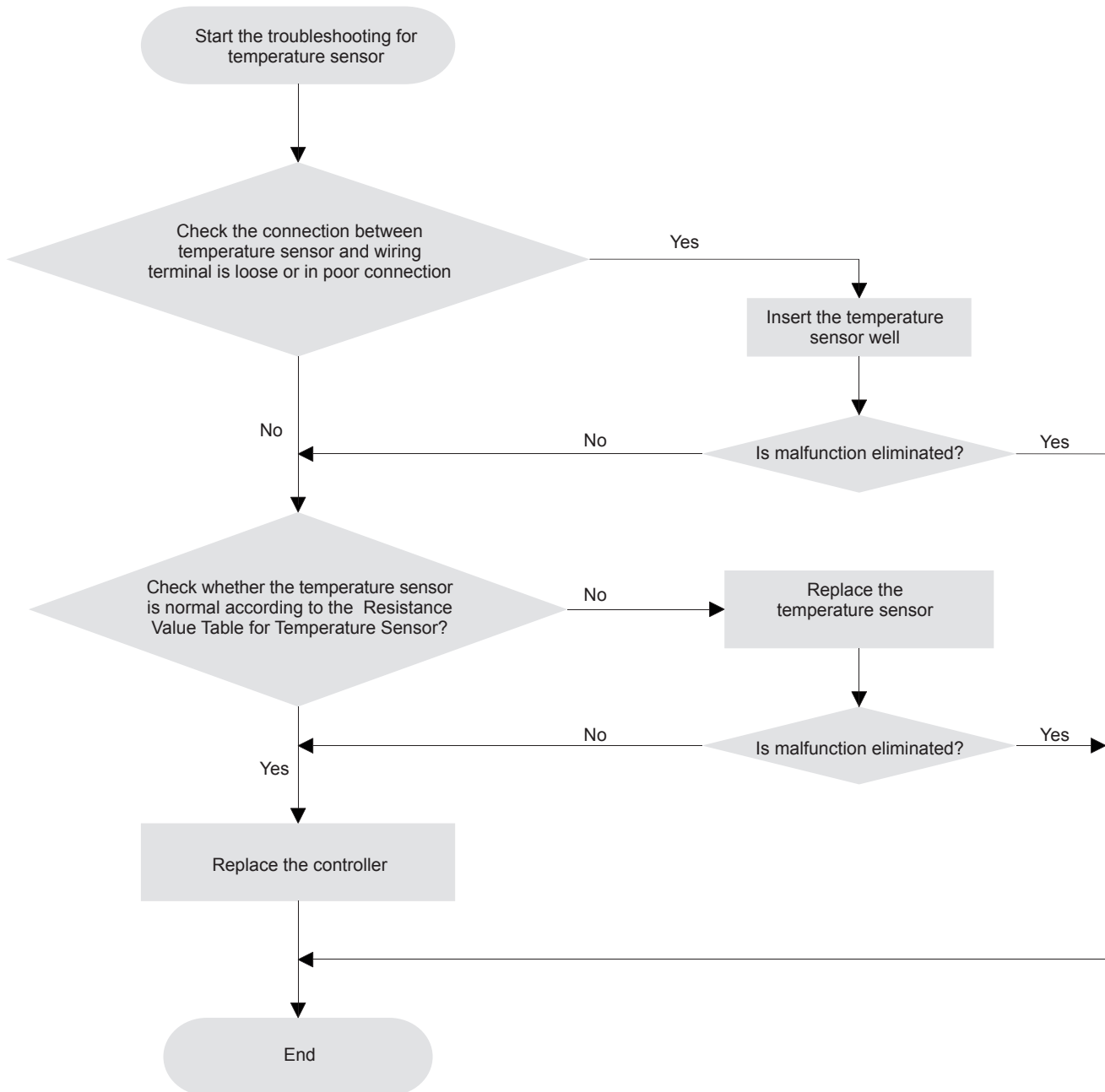

2. Malfunction of Overload Protection of Compressor (H3) and Discharge High-temperature Protection of Compressor (E4)

Main check point:

Whether the electronic expansion valve is connected well and whether its damaged?

Whether the refrigerant is leaking?

Whether the overload protector is damaged?

Malfunction diagnosis process:

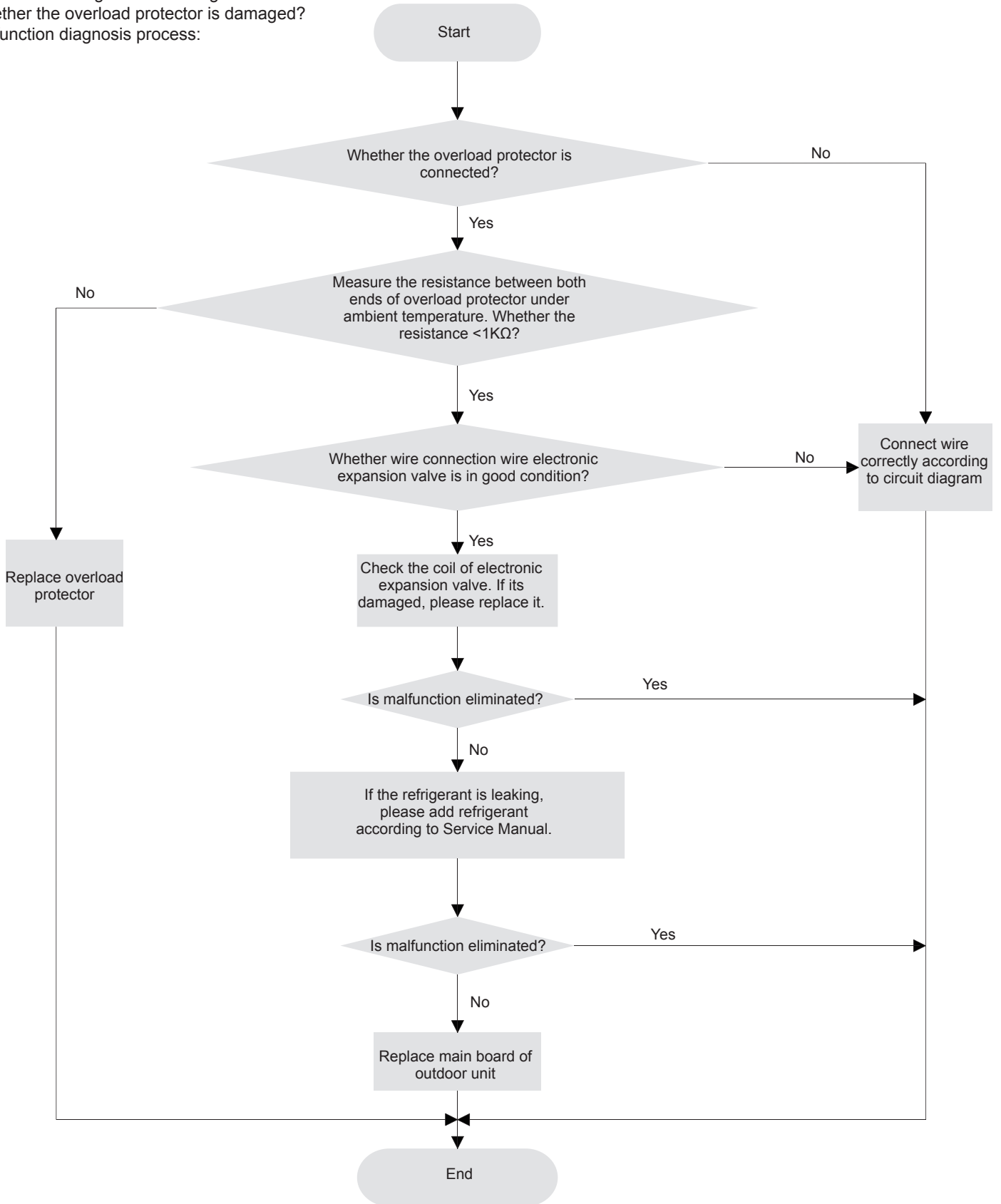

Remark:

Detection method for electronic expansion valve: There are 5 wires for the coil of electronic expansion valve and one of them are common port (the left or the right wire) .The resistance for other terminals are all most the same (about 100Ω). You can measure those resistance values to judge whether the electronic expansion valve is damaged or not.

3. Malfunction of Overload Protection (E8)

Main check point:

Whether the tube temperature sensor is normal?

Whether the outdoor ambient temperature is within the normal range?

Whether indoor fan and outdoor fan can operate normally?

Whether radiation environment inside or outside the unit is good?

Malfunction diagnosis process:

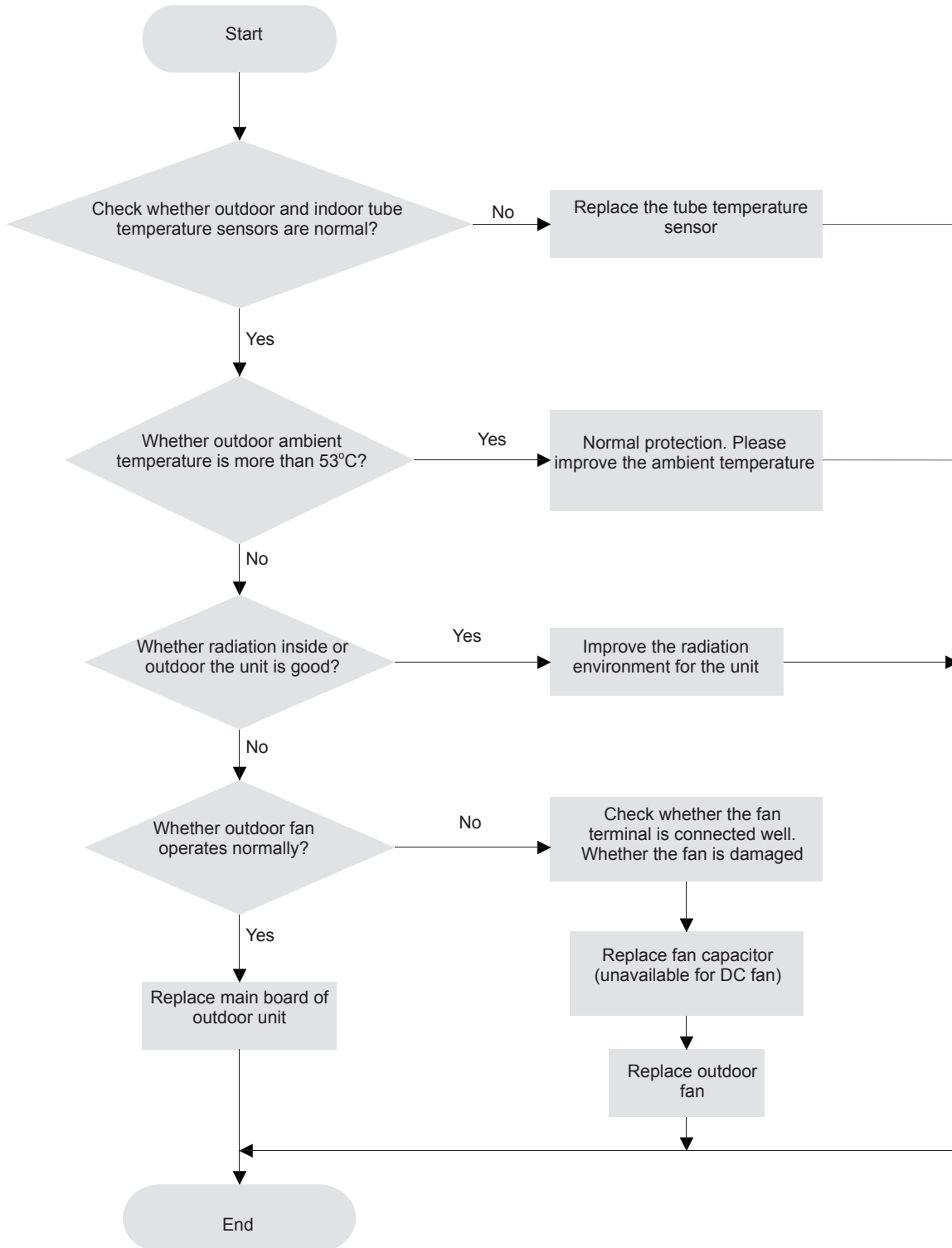

Remark:

When overload protection occurs under cooling mode, its because the main board detected the outdoor tube temperature sensor exceeds limited temperature and then the unit stops operation. Please check outdoor tube temperature sensor;

When overload protection occurs under heating mode, its because the main board detected the indoor tube temperature sensor exceeds limited temperature and then the unit stops operation. Please check indoor tube temperature sensor;

4. Malfunction of Overcurrent Protection E5

Main detection points:

- Is the supply voltage unstable with big fluctuation?
- Is the supply voltage too low with overload?
- Hardware trouble?

Malfunction diagnosis process:

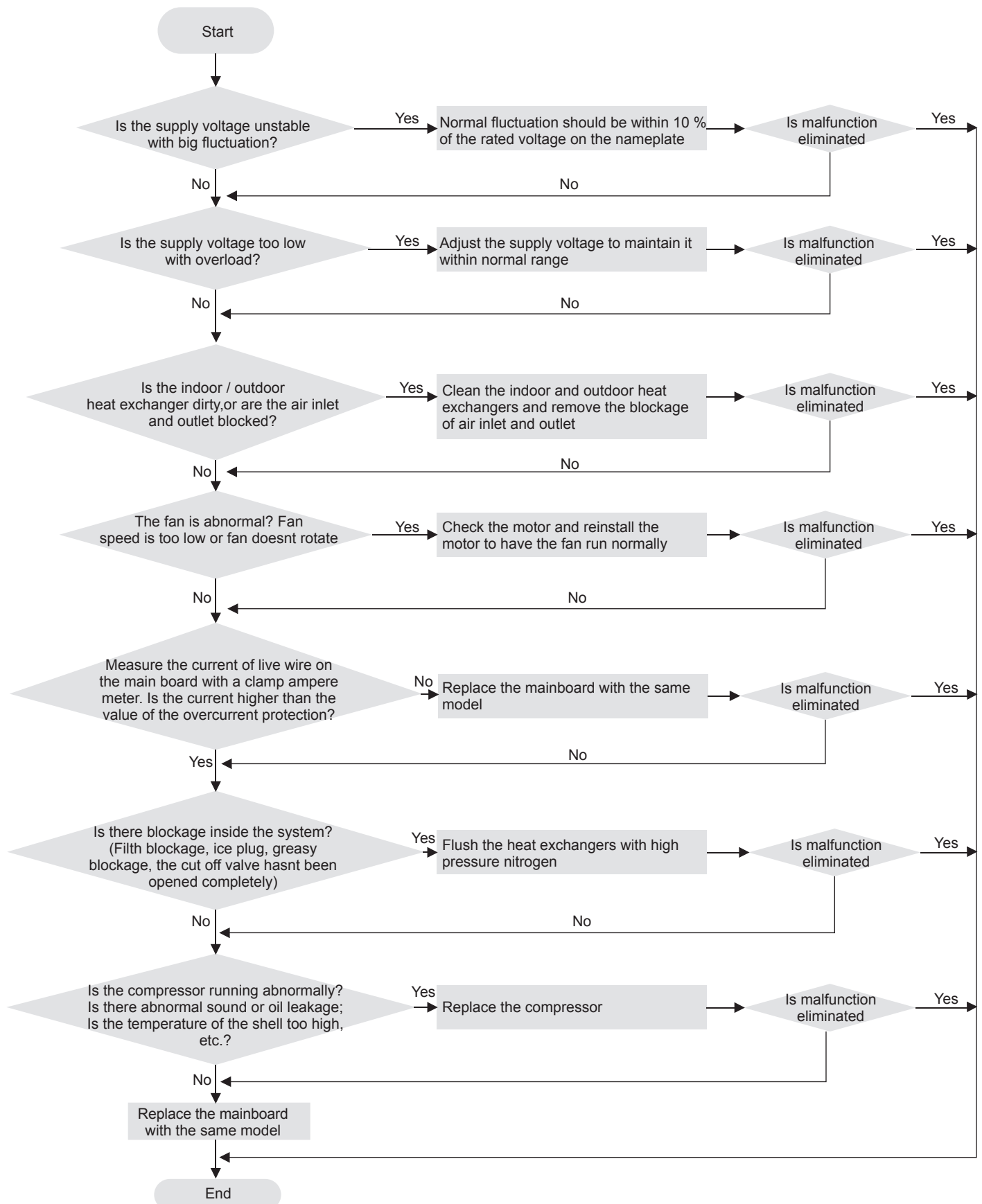

10. Exploded View and Parts List

GFH(09)CA-D6DNA1C/I GFH(12)CA-D6DNA1C/I

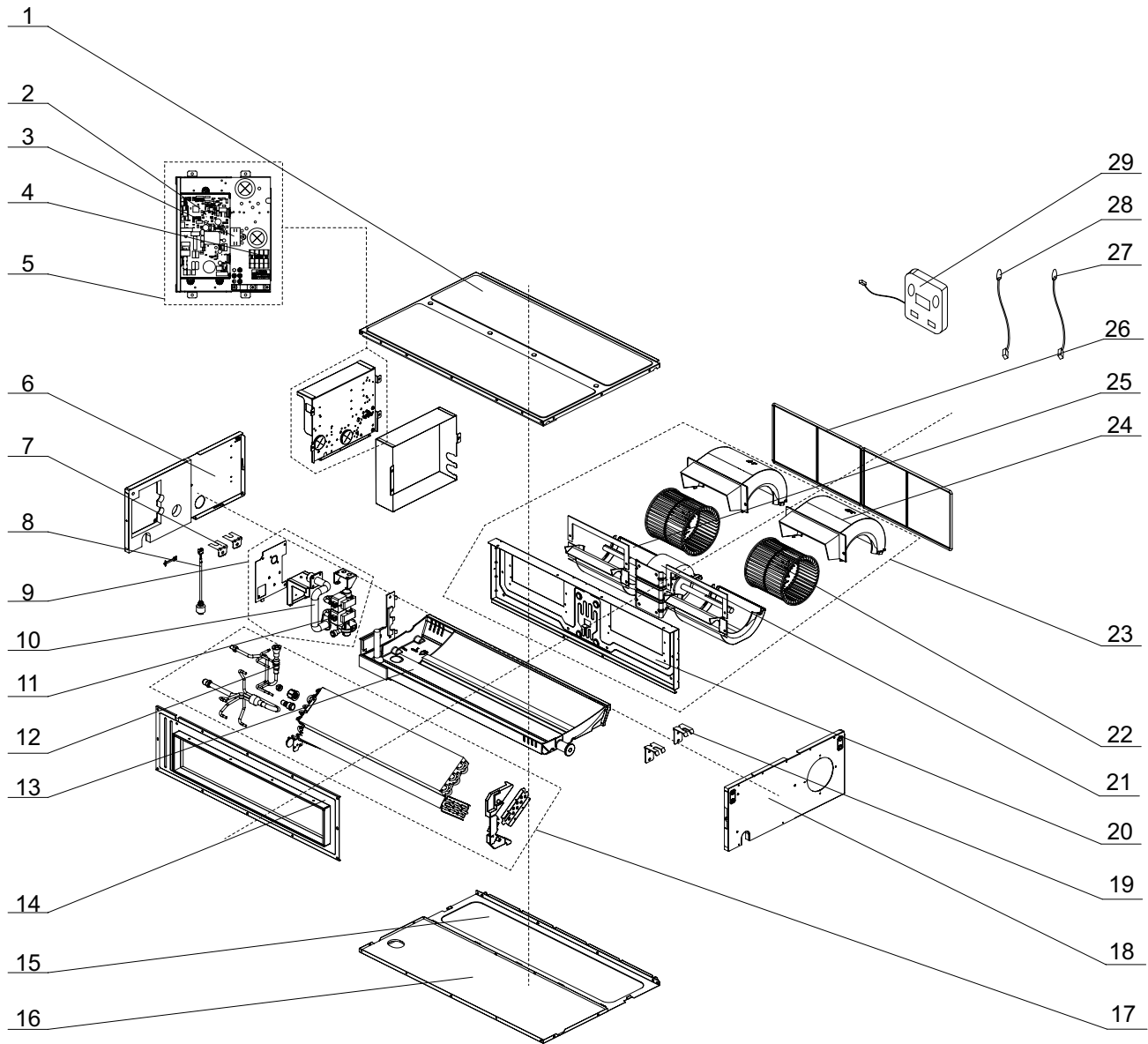

The component picture is only for reference; please refer to the actual product.

NO.	Description	NO.	Description
1	Top Cover Board Assy	16	Bottom Cover Plate Assy
2	Main Board	17	Evaporator Assy
3	Capacitor	18	Right Side Plate Assy
4	Terminal Board	19	Hook
5	Electric Box assy	20	Blower Mounting Plate Sub-Assy
6	Left Side Plate Assy	21	Fan Motor
7	Hook 2	22	Centrifugal fan
8	Liquid Level Switch	23	Centrifugal fan Assy
9	Water Pump Assy	24	Propeller Housing(Upper)
10	Drainage Pipe (Rubber)	25	Propeller Housing(Lower)
11	Water Pump	26	Filter Sub-Assy
12	Strainer	27	Temperature Sensor
13	Water Tray Assy	28	Ambient Temperature Sensor
14	Air Outlet Frame Assy	29	Display Board
15	Cover Plate(Air return)		

Some models may not contain some parts, please refer to the actual product.

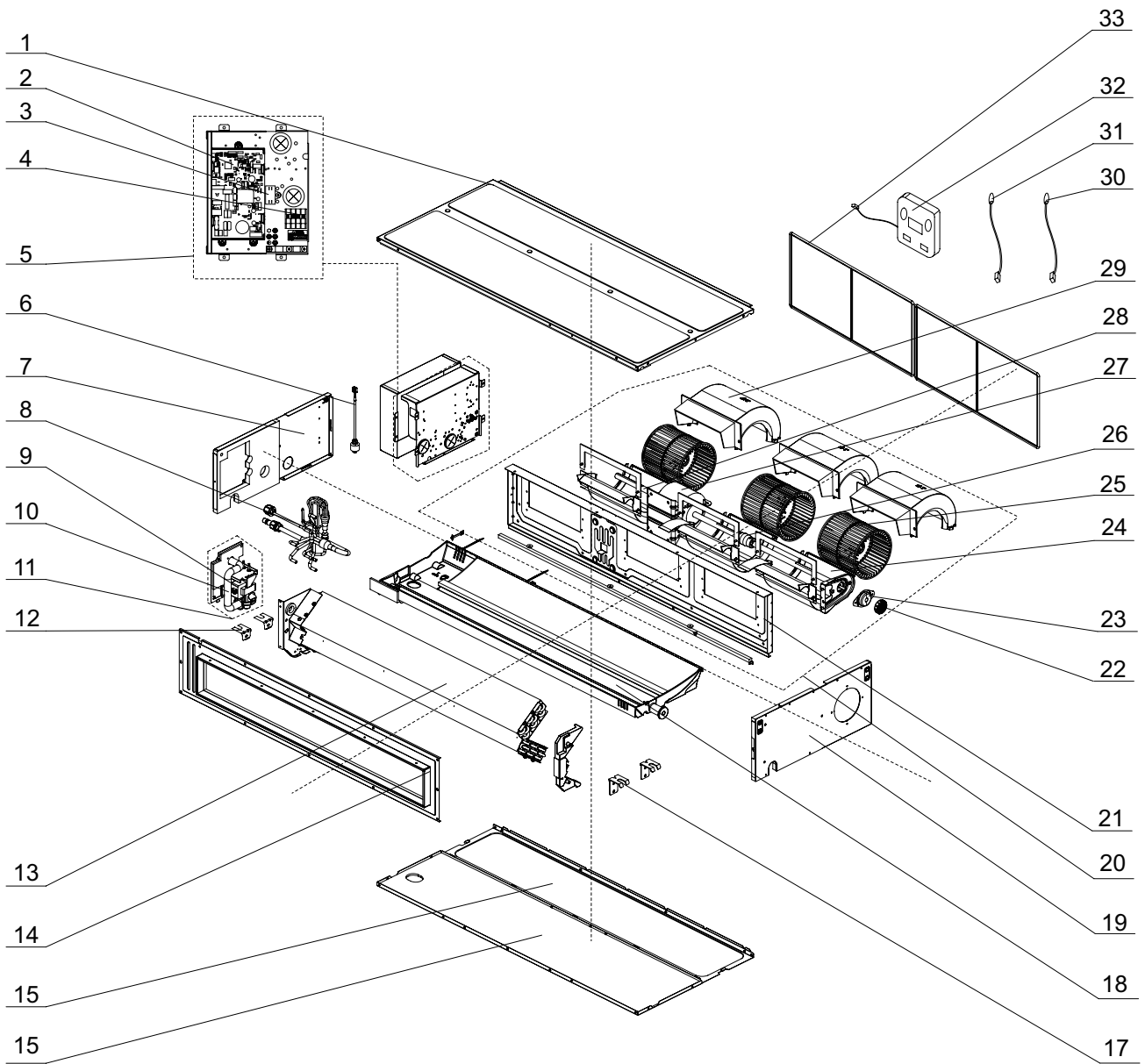

The component picture is only for reference; please refer to the actual product.

NO.	Description	NO.	Description
1	Top Cover Board Assy	18	Water Tray Assy
2	Main Board	19	Right Side Plate Assy
3	Capacitor	20	Centrifugal fan Assy
4	Terminal Board	21	Blower Mounting Plate Sub-Assy
5	Electric Box assy	22	Bearing Holder Sub-Assy
6	Liquid Level Switch	23	Support of Motor Motor
7	Left Side Plate Assy	24	Propeller Housing(Lower)
8	Strainer	25	Centrifugal fan
9	Water Pump	26	Joint Slack
10	Drainage Pipe (Rubber)	27	Fan Motor
11	Water Pump Assy	28	Rotary Axis Sub-Assy
12	Hook 2	29	Propeller Housing(Upper)
13	Evaporator Assy	30	Temperature Sensor
14	Air Outlet Frame Assy	31	Room Sensor
15	Cover of Air-In	32	Display Board
16	Bottom Cover Plate Assy	33	Filter Sub-Assy
17	Hook		

Some models may not contain some parts, please refer to the actual product.

11. Removal Procedure

 **Caution: discharge the refrigerant completely before removal.**

09/12K

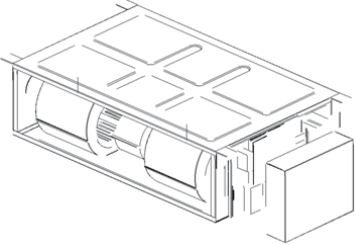
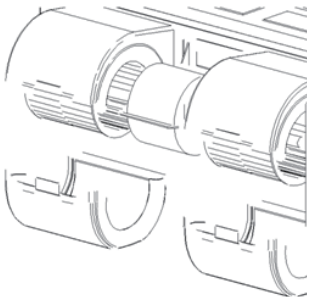
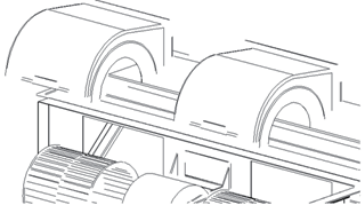
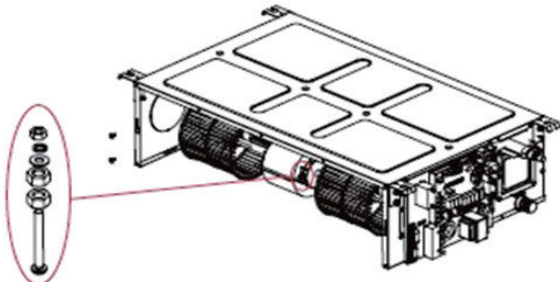
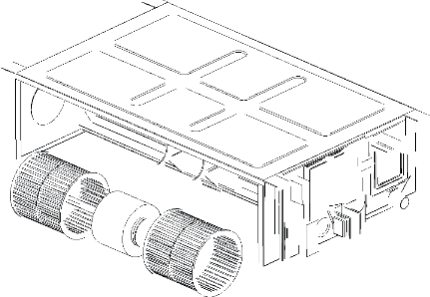
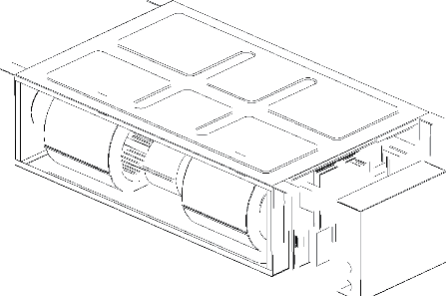
Step	Diagram	Operation Procedure
1. Remove the cover plate of the electric box.		<ul style="list-style-type: none"> ● Disconnect the power supply of the IDUs, use a screwdriver to unscrew the cover plate of the electric box, and then remove the line connecting to the motor.
2. Remove the rear volute casing.		<ul style="list-style-type: none"> ● Loosen the fasteners that connect the rear volute casing with the front volute casing and remove the rear volute casing.
3. Remove the front volute casing.		<ul style="list-style-type: none"> ● Use a screwdriver to unscrew the front volute casing and then remove the volute casing.
4. Remove the louver and motor.		<ul style="list-style-type: none"> ● Use a screwdriver to unscrew the louver and loosen the fasteners of the motor.
5. Install a new motor.		<ul style="list-style-type: none"> ● Remove the motor from the support and remove the louver from the motor. Then, remove the motor. ● Install a new motor.
6. Install units in a reverse order of this procedure.		<ul style="list-style-type: none"> ● Assemble units based on the reverse order of this procedure and power on the units for test.

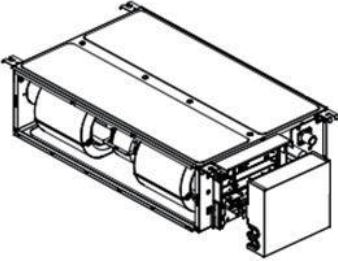
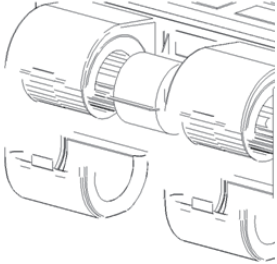
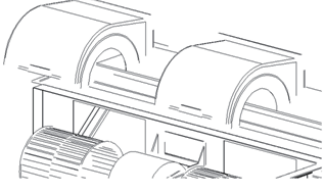
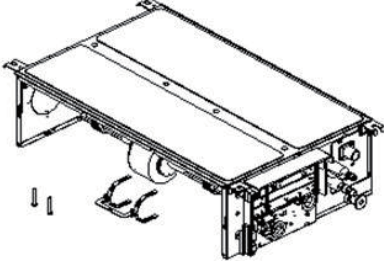
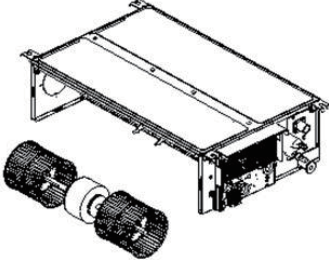
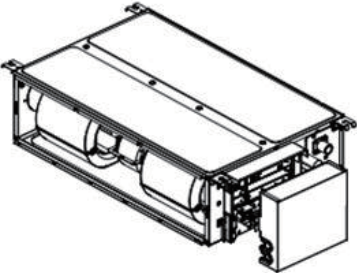
Step	Diagram	Operation Procedure
<p>1. Remove the air return filter.</p>		<ul style="list-style-type: none"> ● Draw the air return filter to both sides respectively at the return air inlet.
<p>2. Remove the cover plate of the electric box.</p>		<ul style="list-style-type: none"> ● Disconnect the power supply of the IDUs, use a screwdriver to unscrew the cover plate of the electric box, and then remove the line connecting to the motor.
<p>3. Remove the rear volute casing.</p>		<ul style="list-style-type: none"> ● Loosen the fasteners that connect the rear volute casing with the front volute casing and remove the rear volute casing.
<p>4. Remove the front volute casing.</p>		<ul style="list-style-type: none"> ● Use a screwdriver to unscrew the front volute casing and then remove the volute casing.
<p>5. Remove the louver and motor.</p>		<p>Use a screwdriver to unscrew the louver and loosen the fasteners of the motor.</p>
<p>6. Install a new motor.</p>		<ul style="list-style-type: none"> ● Remove the motor from the support and remove the louver from the motor. Then remove the motor. ● Install a new motor.
<p>7. Install units in a reverse order of this procedure.</p>		<ul style="list-style-type: none"> ● Assemble units based on the reverse order of this procedure and power on the units for test.



JF00305387



GREE ELECTRIC APPLIANCES, INC. OF ZHUHAI

Add: West Jinji Rd, Qianshan, Zhuhai, Guangdong, China, 519070

Tel: (+86-756) 8522219

Fax: (+86-756) 8669426

E-mail: global@cn.gree.com

For product improvement, specifications and appearance in this manual are subject to change without prior notice.