



Cassette Type Air Conditioner_R32

Service Manual

GREE ELECTRIC APPLIANCES, INC. OF ZHUHAI



Table of Contents

Part I : Technical Information	1
1. Summary.....	1
2. Specifications.....	3
3. Outline Dimension Diagram.....	10
4. Refrigerant System Diagram	12
5. Electrical Part	13
5.1 Wiring Diagram	13
5.2 PCB Printed Diagram.....	15
6. Function and Control	17
6.1 Remote Controller Introduction for YAP1F7(WiFi)	17
6.2 Remote Controller Introduction for YT1F(MOTO).....	22
6.3 Brief Description of Models and Functions	26
Part II : Installation and Maintenance	29
7. Notes for Installation and Maintenance.....	29
8. Installation	36
8.1 Outline of the Unit and Main Parts	36
8.2 Preparative for Installation	37
8.3 Installation Instructions	39
9. Maintenance	51
9.1 Error Code List.....	51
9.2 Procedure of Troubleshooting	58
9.3 Checkup.....	103
9.4 Troubleshooting for Normal Malfunction	107
10. Removal Procedure.....	112

Appendix 119
Appendix 1: Reference Sheet of Celsius and Fahrenheit..... 119
Appendix 2: Configuration of Connection Pipe 119
Appendix 3: Pipe Expanding Method..... 120
Appendix 4: List of Resistance for Temperature Sensor..... 121

1. Summary

Indoor Unit:

GKH(09)EB-D6DNA5A/I
GKH(12)EB-D6DNA5A/I
GKH(18)EB-D6DNA5A/I



GKH(24)EC-D6DNA6A/I

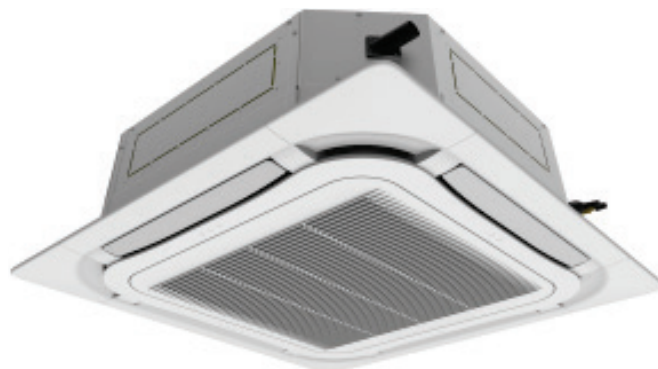

GKH(09)DA-D6DNA1A/I
GKH(12)DA-D6DNA1A/I
GKH(18)DA-D6DNA1A/I
GKH(20)DA-D6DNA1A/I



Remote Controller:



YAP1F7(WiFi)



YT1F(MOTO)

Model list:

No	Model	Product code	Indoor model	Indoor product code	Panel mode	Panel product code	Remote Controller
1	GKH(09)EB-D6DNA5A/I	CN51000360	GKH(09)EB-D6DNA5A/I	CN510N0360	TF05	TL10000230	YAP1F7 (WiFi)
2	GKH(12)EB-D6DNA5A/I	CN51000380	GKH(12)EB-D6DNA5A/I	CN510N0380	TF05	TL10000230	
3	GKH(18)EB-D6DNA5A/I	CN51000370	GKH(18)EB-D6DNA5A/I	CN510N0370	TF05	TL10000230	
4	GKH(24)EC-D6DNA6A/I	CN51000390	GKH(24)EC-D6DNA6A/I	CN510N0390	TF06	TL10000220	
5	GKH(09)DA-D6DNA1A/I	CN51000401	GKH(09)DA-D6DNA1A/I	CN510N0400	TD01	TL10000011	YT1F (MOTO)
6		CN5100040010				TL10000480	
7	GKH(12)DA-D6DNA1A/I	CN51000421	GKH(12)DA-D6DNA1A/I	CN510N0420		TL10000011	
8		CN5100042010				TL10000480	
9	GKH(18)DA-D6DNA1A/I	CN51000431	GKH(18)DA-D6DNA1A/I	CN510N0430		TL10000011	
10		CN5100043010				TL10000480	
11	GKH(20)DA-D6DNA1A/I	CN51000411	GKH(20)DA-D6DNA1A/I	CN510N0410		TL10000011	
12		CN5100041010				TL10000480	

2. Specifications

Specification Sheet

Model			GKH(09)EB-D6DNA5A/I
Product Code			CN51000360
Power Supply	Rated Voltage	V~	220
	Rated Frequency	Hz	60
	Phases	-	1
Cooling Capacity	KW		2.80
Heating Capacity	KW		2.80
Air flow volume	m ³ /h		560/540/490/450/420/380/350
Dehumidifying Volume	L/h		1.4
Fan Type			Centrifugal
Fan Diameter-height	mm		Φ315-162.5
Fan Motor Cooling Speed	rpm		700/660/600/560/520/480/440
Fan Motor Heating Speed	rpm		700/660/600/560/520/480/440
Fan Motor Power Output	W		30
Fan Motor Power Input	W		/
Fan motor running current	A		/
Fan Motor Capacitor	μF		/
Evaporator Material			Inner Groove Copper Tube-Aluminum fin
Evaporator Pipe Diameter	mm		Φ7
Evaporator Number of Rows-Fin Pitch	mm		2- 1.6
Evaporator Length(L)XHeight(H)XWidth(W)	mm		1176X228.6X25.4
Fuse Current	A		3.15
Sound Pressure Level	dB (A)		Cooling:41/39/36/34/32/30/28 Heating:40/38/36/34/32/30/28
Sound Power Level	dB (A)		57/55/52/50/48/46/44
Dimension of Outline(LXDXH)	mm		570X570X265
Dimension of Carton Box(LXWXH)	mm		695X650X280
Dimension of Package(LXWXH)	mm		698X653X295
Net Weight	kg		17.0
Gross Weight	kg		22.0
Liquid pipe	inch		1/4
Gas Pipe(to indoor unit)	inch		3/8
Panel mode			TF05
Panel product code			TL10000230
Panel Outline Dimension(LXDXH)	mm		620X620X47.5
Panel Dimension of Carton Box(LXWXH)	mm		698X698X110
Panel Package Dimension(LXWXH)	mm		701X701X125
Panel Net Weight	kg		3
Panel Gross Weight	kg		4.5

The above data is subject to change without notice. Please refer to the nameplate of the unit.

Model		GKH(12)EB-D6DNA5A/I	
Product Code		CN51000380	
Power Supply	Rated Voltage	V~	220
	Rated Frequency	Hz	60
	Phases	-	1
Cooling Capacity		KW	3.50
Heating Capacity		KW	4.00
Air flow volume		m ³ /h	560/540/490/450/420/380/350
Dehumidifying Volume		L/h	1.4
Fan Type		Centrifugal	
Fan Diameter-height		mm	Φ315-162.5
Fan Motor Cooling Speed		rpm	700/660/600/560/520/480/440
Fan Motor Heating Speed		rpm	700/660/600/560/520/480/440
Fan Motor Power Output		W	30
Fan Motor Power Input		W	/
Fan motor running current		A	/
Fan Motor Capacitor		μF	/
Evaporator Material		Inner Groove Copper Tube-Aluminum fin	
Evaporator Pipe Diameter		mm	Φ7
Evaporator Number of Rows-Fin Pitch		mm	2- 1.6
Evaporator Length(L)XHeight(H)XWidth(W)		mm	1176X228.6X25.4
Fuse Current		A	3.15
Sound Pressure Level		dB (A)	Cooling:41/39/36/34/32/30/28 Heating:40/38/36/34/32/30/28
Sound Power Level		dB (A)	57/55/52/50/48/46/44
Dimension of Outline(LXDXH)		mm	570X570X265
Dimension of Carton Box(LXWXH)		mm	695X650X280
Dimension of Package(LXWXH)		mm	698X653X295
Net Weight		kg	17.0
Gross Weight		kg	22.0
Liquid pipe		inch	1/4
Gas Pipe(to indoor unit)		inch	3/8
Panel mode		TF05	
Panel product code		TL10000230	
Panel Outline Dimension(LXDXH)		mm	620X620X47.5
Panel Dimension of Carton Box(LXWXH)		mm	698X698X110
Panel Package Dimension(LXWXH)		mm	701X701X125
Panel Net Weight		kg	3
Panel Gross Weight		kg	4.5

The above data is subject to change without notice. Please refer to the nameplate of the unit.

Model		GKH(18)EB-D6DNA5A/I
Product Code		CN51000370
Power Supply	Rated Voltage	V~ 220
	Rated Frequency	Hz 60
	Phases	- 1
Cooling Capacity	KW	5.00
Heating Capacity	KW	5.50
Air flow volume	m ³ /h	650/540/490/450/420/380/350
Dehumidifying Volume	L/h	1.8
Fan Type	-	Centrifugal
Fan Diameter-height	mm	Φ315-162.5
Fan Motor Cooling Speed	rpm	780/660/600/560/520/480/440
Fan Motor Heating Speed	rpm	780/660/600/560/520/480/440
Fan Motor Power Output	W	30
Fan Motor Power Input	W	/
Fan motor running current	A	/
Fan Motor Capacitor	μF	/
Evaporator Material	-	Inner Groove Copper Tube-Aluminum fin
Evaporator Pipe Diameter	mm	Φ7
Evaporator Number of Rows-Fin Pitch	mm	2- 1.6
Evaporator Length(L)XHeight(H)XWidth(W)	mm	1176X228.6X25.4
Fuse Current	A	3.15
Sound Pressure Level	dB (A)	Cooling:43/39/36/34/32/30/28 Heating:43/39/36/34/32/30/28
Sound Power Level	dB (A)	59/55/52/50/48/46/44
Dimension of Outline(LXDXH)	mm	570X570X265
Dimension of Carton Box(LXWXH)	mm	695X650X280
Dimension of Package(LXWXH)	mm	698X653X295
Net Weight	kg	17.0
Gross Weight	kg	22.0
Liquid pipe	inch	1/4
Gas Pipe(to indoor unit)	inch	1/2
Panel mode		TF05
Panel product code		TL10000230
Panel Outline Dimension(LXDXH)	mm	620X620X47.5
Panel Dimension of Carton Box(LXWXH)	mm	698X698X110
Panel Package Dimension(LXWXH)	mm	701X701X125
Panel Net Weight	kg	3
Panel Gross Weight	kg	4.5

The above data is subject to change without notice. Please refer to the nameplate of the unit.

Model		GKH(24)EC-D6DNA6A/I
Product Code		CN51000390
Power Supply	Rated Voltage	V~ 220
	Rated Frequency	Hz 60
	Phases	- 1
Cooling Capacity	KW	7.00
Heating Capacity	KW	8.00
Air flow volume	m ³ /h	1100/1050/950/910870//830/800
Dehumidifying Volume	L/h	2.5
Fan Type	-	Centrifugal
Fan Diameter-height	mm	Φ478.4-134
Fan Motor Cooling Speed	rpm	560/540/520/500/480/460/440
Fan Motor Heating Speed	rpm	560/540/520/500/480/460/440
Fan Motor Power Output	W	35
Fan Motor Power Input	W	/
Fan motor running current	A	/
Fan Motor Capacitor	μF	/
Evaporator Material	-	Inner Groove Copper Tube-Aluminum fin
Evaporator Pipe Diameter	mm	Φ7
Evaporator Number of Rows-Fin Pitch	mm	2- 1.6
Evaporator Length(L)XHeight(H)XWidth(W)	mm	2021X190.5X25.4
Fuse Current	A	5
Sound Pressure Level	dB (A)	Cooling:44/43/42/40/39/38/37 Heating:46/45/44/43/42/41/39
Sound Power Level	dB (A)	32/61/60/59/58/57/55
Dimension of Outline(LXDXH)	mm	840X840X240
Dimension of Carton Box(LXWXH)	mm	960X960X310
Dimension of Package(LXWXH)	mm	963X963X325
Net Weight	kg	29.0
Gross Weight	kg	36.0
Liquid pipe	inch	1/4
Gas Pipe(to indoor unit)	inch	5/8
Panel mode		TF06
Panel product code		TL10000220
Panel Outline Dimension(LXDXH)	mm	950X950X52
Panel Dimension of Carton Box(LXWXH)	mm	1030X1017X95
Panel Package Dimension(LXWXH)	mm	1033X1038X112
Panel Net Weight	kg	6
Panel Gross Weight	kg	9.5

The above data is subject to change without notice. Please refer to the nameplate of the unit.

Parameter		Unit	Value	
Model			GKH(09)DA-D6DNA1A/I	GKH(12)DA-D6DNA1A/I
Product Code			CN51000400 CN5100040010	CN51000421 CN5100042010
Power Supply	Rated Voltage	V~	220	220
	Rated Frequency	Hz	60	60
	Phases		1	1
Cooling Capacity		KW	2.6	3.5
Heating Capacity		KW	2.8	3.6
Cooling Power Input		KW	0.03	0.03
Heating Power Input		KW	0.03	0.03
Rated Current		A	0.2	0.2
Air flow volume		m ³ /h	550/450/390/340/-	600/500/440/390/-
Dehumidifying Volume		L/h	0.8	1.4
Fan Type			Cross-flow	Cross-flow
Fan Diameter-height		mm	Φ107-778	Φ107-778
Fan Motor Cooling Speed		rpm	1000/900/820/750	1150/1000/850/770
Fan Motor Heating Speed		rpm	1000/900/820/750	1150/1000/850/770
Fan Motor Power Output		W	30	30
Fan motor running current		A	0.2	0.2
Fan Motor Capacitor		μF	/	/
Evaporator Material			Aluminum fin-copper tube	Aluminum fin-copper tube
Evaporator Pipe Diameter		mm	Φ7	Φ7
Evaporator Number of Rows-Fin Pitch		mm	2-1.6	2-1.6
Evaporator Length(L)XHeight(H)XWidth(W)		mm	2(790X25.4X114.3)	2(790X25.4X114.3)
Fuse Current		A	5	5
Sound Pressure Level		dB (A)	39/36/33/31/-	42/39/35/31/-
Sound Power Level		dB (A)	49/46/43/41/-	53/50/43/41/-
Dimension of Outline(LXWXH)		mm	987X385X178	987X385X178
Dimension of Carton Box(LXWXH)		mm	1304X498X295	1304X498X295
Dimension of Package(LXWXH)		mm	1307X501X310	1307X501X310
Net Weight		kg	19	19
Gross Weight		kg	26	26
Liquid pipe		inch	1/4	1/4
Gas Pipe(to indoor unit)		inch	3/8	3/8
Panel mode			TD01	TD01
Panel product code			TL10000011/TL10000480	TL10000011/TL10000480
Panel Outline Dimension(LXDXH)		mm	1200X460X55	1200X460X55
Panel Dimension of Carton Box(LXWXH)		mm	1262X533X106	1262X533X106
Panel Package Dimension(LXWXH)		mm	1265X536X121	1265X536X121
Panel Net Weight		kg	4.2	4.2
Panel Gross Weight		kg	6	6

The above data is subject to change without notice. Please refer to the nameplate of the unit.

Parameter		Unit	Value	
Model			GKH(18)DA-D6DNA1A/I	GKH(20)DA-D6DNA1A/I
Product Code			CN51000431 CN5100043010	CN51000411 CN5100041010
Power Supply	Rated Voltage	V~	220	220
	Rated Frequency	Hz	60	60
	Phases		1	1
Cooling Capacity		KW	5.0	5.6
Heating Capacity		KW	5.3	6.0
Cooling Power Input		KW	0.05	0.05
Heating Power Input		KW	0.05	0.05
Rated Current		A	0.3	0.3
Air flow volume		m ³ /h	700/600/500/450/-	750/650/550/500/-
Dehumidifying Volume		L/h	1.8	2.0
Fan Type			Cross-flow	Cross-flow
Fan Diameter-height		mm	Φ107-778	Φ107-778
Fan Motor Cooling Speed		rpm	1250/1100/900/850	1330/1180/1030/900
Fan Motor Heating Speed		rpm	1250/1100/900/850	1330/1180/1030/900
Fan Motor Power Output		W	30	30
Fan motor running current		A	0.3	0.3
Fan Motor Capacitor		μF	/	/
Evaporator Material			Aluminum fin-copper tube	Aluminum fin-copper tube
Evaporator Pipe Diameter		mm	Φ7	Φ7
Evaporator Number of Rows-Fin Pitch		mm	2-1.6	2-1.6
Evaporator Length(L)XHeight(H)XWidth(W)		mm	790X25.4X114.3 790X38.1X114.3	790X25.4X114.3 790X38.1X114.3
Fuse Current		A	5	5
Sound Pressure Level		dB (A)	43/40/35/32/-	46/43/40/36/-
Sound Power Level		dB (A)	56/53/48/45/-	58/55/52/48/-
Dimension of Outline(LXWXH)		mm	987X385X178	987X385X178
Dimension of Carton Box(LXWXH)		mm	1304X498X295	1304X498X295
Dimension of Package(LXWXH)		mm	1307X501X310	1307X501X310
Net Weight		kg	20	20
Gross Weight		kg	27	27
Liquid pipe		inch	1/4	1/4
Gas Pipe(to indoor unit)		inch	1/2	1/2
Panel mode			TD01	TD01
Panel product code			TL10000011/TL10000480	TL10000011/TL10000480
Panel Outline Dimension(LXDXH)		mm	1200X460X55	1200X460X55
Panel Dimension of Carton Box(LXWXH)		mm	1262X533X106	1262X533X106
Panel Package Dimension(LXWXH)		mm	1265X536X121	1265X536X121
Panel Net Weight		kg	4.2	4.2
Panel Gross Weight		kg	6	6

The above data is subject to change without notice. Please refer to the nameplate of the unit.

Note: Nominal capacities are based on the follow conditions.

Mode	Indoor °C(°F)	Outdoor °C(°F)
Cooling	DB:27 (80.6)	DB:35(95)
	WB:19 (66.2)	WB:24(75.2)
Heating	DB:20 (68)	DB:7(44.6)
	WB:--(--)	WB:6 (42.8)
Piping Length	5m	

The air volume is measured at the relevant standard external static pressure.

Noise is tested in the semianechoic room, so it should be slightly higher in the actual operation due to environmental change.

3. Outline Dimension Diagram

GKH(09)EB-D6DNA5A/I GKH(12)EB-D6DNA5A/I GKH(18)EB-D6DNA5A/I

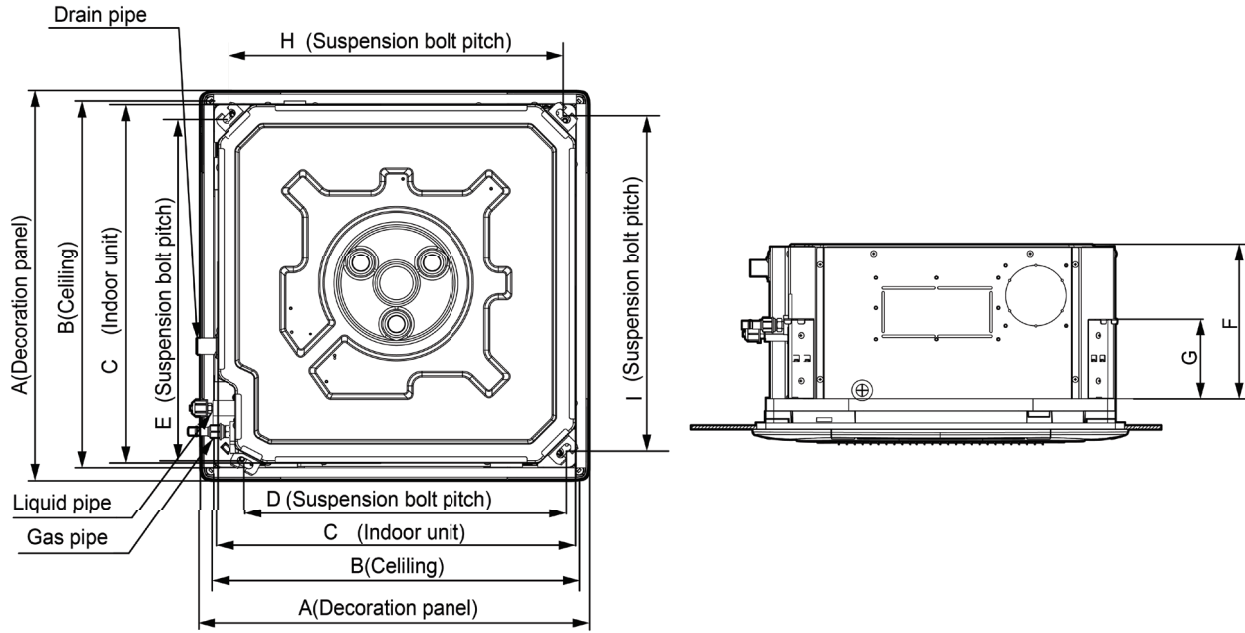

Unit: mm

Model	A	B	C	D	E	F	G	H	I
GKH(09)EB-D6DNA5A/I	620	580	570	505	550	265	140	530	530
GKH(12)EB-D6DNA5A/I	620	580	570	505	550	265	140	530	530
GKH(18)EB-D6DNA5A/I	620	580	570	505	550	265	140	530	530

GKH(24)EC-D6DNA6A/I

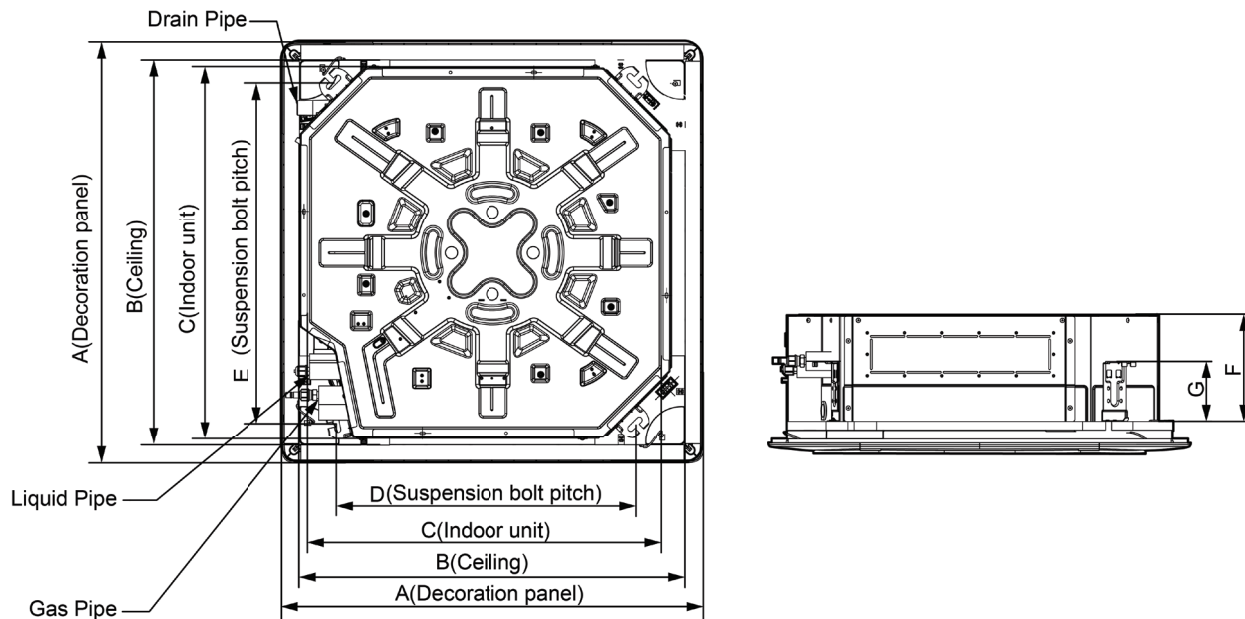

Unit: mm

Model	A	B	C	D	E	F	G
GKH(24)EC-D6DNA6A/I	950	870	840	680	780	240	135

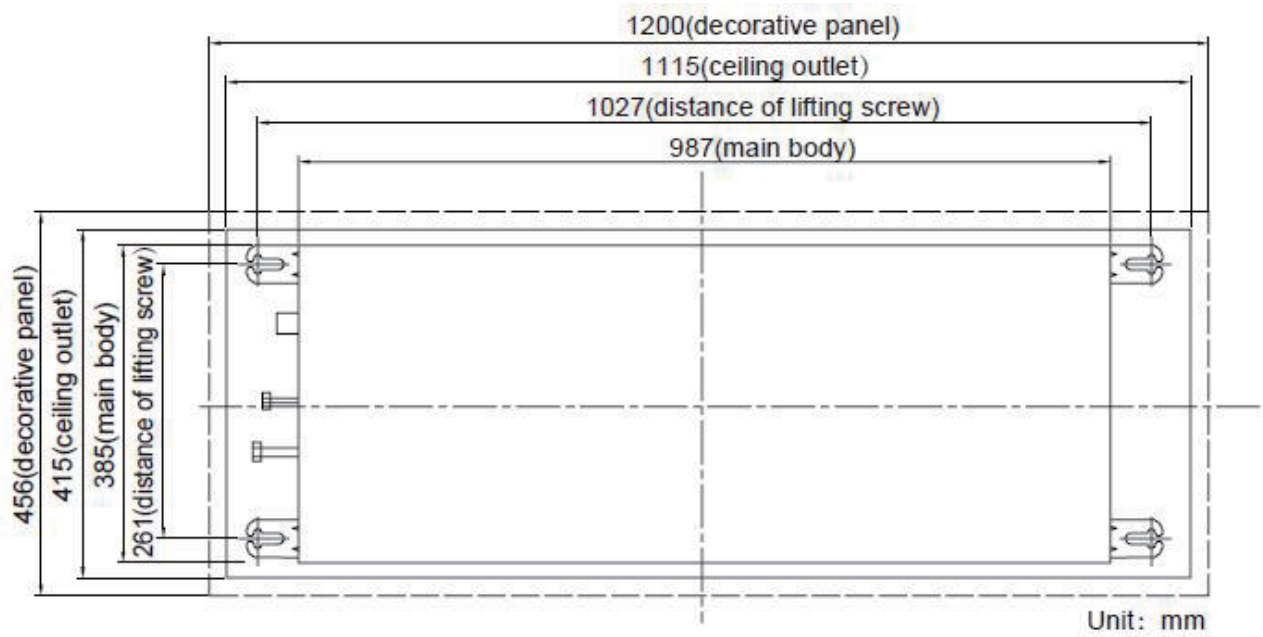

4. Refrigerant System Diagram

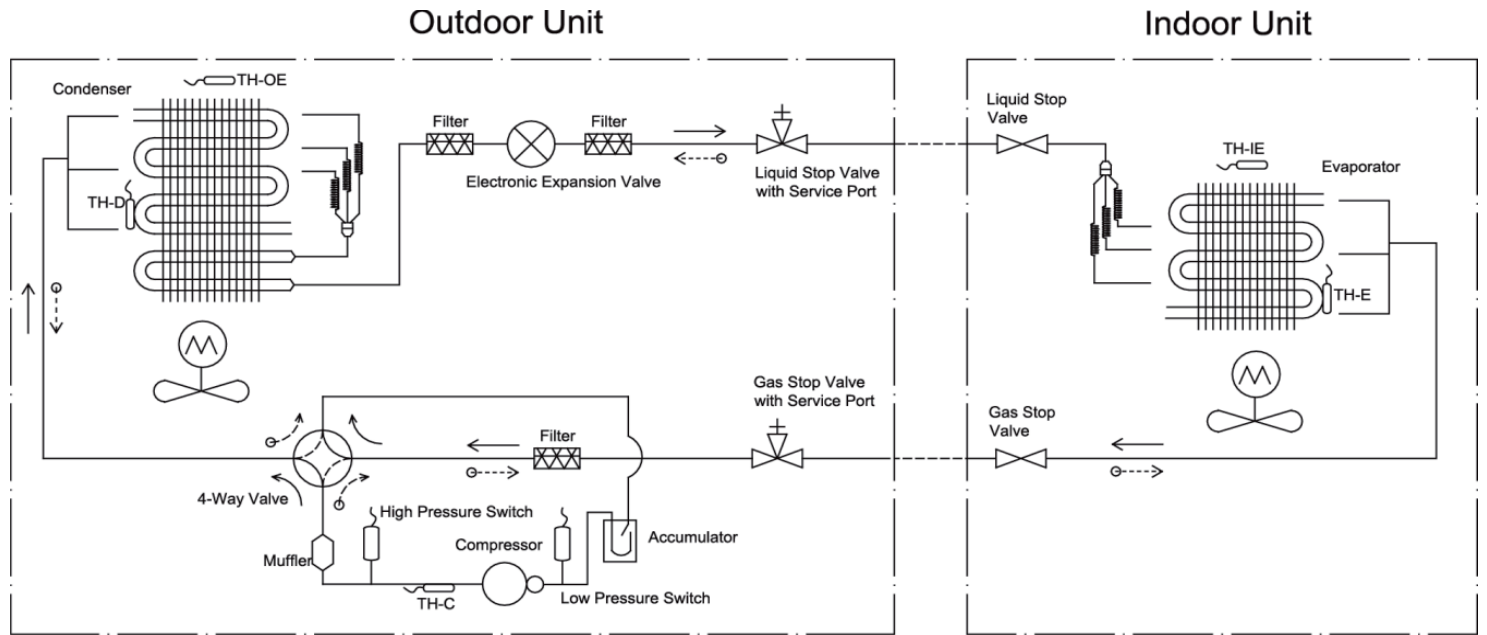

TH-OE: Outdoor Environment Thermal Bulb
 TH-C: Outdoor Condenser Thermal Bulb
 TH-D: Compressor Discharge Thermal Bulb

← Cooling
 ⤵ Heating

TH-IE: Indoor Environment Thermal Bulb
 TH-E: Indoor Evaporator Thermal Bulb

Note:

1. it is just a schematic diagram and some parts may differ from the real objects inside the unit.

5. Electrical Part

5.1 Wiring Diagram

•Instruction

Symbol	Symbol Color	Symbol	Symbol Color	Symbol	Name
WH	White	GN	Green	CAP	Jumper cap
YE	Yellow	BN	Brown	COMP	Compressor
RD	Red	BU	Blue		Grounding wire
YEGN	Yellow/Green	BK	Black	GY	Gary
VT	Violet	OG	Orange	/	/

Note: Jumper cap is used to determine fan speed and the swing angle of horizontal lover for this model.

GKH(09)EB-D6DNA5A/I GKH(12)EB-D6DNA5A/I GKH(18)EB-D6DNA5A/I

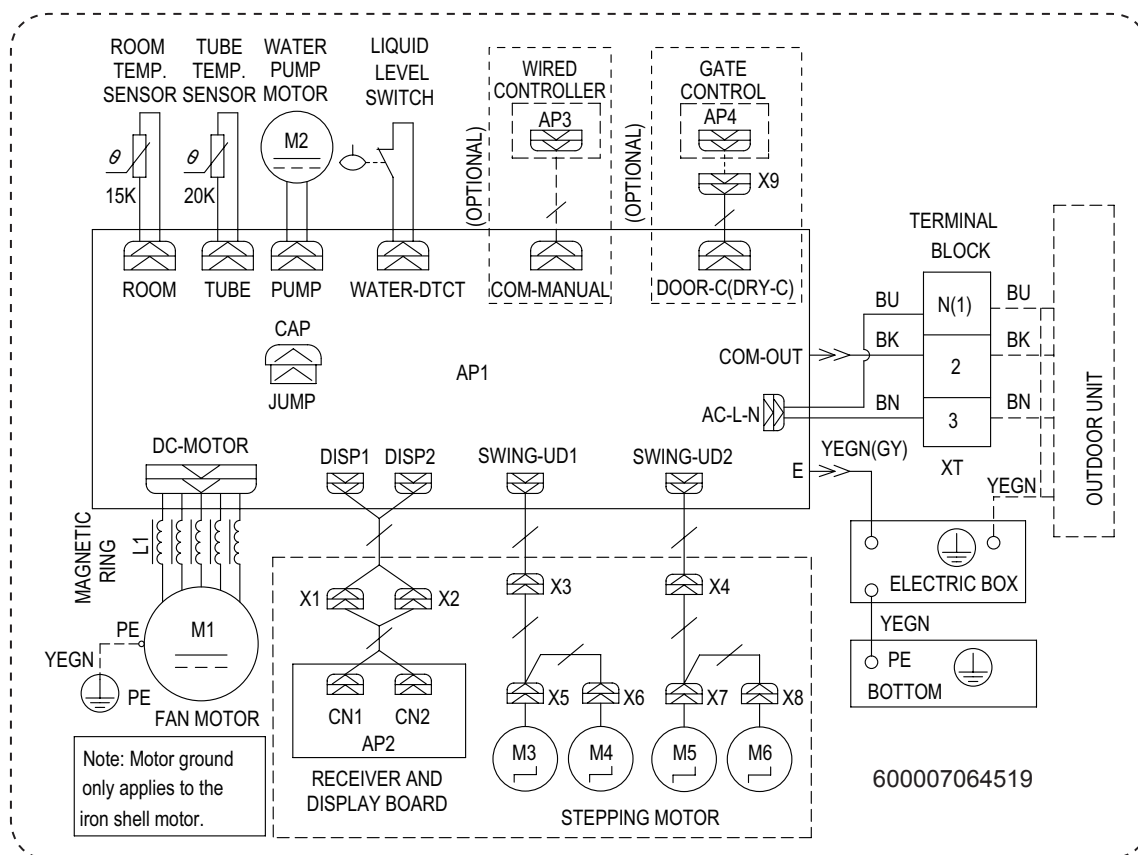

5.2 PCB Printed Diagram

GKH(09)EB-D6DNA5A/I GKH(12)EB-D6DNA5A/I GKH(18)EB-D6DNA5A/I

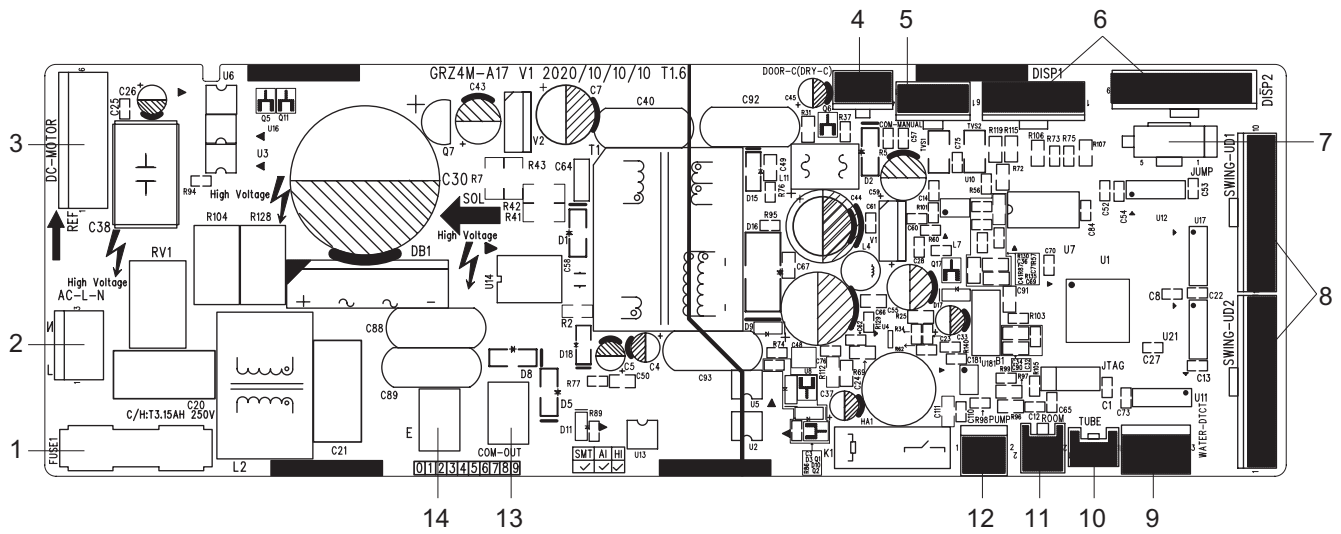

No.	Name
1	Fuse
2	Interface of live and neutral wire
3	Interface of fan
4	Interface of gate-control detection
5	Wired controller
6	Display interface
7	Jump cap

No.	Name
8	Up&down swing terminal
9	Water full detection terminal
10	Interface of tube temperature sensor
11	Interface of ambient temperature sensor
12	Water pump control
13	Terminal with outdoor unit communication wire
14	Ground wire interface

6. Function and Control

6.1 Remote Controller Introduction for YAP1F7(WiFi)

NOTE:

- This is a general use remote controller. It could be used for the air conditioner with multifunction. For the functions which the model doesn't have, if press the corresponding button on the remote controller, the unit will keep the original running status.
- After putting through the power, the air conditioner will give out a sound. Operation indicator "U" is ON. After that, you can operate the air conditioner by using remote controller.
- Under on status, pressing the button on the remote controller, the signal icon "W" on the display of remote controller will blink once and the air conditioner will give out a "di" sound, which means the signal has been sent to the air conditioner.
- As for the models with functions of WiFi or wired controller, the indoor unit must has been controlled by standard remote controller under auto mode first, and then the function of adjustable temperature under auto mode can be realized by APP or the wired controller.
- This remote controller can adjust the temperature under auto mode. When matching with the unit which is without the function of adjustable temperature under auto mode, the set temperature under auto mode may be invalid, or the displayed set temperature on the unit is not same as that on the remote controller under auto mode.

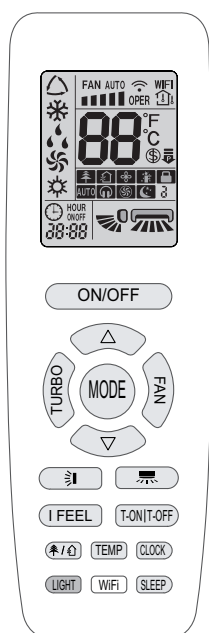

ON/OFF

Press this button to turn on the unit. Press this button again to turn off the unit.

MODE

Press this button to select your required operation mode.



- When selecting auto mode, air conditioner will operate automatically according to ex-factory setting. Press "FAN" button can adjust fan speed. Press "扇" / "↗" button can adjust fan blowing angle.

- After selecting cool mode, air conditioner will operate under cool mode. Press "△" or "▽" button to adjust set temperature. Press "FAN" button to adjust fan speed. Press "扇" / "↗" button to adjust fan blowing angle.

- When selecting dry mode, the air conditioner operates at low speed under dry mode. Under dry mode, fan speed can't be adjusted. Press "扇" / "↗" button to adjust fan blowing angle.

- When selecting fan mode, the air conditioner will only blow fan, no cooling and no heating. All indicators are OFF. Press "FAN" button to adjust fan speed. Press "扇" / "↗" button to adjust fan blowing angle.

- When selecting heating mode, the air conditioner operates under heat mode. Press "△" or "▽" button to adjust set temperature. Press "FAN" button to adjust fan speed. Press "扇" / "↗" button to adjust fan blowing angle. (Cooling only unit won't receive heating mode signal. If setting heat mode with remote controller, press ON/OFF button can't start up the unit).

NOTE:

- For preventing cold air, after starting up heating mode, indoor unit will delay 1~5 minutes to blow air (actual delay time is depend on indoor ambient temperature).

Introduction for icons on display screen

	I feel	
	Set fan speed	
	Turbo mode	
	Send signal	
Operation mode		Auto mode
		Cool mode
		Dry mode
		Fan mode
		Heat mode
	Sleep mode	
	8°C heating function	
	Power limiting operation	
	Health mode	
	Scavenging function	
	X-FAN function	
Temp. display type		Set temp.
		Indoor ambient temp.
		Outdoor ambient temp.
	Clock	
	Set temperature	
	WiFi function	
	Set time	
	TIMER ON / TIMER OFF	
	Left & right swing	
	Up & down swing	
	Child lock	
	Quiet	

- Set temperature range from remote controller: 16~30°C (61~86 °F).
- Under auto mode, temperature can be displayed; Under auto mode, set temperature can be adjusted.
- This mode indicator is not available for some models.



This button is used for setting Fan Speed in the sequence that goes from AUTO, , , , , to , then back to Auto.

NOTE:

- Under AUTO speed, air conditioner will select proper fan speed automatically according to factory default setting.
- It's low fan speed under dry mode.
- X-FAN function: Holding fan speed button for 2s in cool or dry mode, the icon " " is displayed and the indoor fan will continue operation for a few minutes in order to dry the indoor unit even though you have turned off the unit. After energization, X-FAN OFF is defaulted. X-FAN is not available in auto, fan or heat mode.

This function indicates that moisture on evaporator of indoor unit will be blown after the unit is stopped to avoid mould.

- Having set X-FAN function on: After turning off the unit by pressing ON/OFF button, indoor fan will continue running for a few minutes at low speed. In this period, hold fan speed button for 2s to stop indoor fan directly.

Having set X-FAN function off: After turning off the unit by pressing ON/OFF button, the complete unit will be off directly.



Under COOL or HEAT mode, press this button to turn to quick COOL or quick HEAT mode. " " icon is displayed on remote controller. Press this button again to exit turbo function and " " icon will disappear. If start this function, the unit will run at super-high fan speed to cool or heat quickly so that the ambient temp. approaches the preset temp. as soon as possible.



- Press "△" or "▽" button once increase or decrease set temperature 1°C (°F). Holding "△" or "▽" button, 2s later, set temperature on remote controller will change quickly. On releasing button after setting is finished, temperature indicator on indoor unit will change accordingly.
- When setting T-ON, T-OFF or CLOCK, press "△" or "▽" button to adjust time. (Refer to CLOCK, TON, T-OFF buttons)



Press this button can select left & right swing angle. Fan blow angle can be selected circularly as below:

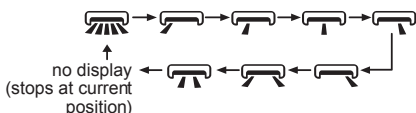

NOTE:

- Press this button continuously more than 2s, the main unit will swing back and forth from left to right, and then loosen the button, the unit will stop swinging and present position of guide louver will be kept immediately.
- Under left and right swing mode, when the status is switched from off to , if press this button again 2s later, status will switch to off status directly; if press this button again within 2s, the change of swing status will also depend on the circulation sequence stated above.
- The function is only available for some models.



Press this button can select up & down swing angle. Fan blow angle can be selected circularly as below:

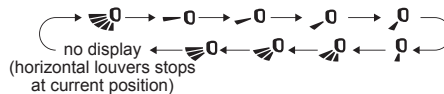

- When selecting " ", air conditioner is blowing fan automatically. Horizontal louver will automatically swing up & down at maximum angle.
- When selecting " , , , ", air conditioner is blowing fan at fixed position. Horizontal louver will stop at the fixed position.
- When selecting " , , ", air conditioner is blowing fan at fixed angle. Horizontal louver will send air at the fixed angle.
- Hold " " button above 2s to set your required swing angle. When reaching your required angle, release the button.

NOTE:

- " , , " may not be available. When air conditioner receives this signal, the air conditioner will blow fan automatically.
- Press this button continuously for more than 2s, the main unit will swing back and forth from up to down, and then loosen the button, the unit present position of guide louver will be kept immediately.
- Under up and down swing mode, when the status is switched from off to , if press this button again 2s later, status will switch to off status directly; if press this button again within 2s, the change of swing status will also depend on the circulation sequence stated above.



- T-ON button
"T-ON" button can set the time for timer on. After pressing this button, " " icon disappears and the word "ON" on remote controller blinks. Press "△" or "▽" button to adjust T-ON setting. After each pressing "△" or "▽" button, T-ON setting will increase or decrease 1min. Hold "△" or "▽" button, 2s later, the time will change quickly until reaching your required time. Press "T-ON" to confirm it. The word "ON" will stop

blinking. "☉" icon resumes displaying. Cancel T-ON: Under the condition that T-ON is started up, press "T-ON" button to cancel it.

- T-OFF button

"T-OFF" button can set the time for timer off. After pressing this button, "☉" icon disappears and the word "OFF" on remote controller blinks. Press "△" or "▽" button to adjust T-OFF setting. After each pressing "△" or "▽" button, T-OFF setting will increase or decrease 1min. Hold "△" or "▽" button, 2s later, the time will change quickly until reaching your required time. Press "T-OFF" word "OFF" will stop blinking.

"☉" icon resumes displaying. Cancel T-OFF. Under the condition that T-OFF is started up, press "T-OFF" button to cancel it.

NOTE:

- Under on and off status, you can set T-OFF or T-ON simultaneously.
- Before setting T-ON or T-OFF, please adjust the clock time.
- After starting up T-ON or T-OFF, set the constant circulating valid.
- After that, air conditioner will be turned on or turned off according to setting time. ON/OFF button has no effect on setting. If you don't need this function, please use remote controller to cancel it.

I FEEL

Press this button to start I FEEL function and "🌡️" will be displayed on the remote controller. After this function is set, the remote controller will send the detected ambient temperature to the controller and the unit will automatically adjust the indoor temperature according to the detected temperature. Press this button again to cancel I FEEL function and "🌡️" will disappear.

- Please put the remote controller near user when this function is set. Do not put the remote controller near the object of high temperature or low temperature in order to avoid detecting inaccurate ambient temperature.

When I FEEL function is turned on, the remote controller should be put within the area where indoor unit can receive the signal sent by the remote controller.

CLOCK

Press this button to set clock time. "☉" icon on remote controller will blink. Press "△" or "▽" button within 5s to set clock time. Each pressing of "△" or "▽" button, clock time will increase or decrease 1 minute. If hold "△" or "▽" button, 2s later, time will change quickly. Release this button when reaching your required time. Press "CLOCK" button to confirm the time. "☉" icon stops blinking.

NOTE:

- Clock time adopts 24-hour mode.

- The interval between two operations can't exceed 5s. Otherwise, remote controller will quit setting status. Operation for TIMER ON/TIMER OFF is the same.

SLEEP

- Press this button, can select Sleep 1 (☾ 1), Sleep 2 (☾ 2), Sleep 3 (☾ 3) and cancel the Sleep, circulate between these, after electrified, Sleep Cancel is defaulted.

- Sleep 1 is Sleep mode 1, in Cool modes; sleep status after run for one hour, the main unit setting temperature will increase 1, two hours, setting temperature increased 2°C, then the unit will run at this setting temperature; In Heat mode: sleep status after run for one hour, the setting temperature will decrease 1, two hours, setting temperature will decrease 2, then the unit will run at this setting temperature.

- Sleep 2 is sleep mode 2, that is air conditioner will run according to the presetting a group of sleep temperature curve.

- Sleep 3-the sleep curve setting under Sleep mode by DIY;
(1) Under Sleep 3 mode, press "TURBO" button for a long time, remote controller enters into user individuation sleep setting status, at this time, the time of remote controller will display "1hour", the setting temperature "88" will display the corresponding temperature of last setting sleep curve and blink (The first entering will display according to the initial curve setting value of original factory);

- (2) Adjust "△" or "▽" button, could change the corresponding setting temperature, after adjusted, press "TURBO" button for confirmation;

- (3) At this time, 1hour will be automatically increased at the timer position on the remote control, (that are "2hours" or "3hours" or "8hours"), the place of setting temperature "88" will display the corresponding temperature of last setting sleep curve and blink;

- (4) Repeat the above step (2)~(3) operation, until 8 hours temperature setting finished, sleep curve setting finished, at this time, the remote controller will resume the original timer display; temperature display will resume to original setting temperature.

- Sleep3- the sleep curve setting under Sleep mode by DIY could be inquired:

The user could accord to sleep curve setting method to inquire the presetting sleep curve, enter into user individuation sleep setting status, but do not change the temperature, press "TURBO" button directly for confirmation. Note: In the above presetting or enquiry procedure, if continuously within 10s, there is no button pressed, the sleep curve setting within 10s, there is no button pressed, the sleep curve setting status will be automatically quit and resume to display the original displaying. In the presetting or enquiry procedure, press "ON/OFF" button, "MODE" button, "SLEEP" button, the sleep curve setting or enquiry status will quit similarly.

WiFi

When the remote controller is OFF, press and hold "MODE" and "WiFi" buttons for about 1s to restore the WiFi module to factory settings and simultaneously enable the WiFi function.

NOTE:

- The function is only available for some models.



Press this button to achieve the on and off of health and scavenging functions in operation station. Press this button for the first time to start scavenging function; LCD displays "🏠". Press the button for the second time to start health and scavenging functions simultaneously; LCD displays "🏠" and "🌿". Press this button for the third time to quit health and scavenging functions simultaneously. Press the button for the fourth time to start health function; LCD display "🌿". Press this button again to repeat the operation above.

- This function is applicable to partial of models .

LIGHT

Press this button to turn off display light on indoor unit. "💡" icon on remote controller disappears.

Press this button again to turn on display light. "💡" icon is displayed.

TEMP

Press this button, you can see indoor set temperature, indoor ambient temperature on indoor unit' s display. The setting on remote controller is selected circularly as below:

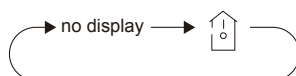

Function introduction for combination buttons

Energy-saving function

Under cooling mode, press "TEMP" and "CLOCK" buttons simultaneously to start up or turn off energy-saving function. When energy-saving function is started up, "SE" will be shown on remote controller, and air conditioner will adjust the set temperature automatically according to ex-factory setting to reach to the best energy-saving effect.

Press "TEMP" and "CLOCK" buttons simultaneously again to exit energy-saving function.

NOTE:

- Under energy-saving function, fan speed is defaulted at auto speed and it can't be adjusted.
- Under energy-saving function, set temperature can't be adjusted. Press "TURBO" button and the remote controller won't send signal.

- Sleep function and energy-saving function can't operate at the same time. If energy-saving function has been set under cool mode, press SLEEP button will cancel energy-saving function. If sleep function has been set under cool mode, start up the energy-saving function will cancel sleep function.

8°C heating function

Under heat mode, press "TEMP" and "CLOCK" buttons simultaneously to start up or turn off 8°C heating function. When this function is started up, "8°C" and "🌡️" will be shown on remote controller, and the air conditioner keep the heating status at 8°C . Press "TEMP" and "CLOCK" buttons simultaneously again to exit 8°C heating function.

NOTE:

- Under 8°C heating function, fan speed is defaulted at auto speed and it can't be adjusted.
- Under 8°C heating function, set temperature can't be adjusted. Press "TURBO" button and the remote controller won't send signal.
- Sleep function and 8°C heating function can't operate at the same time. If 8°C heating function has been set under heat mode, press SLEEP button will cancel 8°C heating function. If sleep function has been set under heat mode, start up the 8°C heating function will cancel sleep function.
- Under °F temperature display, the remote controller will display 46 °F heating.

Child lock function

Press "△" or "▽" simultaneously to turn on or turn off child lock function. When child lock function is on, "🔒" icon is displayed on remote controller. If you operate the remote controller, the "🔒" icon will blink three times without sending signal to the unit.

Temperature display switchover function

Under OFF status, press "▽" and "MODE" buttons simultaneously to switch temperature display between °C and °F .

Replacement of batteries in remote controller

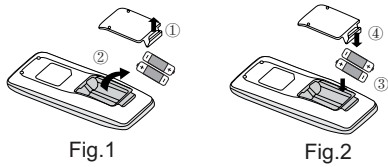

1. Lift the cover along the direction of arrow (as shown in Fig 1 ①).
2. Take out the original batteries (as shown in Fig 1 ②).
3. Place two 7# (AAA 1.5V) dry batteries, and make sure the position of “+” polar and “-” polar is correct (as shown in Fig 2 ③).
4. Reinstall the cover (as shown in Fig 2 ④).

Notice:

- During operation, point the remote control signal sender at the receiving window on indoor unit.
- The distance between signal sender and receiving window should be no more than 8m, and there should be no obstacles between them.
- Signal may be interfered easily in the room where there is fluorescent lamp or wireless telephone; remote controller should be close to indoor unit during operation.
- Replace new batteries of the same model when replacement is required.
- When you don't use remote controller for a long time, please take out the batteries.
- If the display on remote controller is fuzzy or there's no display, please replace batteries.

Introduction for buttons on remote controller

NOTE:

- This is a general use remote controller, it could be used for the air conditioners with multifunction; For some function, which the model doesn't have, if press the corresponding button on the remote controller that the unit will keep the original running status.
- After putting through the power, the air conditioner will give out a sound. After that, you can operate the air conditioner by using remote controller.

1. ON/OFF button

Press this button can turn on or turn off the air conditioner. After turning on the air conditioner, operation indicator "⏻" on indoor unit's display is ON (green indicator. The colour is different for different models), and indoor unit will give out a sound.

2. MODE button

Press this button to select your required operation mode.



- After selecting auto mode, air conditioner will operate automatically according to ambient temperature. Set temperature can't be adjusted and will not be displayed as well. Press "FAN" button can adjust fan speed. Press "↻" button can adjust fan blowing angle.
- After selecting cool mode, air conditioner will operate under cool mode. Press "+" or "-" button to adjust set temperature. Press "FAN" button to adjust fan speed. Press "↻" button to adjust fan blowing angle.
- When selecting dry mode, the air conditioner operates at low speed under dry mode. Under dry mode, fan speed can't be adjusted. Press "↻" button to adjust fan blowing angle.
- When selecting fan mode, the air conditioner will only blow fan, no cooling and no heating. All indicators are OFF. Operation indicator is ON. Press "FAN" button to adjust fan speed. Press "↻" button to adjust fan blowing angle.
- When selecting heating mode, the air conditioner operates under heat mode. Press "+" or "-" button to adjust set temperature. Press "FAN" button to adjust fan speed. Press "↻" button to adjust fan blowing angle. (Cooling only unit won't receive heating mode signal. If setting heat mode with remote controller, press ON/OFF button can't start up the unit).

Note:

- For preventing cold air, after starting up heating mode, indoor unit will delay 1~5 minutes to blow air (actual delay time is depend on indoor ambient temperature).
- Set temperature range from remote controller: 16~30°C ; Fan speed: auto, low speed, medium speed, high speed.

3. +/- button

- Press "+" or "-" button once increase or decrease set temperature 1°C .
- Holding "+" or "-" button, 2s later, set temperature on remote controller will change quickly. On relasing button after setting is finished, temperature indicator on indoor unit will change accordingly. (Temperature can't be adjusted under auto mode)
- When setting TIMER ON, TIMER OFF or CLOCK, press "+" or "-" button to adjust time. (Refer to CLOCK, TIMER ON, TIMER OFF buttons).

4. FAN button

Pressing this button can set fan speed circularly as: auto (AUTO), low(▲), medium(▲▲), high(▲▲▲).

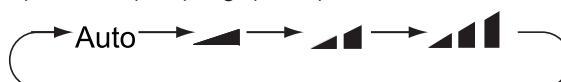

Note:

- Under AUTO Speed, IDU fan motor will adjust the fan speed (high, medium or low speed) according to ambient temperature.
- Fan speed under dry mode is low speed.

5. I FEEL button

Press this button to start I FEEL function and "I FEEL" will be displayed on the remote controller. After this function is set, the remote controller will send the detected ambient temperature to the controller and the unit will automatically adjust the indoor temperature according to the detected temperature. Press this button again to cancel I FEEL function and "I FEEL" will disappear.

- Please put the remote controller near user when this function is set. Do not put the remote controller near the object of high temperature or low temperature in order to avoid detecting inaccurate ambient temperature.
- When I FEEL function is turned on, the remote controller should be put within the area where indoor unit can receive the signal sent by the remote controller.

6. HEALTH button

Press this button to set HEALTH function ON or OFF. After the unit is turned on, it defaults to HEALTH function ON.

- This function is applicable to partial of models.









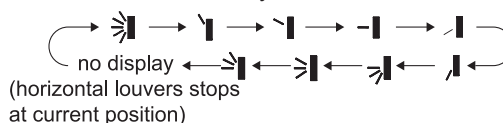

7. AIR button

Press this button to select AIR function ON or OFF. (Only available for some models)



8. SWING button

Press this button can select up&down swing angle. Fan blow angle can be selected circularly as below:





- When selecting "  ", air conditioner is blowing fan automatically. Horizontal louver will automatically swing up & down at maximum angle.
- When selecting "  、  、  、  、  ", air conditioner is blowing fan at fixed position. Horizontal louver will stop at the fixed position.
- When selecting "  、  、  ", air conditioner is blowing fan at fixed angle. Horizontal louver will send air at the fixed angle.
- Hold "  " button above 2s to set your required swing angle. When reaching your required angle, release the button.

Note:

- "  、  、  " may not be available. When air conditioner receives this signal, the air conditioner will blow fan automatically.

9. CLOCK button



Press this button to set clock time. "  " icon on remote controller will blink. Press "+" or "-" button within 5s to set clock time. Each pressing of "+" or "-" button, clock time will increase or decrease 1 minute. If hold "+" or "-" button, 2s later, time will change quickly. Release this button when reaching your required time. Press "CLOCK" button to confirm the time. "  " icon stops blinking.

Note:



- Clock time adopts 24-hour mode.
- The interval between two operations can't exceeds 5s. Otherwise, remote controller will quit setting status. Operation for TIMER ON/TIMER OFF is the same.

10. TIMER ON / TIMER OFF button

• **TIMER ON button**

"TIMER ON" button can set the time for timer on. After pressing this button, "  " icon disappears and the word "ON" on remote controller blinks. Press "+" or "-" button to adjust TIMER ON setting. After each pressing "+" or "-" button, TIMER ON setting will increase or decrease 1min. Hold "+" or "-" button, 2s later, the time will change quickly until reaching your required time. Press "TIMER ON" to confirm it. The word "ON" will stop blinking. "  " icon resumes displaying. Cancel TIMER ON: Under the condition that TIMER ON is started up, press "TIMER ON" button to cancel it.

• **TIMER OFF button**

"TIMER OFF" button can set the time for timer off. After pressing this button, "  " icon disappears and the word "OFF" on remote controller blinks. Press "+" or "-" button to adjust TIMER OFF setting. After each pressing "+" or "-" button, TIMER OFF setting will increase or decrease 1min. Hold "+" or "-" button, 2s later, the time will change quickly until reaching your required time. Press "TIMER OFF" word "OFF" will stop blinking. "  " icon resumes displaying.

Cancel TIMER OFF. Under the condition that TIMER OFF is started up, press "TIMER OFF" button to cancel it.



Note:

- Under on and off status, you can set TIMER OFF or TIMER ON

simultaneously.

- Before setting TIMER ON or TIMER OFF, please adjust the clock time.
- After starting up TIMER ON or TIMER OFF, set the constant circulating valid. After that, air conditioner will be turned on or turned off according to setting time. ON/OFF button has no effect on setting. If you don't need this function, please use remote controller to cancel it.

11. X-FAN button

Press this button under cool and dry mode to start up x-fan function, and "  " icon on remote controller will be displayed. Press this button again to cancel x-fan function, and "  " icon will disappear.



Note:

- When x-fan function is on, if the air conditioner is turned off, indoor fan will still operate at low speed for a while to blow the residual water inside the air duct.
- During x-fan operation, press X-FAN button to turn off x-fan function. Indoor fan will stop operation immediately.

12. TEMP button

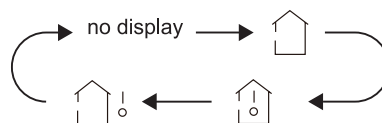
By pressing this button, you can see indoor set temperature, indoor ambient temperature or outdoor ambient temperature on indoor unit's display. The setting on remote controller is selected circularly as below:





- When selecting "  " or no display with remote controller, temperature indicator on indoor unit displays set temperature.
- When selecting "  " with remote controller, temperature indicator on indoor unit displays indoor ambient temperature.
- When selecting "  " with remote controller, temperature indicator on indoor unit displays outdoor ambient temperature.

Note:

- Outdoor temperature display is not available for some models. At that time, indoor unit receives "  " signal, while it displays indoor set temperature.
- It's defaulted to display set temperature when turning on the unit. There is no display in the remote controller.
- Only for the models whose indoor unit has dual-8 display.
- When selecting displaying of indoor or outdoor ambient temperature, indoor temperature indicator displays corresponding temperature and automatically turn to display set temperture after three or five seconds.

13. TURBO button

Under COOL or HEAT mode, press this button to turn to quick COOL or quick HEAT mode. "  " icon is displayed on remote controller. Press this button again to exit turbo function and "  " icon will disappear.

14. SLEEP button

Under COOL, HEAT mode, press this button to start up sleep function. "☾" icon is displayed on remote controller. Press this button again to cancel sleep function and "☾" icon will disappear.

15. LIGHT button

Press this button to turn off display light on indoor unit. "💡" icon on remote controller disappears. Press this button again to turn on display light. "💡" icon is displayed.

Function introduction for combination buttons

Child lock function

Press "+" and "-" simultaneously to turn on or turn off child lock function. When child lock function is on, "🔒" icon is displayed on remote controller. If you operate the remote controller, the "🔒" icon will blink three times without sending signal to the unit.

Temperature display switchover function

Under OFF status, press "-" and "MODE" buttons simultaneously to switch temperature display between °C and °F.

Replacement of batteries in remote controller

1. Press the back side of remote controller marked with "🔓" , as shown in the fig. and then push out the cover of battery box along the arrow direction.
2. Replace two 7# (AAA 1.5V) dry batteries, and make sure the position of "+" polar and "-" polar are correct.
3. Reinstall the cover of battery box.

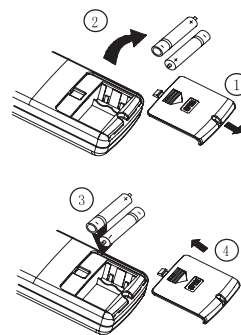

Sketch map for replacing batteries

Notice:

- During operation, point the remote control signal sender at the receiving window on indoor unit.
- The distance between signal sender and receiving window should be no more than 8m, and there should be no obstacles between them.
- Signal may be interfered easily in the room where there is fluorescent lamp or wireless telephone; remote controller should be close to indoor unit during operation.
- Replace new batteries of the same model when replacement is required.
- When you don't use remote controller for a long time, please take out the batteries.
- If the display on remote controller is fuzzy or there's no display, please replace batteries.

6.3 Brief Description of Models and Functions

● Indoor Unit

1. Basic function of system

(1) Cooling mode

- (1) Under this mode, fan and swing operates at setting status. Temperature setting range is 16~30°C.
- (2) During malfunction of outdoor unit or the unit is stopped because of protection, indoor unit keeps original operation status.

(2)Drying mode

- (1) Under this mode, fan operates at low speed and swing operates at setting status. Temperature setting range is 16~30°C.
- (2) During malfunction of outdoor unit or the unit is stopped because of protection, indoor unit keeps original operation status.
- (3) Protection status is same as that under cooling mode.
- (4) Sleep function is not available for drying mode.

(3)Heating mode

- (1) Under this mode, Temperature setting range is 16~30°C.
- (2) Working condition and process for heating mode:
When turn on the unit under heating mode, indoor unit enters into cold air prevention status. When the unit is stopped or at OFF status, and indoor unit has been started up just now, the unit enters into residual heat-blowing status.

(4)Working method for AUTO mode:

1. Working condition and process for AUTO mode:
 - a. Under AUTO mode, standard heating $T_{\text{preset}}=20^{\circ}\text{C}$ and standard cooling $T_{\text{preset}}=25^{\circ}\text{C}$. The unit will switch mode automatically according to ambient temperature.
 2. Protection function
 - a. During cooling operation, protection function is same as that under cooling mode.
 - b. During heating operation, protection function is same as that under heating mode.
 3. Display: Set temperature is the set value under each condition. Ambient temperature is $(T_{\text{amb.}}-T_{\text{compensation}})$ for heat pump unit and $T_{\text{amb.}}$ for cooling only unit.
 4. If there's I feel function, $T_{\text{compensation}}$ is 0. Others are same as above.

(5)Fan mode

Under this mode, indoor fan operates at set fan speed. Compressor, outdoor fan, 4-way valve and electric heating tube stop operation. Indoor fan can select to operate at high, medium, low or auto fan speed. Temperature setting range is 16~30°C.

2. Other control

(1) Buzzer

Upon energization or availablely operating the unit or remote controller, the buzzer will give out a beep.

(2) Auto button

If press this auto button when turning off the unit, the complete unit will operate at auto mode. Indoor fan operates at auto fan speed and swing function is turned on. Press this auto button at ON status to turn off the unit.

(3) Auto fan

Heating mode: During auto heating mode or normal heating mode, auto fan speed will adjust the fan speed automatically according to ambient temperature and set temperature.

(4) Sleep

After setting sleep function for a period of time, system will adjust set temperature automatically.

(5) Timer function:

General timer and clock timer functions are compatible by equipping remote controller with different functions.

(6) Memory function

memorize compensation temperature, off-peak energization value. Memory content: mode, up&down swing, light, set temperature, set fan speed, general timer (clock timer Can't be memorized). After power recovery, the unit will be turned on automatically according to memory content.

(7) Health function

During operation of indoor fan, set health function by remote controller. Turn off the unit will also turn off health function. Turn on the unit by pressing auto button, and the health is defaulted ON. (Health function is not available for this unit)

(8)I feel control mode

After controller received I feel control signal and ambient temperature sent by remote controller, controller will work according to the ambient temperature sent by remote controller.

(9)Compulsory defrosting function

(1) Start up compulsory defrosting function
Under ON status, set heating mode with remote controller and adjust the temperature to 16°C. Press “ Δ , ∇ , Δ , ∇ , Δ , ∇ (+,-,+,-,+,-)” button successively within 5s and the complete unit will

enter into compulsory defrosting status. Meanwhile, heating indicator on indoor unit will ON 10s and OFF 0.5s successively. (Note: If complete unit has malfunction or stops operation due to protection, compulsory defrosting function can be started up after malfunction or protection is resumed.

(2) Exit compulsory defrosting mode

After compulsory defrosting is started up, the complete unit will exit defrosting operation according to the actual defrosting result, and the complete unit will resume normal heating operation.

(10)Refrigerant recovery function:

(1) Enter refrigerant recycling function

Within 5min after energizing (unit ON or OFF status is ok), continuously press LIGHT button for 3 times within 3s to enter refrigerant recycling mode; Fo is displayed and refrigerant recycling function is started. At this moment, the maintenance people closes liquid valve.

After 5min, stick the thimble of maintenance valve with a tool. If there is no refrigerant spraying out, close the gas valve immediately and then turn off the unit to remove the connection pipe.

(2) Exit refrigerant recycling function

After entering refrigerant recycling mode, when receive any remote control signal or enter refrigerant recycling mode for 25min, the unit will exit refrigerant recycling mode automatically. If the unit is in standby mode before refrigerant recycling, it will be still in standby mode after finishing refrigerant recycling; if the unit is in ON status before refrigerant recycling, it will still run in original operation mode.

(11)Ambient temperature display control mode

1. When user set the remote controller to display set temperature (corresponding remote control code: 01), current set temperature will be displayed.

2. Only when remote control signal is switched to indoor ambient temperature display status (corresponding remote control code: 10) from other display status (corresponding remote control code: 00, 01,11),controller will display indoor ambient temperature for 3s and then turn back to display set temperature.

Under this mode, indoor fan operates at set fan speed. Compressor, outdoor fan, 4-way valve and electric heating tube stop operation. Indoor fan can select to operate at high, medium, low or auto fan speed. Temperature setting range is 16~30°C.

(12)Off-peak energization function:

Adjust compressors minimum stop time. The original minimum stop time is 180s and then we change to:

The time interval between two start-ups of compressor Can't be less than 180+Ts(0≤T≤15). T is the variable of controller. Thats to say the minimum stop time of compressor is 180s~195s. Read-in T into memory chip when refurbish the memory chip each time. After power recovery, compressor can only be started up after 180+T s at least.

(13) SE control mode

The unit operates at SE status.

(14) X-fan mode

When X-fan function is turned on, after turn off the unit, indoor fan will still operate at low speed for 2min and then the complete unit will be turned off. When x-fan function is turned off, after turn off the unit, the complete unit will be turned off directly.

(15) 8°C heating function

Under heating mode, you can set 8°C heating function by remote controller. The system will operate at 8°C set temperature.

(16)Turbo function

Turbo function can be set under cooling and heating modes. Press Fan Speed button to cancel turbo setting. Turbo function is not available under auto, drying and fan modes.

(17)Instructions to the Error Indicating Lamps on the Panel of the Cassette Type Unit.

GKH(09)EB-D6DNA5A/I GKH(12)EB-D6DNA5A/I GKH(18)EB-D6DNA5A/I

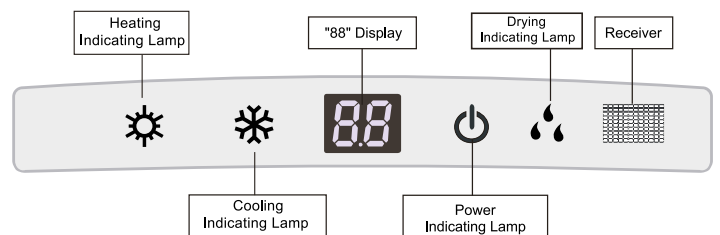

GKH(24)EC-D6DNA6A/I

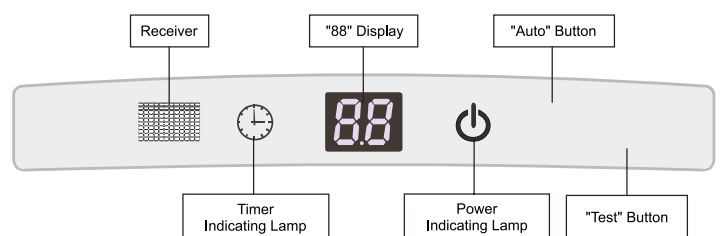

GKH(09)DA-D6DNA1A/I GKH(12)DA-D6DNA1A/I
GKH(18)DA-D6DNA1A/I GKH(20)DA-D6DNA1A/I

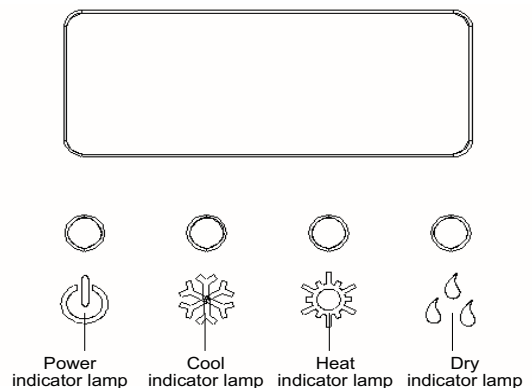

● Heating Indicating Lamp:
When this indicator is on, it indicates the heating mode is turned on.

- Cooling Indicating Lamp:

When this indicator is on, it indicates the cooling mode is turned on.

- Drying Indicating Lamp

When this indicator is on, it indicates the dry mode is turned on.

- Power and ON/OFF Indicating Lamp:

It goes red when the unit is powered on while it goes white when the unit is started.

- Timer Indicating Lamp:

Timer indicator on indoor unit will be on when timer ON is set under off status and timer OFF is set under on status.

- “88” Display:

When there is no error, the dual-8 nixie tube display the set temperature. After receiving the command of displaying indoor ambient temperature from the remote controller, the dual-8 nixie tube displays indoor temperature for 3s and then resume to display the set temperature. If there is error, error code will be displayed. If there's multiple error, error codes will be displayed in turn.

“Auto” button It's used for turning on or turning off the unit. When use this button to turn in the unit, the unit is under auto mode.

“Test” button It's only used for the test units. This button is only valid within 3mins after the unit is energized.

NOTE:

If the light of indoor unit is turned off, when operating the remote controller to send command, the display will be on for 3s and then off.

7. Notes for Installation and Maintenance

Safety Precautions: Important!

Please read the safety precautions carefully before installation and maintenance.

The following contents are very important for installation and maintenance.

Please follow the instructions below.

- The installation or maintenance must accord with the instructions.
- Comply with all national electrical codes and local electrical codes.
- Pay attention to the warnings and cautions in this manual.
- All installation and maintenance shall be performed by distributor or qualified person.
- All electric work must be performed by a licensed technician according to local regulations and the instructions given in this manual.
- Be caution during installation and maintenance. Prohibit incorrect operation to prevent electric shock, casualty and other accidents.



WARNINGS

Electrical Safety Precautions:

1. Cut off the power supply of air conditioner before checking and maintenance.
2. The air condition must apply specialized circuit and prohibit share the same circuit with other appliances.
3. The air conditioner should be installed in suitable location and ensure the power plug is touchable.
4. Make sure each wiring terminal is connected firmly during installation and maintenance.
5. Have the unit adequately grounded. The grounding wire Can't be used for other purposes.
6. Must apply protective accessories such as protective boards, cable-cross loop and wire clip.
7. The live wire, neutral wire and grounding wire of power supply must be corresponding to the live wire, neutral wire and grounding wire of the air conditioner.
8. The power cord and power connection wires Can't be pressed by hard objects.
9. If power cord or connection wire is broken, it must be replaced by a qualified person.
10. If the power cord or connection wire is not long enough, please get the specialized power cord or connection wire from the manufacture or distributor. Prohibit prolong the wire by yourself.

11. For the air conditioner without plug, an air switch must be installed in the circuit. The air switch should be all-pole parting and the contact parting distance should be more than 3mm.

12. Make sure all wires and pipes are connected properly and the valves are opened before energizing.

13. Check if there is electric leakage on the unit body. If yes, please eliminate the electric leakage.

14. Replace the fuse with a new one of the same specification if it is burnt down; dont replace it with a cooper wire or conducting wire.

15. If the unit is to be installed in a humid place, the circuit breaker must be installed.

Installation Safety Precautions:

1. Select the installation location according to the requirement of this manual.(See the requirements in installation part)
2. Handle unit transportation with care; the unit should not be carried by only one person if it is more than 20kg.
3. When installing the indoor unit and outdoor unit, a sufficient fixing bolt must be installed; make sure the installation support is firm.
4. Ware safety belt if the height of working is above 2m.
5. Use equipped components or appointed components during installation.
6. Make sure no foreign objects are left in the unit after finishing installation.

Refrigerant Safety Precautions:

1. When refrigerant leaks or requires discharge during installation, maintenance, or disassembly, it should be handled by certified professionals or otherwise in compliance with local laws and regulations.
- 2.Avoid contact between refrigerant and fire as it generates poisonous gas; Prohibit prolong the connection pipe by welding.
3. Apply specified refrigerant only. Never have it mixed with any other refrigerant. Never have air remain in the refrigerant line as it may lead to rupture or other hazards.
4. Make sure no refrigerant gas is leaking out when installation is completed.
5. If there is refrigerant leakage, please take sufficient measure to minimize the density of refrigerant.
6. Never touch the refrigerant piping or compressor without wearing glove to avoid scald or frostbite.

Improper installation may lead to fire hazard, explosion, electric shock or injury.

Safety Precautions for Installing and Relocating the Unit:

To ensure safety, please be mindful of the following precautions.

WARNINGS

1. When installing or relocating the unit, be sure to keep the refrigerant circuit free from air or substances other than the specified refrigerant.

Any presence of air or other foreign substance in the refrigerant circuit will cause system pressure rise or compressor rupture, resulting in injury.

2. When installing or moving this unit, do not charge the refrigerant which is not comply with that on the nameplate or unqualified refrigerant.

Otherwise, it may cause abnormal operation, wrong action, mechanical malfunction or even series safety accident.

3. When refrigerant needs to be recovered during relocating or repairing the unit, be sure that the unit is running in cooling mode. Then, fully close the valve at high pressure side (liquid valve). About 30-40 seconds later, fully close the valve at low pressure side (gas valve), immediately stop the unit and disconnect power. Please note that the time for refrigerant recovery should not exceed 1 minute.

If refrigerant recovery takes too much time, air may be sucked in and cause pressure rise or compressor rupture, resulting in injury.

4. During refrigerant recovery, make sure that liquid valve and gas valve are fully closed and power is disconnected before detaching the connection pipe.

If compressor starts running when stop valve is open and connection pipe is not yet connected, air will be sucked in and cause pressure rise or compressor rupture, resulting in injury.

5. When installing the unit, make sure that connection pipe is securely connected before the compressor starts running.

If compressor starts running when stop valve is open and connection pipe is not yet connected, air will be sucked in and cause pressure rise or compressor rupture, resulting in injury.

6. Prohibit installing the unit at the place where there may be leaked corrosive gas or flammable gas.

If there leaked gas around the unit, it may cause explosion and other accidents.

7. Do not use extension cords for electrical connections. If the electric wire is not long enough, please contact a local service center authorized and ask for a proper electric wire.

Poor connections may lead to electric shock or fire.

8. Use the specified types of wires for electrical connections between the indoor and outdoor units. Firmly clamp the wires so that their terminals receive no external stresses.

Electric wires with insufficient capacity, wrong wire connections and insecure wire terminals may cause electric shock or fire.

Safety Precautions for Refrigerant

- To realize the function of the air conditioner unit, a special refrigerant circulates in the system. The used refrigerant is the fluoride R32, which is specially cleaned. The refrigerant is flammable and odorless. Furthermore, it can lead to explosion under certain conditions. But the flammability of the refrigerant is very low. It can be ignited only by fire.
- Compared to common refrigerants, R32 is a nonpolluting refrigerant with no harm to the ozone layer. The influence upon the greenhouse effect is also lower. R32 has got very good thermodynamic features which lead to a really high energy efficiency. The units therefore need a less filling.

WARNING:

- Do not use means to accelerate the defrosting process or to clean, other than those recommended by the manufacturer. Should repair be necessary, contact your nearest authorized Service Centre. Any repairs carried out by unqualified personnel may be dangerous. The appliance shall be stored in a room without continuously operating ignition sources. (for example: open flames, an operating gas appliance or an operating electric heater.)
- Do not pierce or burn.
- Appliance shall be installed, operated and stored in a room with a floor area larger than X m².
- Appliance filled with flammable gas R32. For repairs, strictly follow manufacturer's instructions only. Be aware that refrigerants do not contain odor.
- Read specialist manual.



Safety Operation of Flammable Refrigerant

Qualification requirement for installation and maintenance man

- All the work men who are engaged in the refrigeration system should bear the valid certification awarded by the authoritative organization and the qualification for dealing with the refrigeration system recognized by this industry. If it needs other technician to maintain and repair the appliance, they should be supervised by the person who bears the qualification for using the flammable refrigerant.
- It can only be repaired by the method suggested by the equipment manufacturer.

Installation notes

- The air conditioner is not allowed to use in a room that has running fire (such as fire source, working coal gas ware, operating heater).
 - It is not allowed to drill hole or burn the connection pipe.
 - The air conditioner must be installed in a room that is larger than the minimum room area.
- The minimum room area is shown on the nameplate or following table a.
- Leak test is a must after installation.

table a - Minimum room area (m²)

Charge Amount (kg)	Installation High (m)			
	0.6 (Floor Location)	1.8 (Wall Mounted)	2.2 (Ceiling Mounted)	2.5
Minimum Room Area (m ²)				
≤1.842	/	/	/	/
1.85	29.2	4.5	3.7	3.3
1.9	30.8	4.6	3.8	3.4
1.95	32.4	4.8	3.9	3.4
2	34.1	4.9	4.0	3.5
2.05	35.8	5.0	4.1	3.6
2.1	37.6	5.1	4.2	3.7
2.15	39.4	5.2	4.3	3.8
2.2	41.2	5.4	4.4	3.9
2.3	45.1	5.6	4.6	4.0
2.4	49.1	5.8	4.8	4.2
2.5	53.3	6.1	5.0	4.4
2.6	57.6	6.4	5.2	4.6
2.7	62.1	6.9	5.4	4.7
2.8	66.8	7.5	5.6	4.9
2.9	71.6	8.0	5.8	5.1
3	76.7	8.6	6.0	5.3
3.1	81.9	9.1	6.2	5.4
3.2	87.2	9.7	6.5	5.6
3.3	92.7	10.3	6.9	5.8
3.4	98.5	11.0	7.4	6.0
3.5	104.3	11.6	7.8	6.1

Maintenance notes

- Check whether the maintenance area or the room area meet the requirement of the nameplate.
 - Its only allowed to be operated in the rooms that meet the requirement of the nameplate.
- Check whether the maintenance area is well-ventilated.
 - The continuous ventilation status should be kept during the operation process.
- Check whether there is fire source or potential fire source in the maintenance area.
 - The naked flame is prohibited in the maintenance area; and the “no smoking” warning board should be hanged.
- Check whether the appliance mark is in good condition.
 - Replace the vague or damaged warning mark.

Welding

- If you should cut or weld the refrigerant system pipes in the process of maintaining, please follow the steps as below:
 - a. Shut down the unit and cut power supply
 - b. Eliminate the refrigerant
 - c. Vacuuming
 - d. Clean it with N₂ gas

- e. Cutting or welding
- f. Carry back to the service spot for welding
 - Make sure that there isn't any naked flame near the outlet of the vacuum pump and it's well-ventilated.
 - The refrigerant should be recycled into the specialized storage tank.

Filling the refrigerant

- Use the refrigerant filling appliances specialized for R32. Make sure that different kinds of refrigerant won't contaminate with each other.
- The refrigerant tank should be kept upright at the time of filling refrigerant.
- Stick the label on the system after filling is finished (or haven't finished).
- Don't overfilling.
- After filling is finished, please do the leakage detection before test running; another time of leak detection should be done when it's removed.

Safety instructions for transportation and storage

- Please use the flammable gas detector to check before unload and open the container.
- No fire source and smoking.
- According to the local rules and laws.

Specialist's Manual

- The following checks shall be applied to installations using flammable refrigerants:
 - the charge size is in accordance with the room size within which the refrigerant containing parts are installed;
 - the ventilation machinery and outlets are operating adequately and are not obstructed;
 - if an indirect refrigerating circuit is being used, the secondary circuit shall be checked for the presence of refrigerant;
 - marking to the equipment continues to be visible and legible. Markings and signs that are illegible shall be corrected;
 - refrigerating pipe or components are installed in a position where they are unlikely to be exposed to any substance which may corrode refrigerant containing components, unless the components are constructed of materials which are inherently resistant to being corroded or are suitably protected against being so corroded.
- Repair and maintenance to electrical components shall include initial safety checks and component inspection procedures. If a fault exists that could compromise safety, then no electrical supply shall be connected to the circuit until it is satisfactorily dealt with. If the fault cannot be corrected immediately but it is necessary to continue operation, an adequate temporary solution shall be used. This shall be reported to the owner of the equipment so all parties are advised.
 - Initial safety checks shall include:
 - that capacitors are discharged: this shall be done in a safe manner to avoid possibility of sparking;
 - that no live electrical components and wiring are exposed while charging, recovering or purging the system;
 - that there is continuity of earth bonding.

- Checks to the area

Prior to beginning work on systems containing flammable refrigerants, safety checks are necessary to ensure that the risk of ignition is minimised. For repair to the refrigerating system, "Work procedure" to "No ignition sources" shall be completed prior to conducting work on the system.

- Work procedure

Work shall be undertaken under a controlled procedure so as to minimise the risk of a flammable gas or vapour being present while the work is being performed.

- General work area

All maintenance staff and others working in the local area shall be instructed on the nature of work being carried out. Work in confined spaces shall be avoided.

- Checking for presence of refrigerant

The area shall be checked with an appropriate refrigerant detector prior to and during work, to ensure the technician is aware of potentially toxic or flammable atmospheres. Ensure that the leak detection equipment being used is suitable for use with all applicable refrigerants, i.e. non-sparking, adequately sealed or intrinsically safe.

- Presence of fire extinguisher

If any hot work is to be conducted on the refrigerating equipment or any associated parts, appropriate fire extinguishing equipment shall be available to hand. Have a dry powder or CO₂ fire extinguisher adjacent to the charging area.

- Ventilated area

Ensure that the area is in the open or that it is adequately ventilated before breaking into the system or conducting any hot work. A degree of ventilation shall continue during the period that the work is carried out. The ventilation should safely disperse any released refrigerant and preferably expel it externally into the atmosphere.

- Checks to the refrigerating equipment

Where electrical components are being changed, they shall be fit for the purpose and to the correct specification. At all times the manufacturer's maintenance and service guidelines shall be followed. If in doubt, consult the manufacturer's technical department for assistance.

The following checks shall be applied to installations using flammable refrigerants:

 - the actual refrigerant charge is in accordance with the room size within which the refrigerant containing parts are installed;
 - the ventilation machinery and outlets are operating adequately and are not obstructed;
 - if an indirect refrigerating circuit is being used, the secondary circuit shall be checked for the presence of refrigerant;
 - marking to the equipment continues to be visible and legible. Markings and signs that are illegible shall be corrected;
 - refrigerating pipe or components are installed in a position where they are unlikely to be exposed to any substance which may corrode refrigerant containing components, unless the components are constructed of materials which are inherently resistant to being corroded or are suitably protected against being so corroded.

- **Checks to electrical devices**

Repair and maintenance to electrical components shall include initial safety checks and component inspection procedures. If a fault exists that could compromise safety, then no electrical supply shall be connected to the circuit until it is satisfactorily dealt with. If the fault cannot be corrected immediately but it is necessary to continue operation, an adequate temporary solution shall be used. This shall be reported to the owner of the equipment so all parties are advised.

Initial safety checks shall include:

- that capacitors are discharged: this shall be done in a safe manner to avoid possibility of sparking;
- that no live electrical components and wiring are exposed while charging, recovering or purging the system;
- that there is continuity of earth bonding.

- **No ignition sources**

No person carrying out work in relation to a refrigerating system which involves exposing any pipe work shall use any sources of ignition in such a manner that it may lead to the risk of fire or explosion. All possible ignition sources, including cigarette smoking, should be kept sufficiently far away from the site of installation, repairing, removing and disposal, during which refrigerant can possibly be released to the surrounding space.

Prior to work taking place, the area around the equipment is to be surveyed to make sure that there are no flammable hazards or ignition risks. "No Smoking" signs shall be displayed.

- **Repairs to sealed components**

During repairs to sealed components, all electrical supplies shall be disconnected from the equipment being worked upon prior to any removal of sealed covers, etc. If it is absolutely necessary to have an electrical supply to equipment during servicing, then a permanently operating form of leak detection shall be located at the most critical point to warn of a potentially hazardous situation.

Particular attention shall be paid to the following to ensure that by working on electrical components, the casing is not altered in such a way that the level of protection is affected. This shall include damage to cables, excessive number of connections, terminals not made to original specification, damage to seals, incorrect fitting of glands, etc.

- Ensure that the apparatus is mounted securely.
- Ensure that seals or sealing materials have not degraded to the point that they no longer serve the purpose of preventing the ingress of flammable atmospheres. Replacement parts shall be in accordance with the manufacturer's specifications.

NOTE:

The use of silicon sealant can inhibit the effectiveness of some types of leak detection equipment. Intrinsically safe components do not have to be isolated prior to working on them.

- **Repair to intrinsically safe components**

Do not apply any permanent inductive or capacitance loads to the circuit without ensuring that this will not exceed the permissible voltage and current permitted for the equipment in use.

Intrinsically safe components are the only types that can be worked on while live in the presence of a flammable atmosphere. The test apparatus shall be at the correct rating. Replace components only with parts specified by the

manufacturer. Other parts may result in the ignition of refrigerant in the atmosphere from a leak.

- **Cabling**

Check that cabling will not be subject to wear, corrosion, excessive pressure, vibration, sharp edges or any other adverse environmental effects. The check shall also take into account the effects of aging or continual vibration from sources such as compressors or fans.

- **Leak detection methods**

Leak detection fluids are suitable for use with most refrigerants but the use of detergents containing chlorine shall be avoided as the chlorine may react with the refrigerant and corrode the copper pipe-work.

- **Detection of flammable refrigerants**

Under no circumstances shall potential sources of ignition be used in the searching for or detection of refrigerant leaks. A halide torch (or any other detector using a naked flame) shall not be used.

The following leak detection methods are deemed acceptable for all refrigerant systems.

Electronic leak detectors may be used to detect refrigerant leaks but, in the case of flammable refrigerants, the sensitivity may not be adequate, or may need re-calibration. (Detection equipment shall be calibrated in a refrigerant-free area.) Ensure that the detector is not a potential source of ignition and is suitable for the refrigerant used. Leak detection equipment shall be set at a percentage of the LFL of the refrigerant and shall be calibrated to the refrigerant employed, and the appropriate percentage of gas (25% maximum) is confirmed.

Leak detection fluids are also suitable for use with most refrigerants but the use of detergents containing chlorine shall be avoided as the chlorine may react with the refrigerant and corrode the copper pipe-work.

NOTE: Examples of leak detection fluids are

- bubble method,
- fluorescent method agents.

If a leak is suspected, all naked flames shall be removed/extinguished.

If a leakage of refrigerant is found which requires brazing, all of the refrigerant shall be recovered from the system, or isolated (by means of shut off valves) in a part of the system remote from the leak. Removal of refrigerant shall be according to clause "Removal and evacuation".

- **Removal and evacuation**

When breaking into the refrigerant circuit to make repairs — or for any other purpose — conventional procedures shall be used. However, for flammable refrigerants it is important that best practice is followed since flammability is a consideration. The following procedure shall be adhered to:

- remove refrigerant;
- purge the circuit with inert gas (optional for A2L);
- evacuate (optional for A2L);
- purge with inert gas (optional for A2L);
- open the circuit by cutting or brazing.

The refrigerant charge shall be recovered into the correct recovery cylinders.

For appliances containing flammable refrigerants, the system shall be "flushed" with OFN to render the unit safe. This process may need to be repeated several times. Compressed air or oxygen shall not be used for purging refrigerant

systems.

For appliances containing flammable refrigerants, flushing shall be achieved by breaking the vacuum in the system with OFN and continuing to fill until the working pressure is achieved, then venting to atmosphere, and finally pulling down to a vacuum. This process shall be repeated until no refrigerant is within the system. When the final OFN charge is used, the system shall be vented down to atmospheric pressure to enable work to take place. This operation is absolutely vital if brazing operations on the pipe-work are to take place.

Ensure that the outlet for the vacuum pump is not close to any ignition sources and that ventilation is available.

• Charging procedures

In addition to conventional charging procedures, the following requirements shall be followed.

— Ensure that contamination of different refrigerants does not occur when using charging equipment. Hoses or lines shall be as short as possible to minimise the amount of refrigerant contained in them.

— Cylinders shall be kept in an appropriate position according to the instructions.

— Ensure that the refrigerating system is earthed prior to charging the system with refrigerant.

— Label the system when charging is complete (if not already).

— Extreme care shall be taken not to overfill the refrigerating system.

Prior to recharging the system, it shall be pressure-tested with the appropriate purging gas. The system shall be leak-tested on completion of charging but prior to commissioning. A follow up leak test shall be carried out prior to leaving the site.

• Decommissioning

Before carrying out this procedure, it is essential that the technician is completely familiar with the equipment and all its detail. It is recommended good practice that all refrigerants are recovered safely. Prior to the task being carried out, an oil and refrigerant sample shall be taken in case analysis is required prior to re-use of recovered refrigerant. It is essential that electrical power is available before the task is commenced.

a) Become familiar with the equipment and its operation.

b) Isolate system electrically.

c) Before attempting the procedure, ensure that:

— mechanical handling equipment is available, if required, for handling refrigerant cylinders;

— all personal protective equipment is available and being used correctly;

— the recovery process is supervised at all times by a competent person;

— recovery equipment and cylinders conform to the appropriate standards.

d) Pump down refrigerant system, if possible.

e) If a vacuum is not possible, make a manifold so that refrigerant can be removed from various parts of the system.

f) Make sure that cylinder is situated on the scales before recovery takes place.

g) Start the recovery machine and operate in accordance with manufacturer's instructions.

h) Do not overfill cylinders. (No more than 80% volume liquid charge).

i) Do not exceed the maximum working pressure of the

cylinder, even temporarily.

j) When the cylinders have been filled correctly and the process completed, make sure that the cylinders and the equipment are removed from site promptly and all isolation valves on the equipment are closed off.

k) Recovered refrigerant shall not be charged into another refrigerating system unless it has been cleaned and checked.

• Labelling

Equipment shall be labelled stating that it has been decommissioned and emptied of refrigerant. The label shall be dated and signed. For appliances containing flammable refrigerants, ensure that there are labels on the equipment stating the equipment contains flammable refrigerant.

• Recovery

When removing refrigerant from a system, either for servicing or decommissioning, it is recommended good practice that all refrigerants are removed safely.

When transferring refrigerant into cylinders, ensure that only appropriate refrigerant recovery cylinders are employed. Ensure that the correct number of cylinders for holding the total system charge is available. All cylinders to be used are designated for the recovered refrigerant and labelled for that refrigerant (i.e. special cylinders for the recovery of refrigerant). Cylinders shall be complete with pressure-relief valve and associated shut-off valves in good working order. Empty recovery cylinders are evacuated and, if possible, cooled before recovery occurs.

The recovery equipment shall be in good working order with a set of instructions concerning the equipment that is at hand and shall be suitable for the recovery of all appropriate refrigerants including, when applicable, flammable refrigerants. In addition, a set of calibrated weighing scales shall be available and in good working order. Hoses shall be complete with leakfree disconnect couplings and in good condition. Before using the recovery machine, check that it is in satisfactory working order, has been properly maintained and that any associated electrical components are sealed to prevent ignition in the event of a refrigerant release. Consult manufacturer if in doubt.

The recovered refrigerant shall be returned to the refrigerant supplier in the correct recovery cylinder, and the relevant waste transfer note arranged. Do not mix refrigerants in recovery units and especially not in cylinders.

If compressors or compressor oils are to be removed, ensure that they have been evacuated to an acceptable level to make certain that flammable refrigerant does not remain within the lubricant. The evacuation process shall be carried out prior to returning the compressor to the suppliers. Only electric heating to the compressor body shall be employed to accelerate this process.

When oil is drained from a system, it shall be carried out safely.

• General

That the installation of pipe-work shall be kept to a minimum. That compliance with national gas regulations shall be observed.

That mechanical connections made in accordance with 22.118 shall be accessible for maintenance purposes.

Main Tools for Installation and Maintenance



Level meter



Measuring tape



Screw driver



Impact drill



Drill head



Electric drill



Electroprobe



Universal meter



Torque wrench



Open-end wrench



Inner hexagon spanner



Electronic leakage detector



Vacuum pump



Pressure meter



Pipe pliers



Pipe pliers



Pipe cutter



Pipe expander



Pipe bender



Soldering appliance



Refrigerant container



Electronic scale

8. Installation

8.1 Outline of the Unit and Main Parts

GKH(09)EB-D6DNA5A/I GKH(12)EB-D6DNA5A/I GKH(18)EB-D6DNA5A/I GKH(24)EC-D6DNA6A/I

Indoor

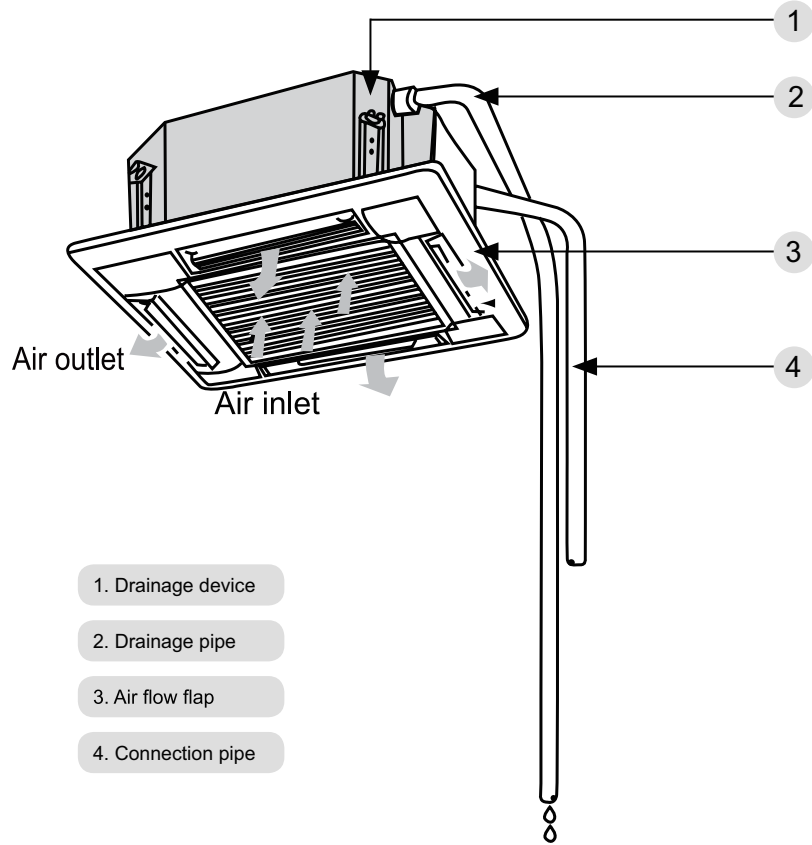

GKH(09)DA-D6DNA1A/I GKH(12)DA-D6DNA1A/I GKH(18)DA-D6DNA1A/I GKH(20)DA-D6DNA1A/I

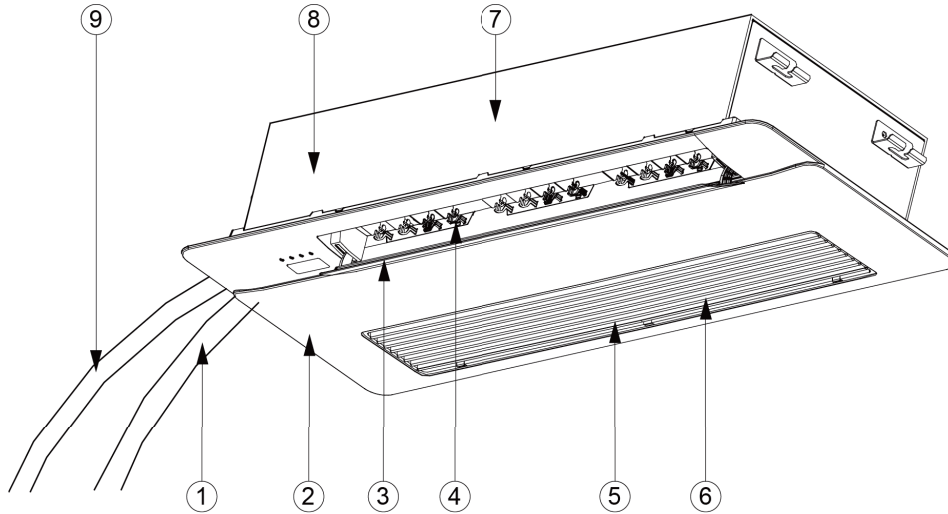

No.	①	②	③	④	⑤
Name	Connection pipe	Panel	Air louver	Swing blade	Air-in grille
No.	⑥	⑦	⑧	⑨	—
Name	Built-in filter	Main body	Drainage device (built-in)	Drainage Pipe	—

















8.2 Preparative for Installation

GKH(09)EB-D6DNA5A/I GKH(12)EB-D6DNA5A/I GKH(18)EB-D6DNA5A/I GKH(24)EC-D6DNA6A/I

1. Standard Accessory Parts

The standard accessory parts listed below are furnished and should be used as required.

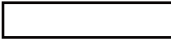
Table 1

Indoor Unit Accessories				
No.	Name	Appearance	Q'ty	Usage
1	Drain Hose		1	To connect with the hard PVC drain pipe
2	Nut with Washer		4	To fix the hook on the cabinet of the unit.
3	Washer		10	To be used together with the hanger bolt for installing the unit.
4	Installation Paperboard		1	Used for ceiling drilling
5	Gasket Mounting Board		4	Used to prevent gasket from falling off
6	Remote Controller +Battery		1+2	To control the indoor unit
7	Sealing Plaster		1	Used for holes through the wall
8	Fastener		6	To fasten the sponge
9	Insulation		1	To insulate the gas pipe
10	Insulation		1	To insulate the liquid pipe
11	Sponge		4	To insulate the drain pipe
12	Nut		1	To connect gas pipe
13	Nut		1	To connect liquid pipe
14	Enswathement		2	Used for winding the pipe connecting the indoor and outdoor units
15	Heat-Shrinkable Bushing		1	Connect the front panel to the main body
16	Bolt Assembly		4	Connect the panel and body (only 12K/18K)

2. Selection of the Installation Location

WARNING!

The unit must be installed where strong enough to withstand the weight of the unit and fixed securely, otherwise the unit would topple or fall off.

CAUTION!







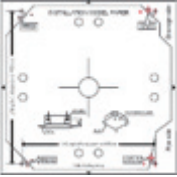

- ① . Do not install where there is the danger of combustible gas leakage.
- ② . Do not install the unit near heat source of heat, steam, or flammable gas.
- ③ . Children under 10 years old must be supervised not to operate the unit.

Decide the installation location with the customer as follows:

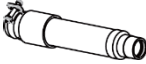
⚠ NOTE! This picture is for reference only, please refer to the actual product, the unit of dimension is mm.

1. Standard Fittings

Use the following provided accessories according to the requirement.

No.	Name	Appearance	Q'ty	Usage
1	Wireless controller		1	To control the indoor unit
2	Paper pattern for installation		1	Locate the drill hole on ceiling
3	Tapping screw with washer		4	Fix paper pattern
4	Washer fixing plate		4	Prevent the washer from falling off
5	Drain Hose Assembly		1	To connect with the hard PVC drain pipe
6	M10 Washer		10	To be used together with the hanger bolt for installing the unit.
7	Insulation		1	To insulate the gas pipe
8	Insulation		1	To insulate the liquid pipe
9	Sponge		1	To insulate the drain pipe
10	Fastener		4	To fasten the sponge

8.3 Installation Instructions

GKH(09)EB-D6DNA5A/I GKH(12)EB-D6DNA5A/I
GKH(18)EB-D6DNA5A/I GKH(24)EC-D6DNA6A/I

Installation of Cassette Type

1. Before Installation

After receiving the machine, please check for any transport damage. If finding any surface or internal damage, please immediately report to the transport company or equipment company in writing.

After receiving the machine, please check the unit and accessories in reference to the packing list.

Ensure that the model is correct and the machine is in good condition. Please also check if the specification and quantity of accessory parts are correct.

Determine the correct handling route and methods, thus to avoid damaging the unit or causing possible hazard.

For the sake of protection and safety, it is suggested to move the unit with the packaging box. Even though it is not permitted to do like this under special occasions, do not remove the packaging box, thus to avoid loosening or falling during handling.

Confirm if the installing foundation is solid. When this unit is to be installed on the metal section of the building, make sure that the electrical insulation must comply with applicable standards.

Ensure that the place of installation is far from the area where the inflammable or explosive substances are stored, thus to avoid possible explosion or fire due to leakage.

2. Installation Site

Select an installation site where the following conditions are fulfilled and that meets your customer's approval.

(1) Obstruct should be put away from the intake or outlet vent of the indoor unit so that the airflow can be blown through all the room.

(2) Make sure that the installation meets the requirement of the schematic diagram of installation spaces.

(3) Select the place where can stand 4 times of the weight of the indoor unit and would not increase the operating noise and vibration.

(4) The horizontality of the installation place should be guaranteed.

(5) Select the place where is easy to drain out the condensate water, and connect with outdoor unit.

(6) Make sure that there are enough space for care and maintenance, and the height fall between the indoor unit and ground is above 1800mm.

(7) When installing the suspension bolt, check if the installation place can stand 4 times of the weight of the unit. If not, reinforce it before installation.

Note: There will be large amount of greasy dirt accumulated on the fan, heat exchanger and water pump located in the dinning room and kitchen, which would reduce the capacity of the heater exchanger, lead to leakage and abnormal operation of the water pump.

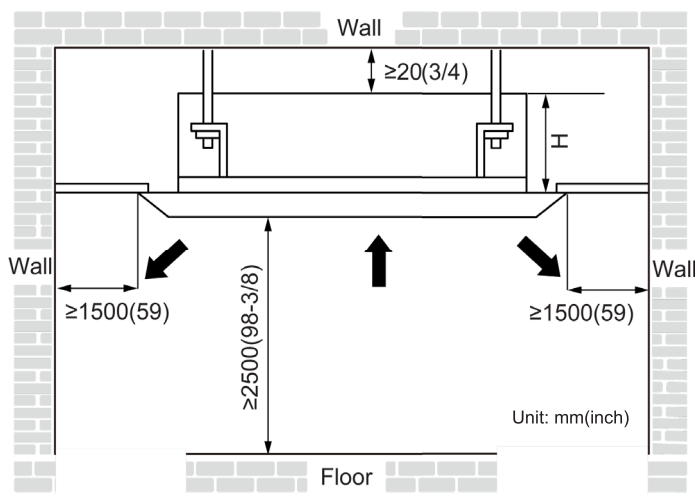

Fig.1

Table 2

Models	H(mm)
GKH(09)EB-D6DNA5A/I	295
GKH(12)EB-D6DNA5A/I	
GKH(18)EB-D6DNA5A/I	
GKH(24)EC-D6DNA6A/I	270

3. Connection Pipe Requirement



The maximum length of the connection pipe is listed in the table below. Do not place the units between which the distance exceeds the maximum length of the connection pipe.

Table 3

Item Model	Size of Fitting Pipe(Inch)		Max. Pipe Length (m)	Max. Height Difference between Indoor Unit and Outdoor Unit (m)	Drainage pipe(Outer Diameter × wall thickness) (mm)
	Liquid	Gas			
GKH(09)EB-D6DNA5A/I GKH(12)EB-D6DNA5A/I	1/4	3/8	30	15	Φ25x1.5
GKH(18)EB-D6DNA5A/I		1/2	35	20	
GKH(24)EC-D6DNA6A/I	1/4	5/8	50	25	

The connection pipe should be insulated with proper waterproof insulating material. The pipe wall thickness shall be 0.5-1.0mm and the pipe wall shall be able to withstand the pressure of 6.0 MPa. The longer the connecting pipe, the lower the cooling and heating effect performs.

4. Electrical Requirement

Electric Wire Size and Fuse Capacity.

Table 4

Idoor Unit	Power Supply	Fuse Capacity	Min. Power Supply Cord
	V/Ph/Hz	A	mm ²
GKH(09)EB-D6DNA5A/I GKH(12)EB-D6DNA5A/I GKH(18)EB-D6DNA5A/I GKH(24)EC-D6DNA6A/I	220V~ 60Hz	5	4x0.75

Notes:

- (1). The fuse is located on the main board.
- (2). Install the disconnect device with a contact gap of at least 3mm in all poles nearby the units (Both indoor unit and outdoor unit).The appliance must be positioned so that the plug is accessible.
- (2). The specifications of the power cable listed in the table above are applied to the conduitguarded multi-wire copper cable (like, YJV copper cable, consisting of PE insulated wires and a PVC cable jacket) used at 40°C and resistible to 90°C (see IEC 60364-5-52). If the working condition changes, they should be modified according to the related national standard.

5 Installing of the Unit

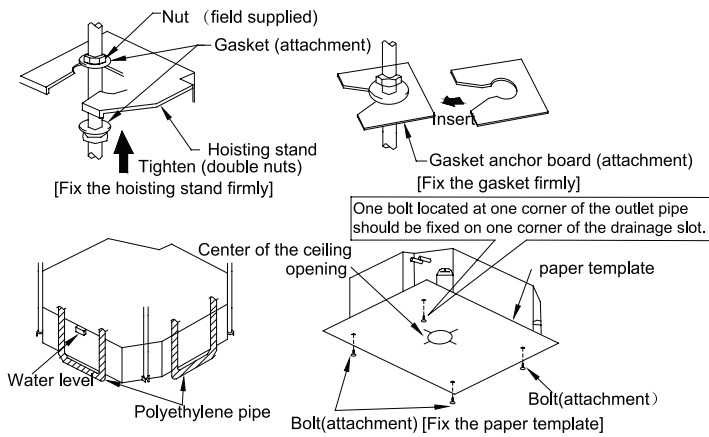

Fig.2

- (1). Install the hoisting stand on the hoisting screw by using nuts and gaskets at both the upper and lower sides of the hoisting stand. To prevent the gasket from breaking off, a gasket anchor board can be helpful.
- (2). Install the paper template on the unit, and fix the drain pipe at the outlet vent
- (3). Adjust the unit to the best position.
- (4). Check if the unit is installed horizontally at four directions. If not, the water pump and the float switch would function improperly and even lead to water leakage
- (5). Remove the gasket anchor board and tighten the nut remained.
- (6). Remove the paper template.

Note:

- 1.Drilling of ceiling opening and installation of air conditioner must be performed by professionals!
- 2.Please refer to the installation cardboard for the dimension of drilling hole of lifting screw of cassette unit.

6 Installing the Suspension Bolts

- (1) Using the installation template, drill holes for bolts (four holes). (Fig.3)
- (2) Install the bolts to the ceiling at a place strong enough to hang the unit. Mark the bolt positions from the installation template. With a concrete drill, drill for 12.7 mm (1/2") diameter holes. (Fig.4)
- (3) Insert the anchor bolts into the drilled holes, and drive the pins completely into the anchor bolts with a hammer.(Fig.5)

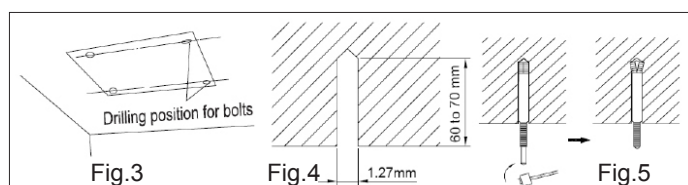

7. Leveling

The water level test must be done after installing the indoor unit to make the unit is horizontal, as shown below.

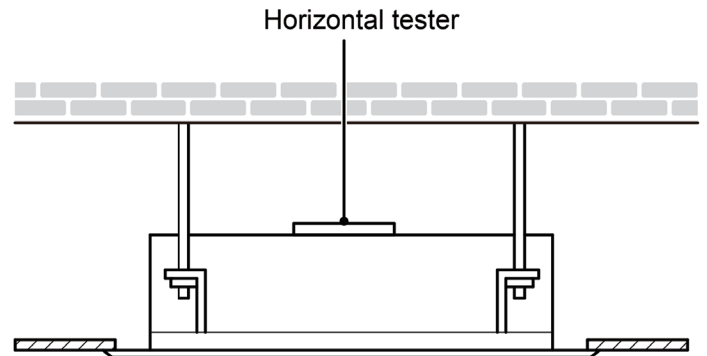

Fig.6

Installation of the Connection Pipe

1. Flare Processing .

- (1). Cut the connection pipe with the pipe cutter and remove the burrs.
- (2). Hold the pipe downward to prevent cuttings from entering the pipe.
- (3). Remove the flare nuts at the stop vave of the outdoor unit and inside the accessory bag of the indoor unit, then insert them to the connection pipe, after that, flare the connection pipe with a flaring tool.
- (4). Check with the flare part is spread evenly and there are no cracks(See Fig.7)

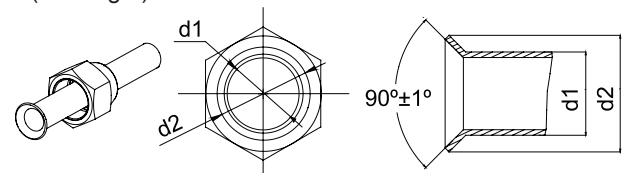

Fig.7

2. Bending Pipes

- (1). The pipes are shaped by your hands. Be careful not to collapse them.

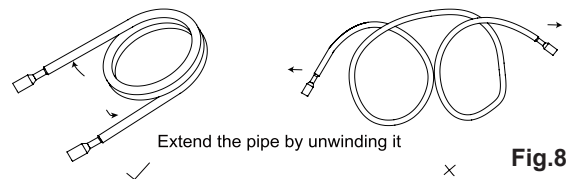

Fig.8

- (2). Do not bend the pipes in an angle more than 90°.

- (3). When pipes are repeatedly bent or stretched, the material will more. Do not bend or stretch the pipes more than three times.

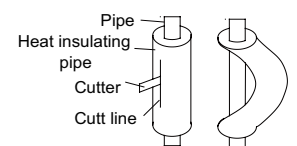

Fig.9

- (4). When bending the pipe, do not bend it as is. The pipe will be collapsed. In this case, cut the heat insulating pipe with a sharp cutter as shown in Fig.9, and bend it after exposing the pipe. After bending the pipe as you want, be sure to put the heat insulating pipe back on the pipe, and secure it with tape.

CAUTION!

- ① . To prevent breaking of the pipe, avoid sharp bends. Bend the pipe with a radius of curvature of 150mm or over.
- ② . If the pipe is bent repeatedly at the same place, it will break.

3. Connecting the Pipe at the Indoor Unit Side

Detach the caps and plugs from the pipes.

CAUTION!

- ① . Be sure to apply the pipe against the port on the indoor unit correctly. If the centering is improper, the flare nut cannot be tightened smoothly. If the flare nut is forced to turn, the threads will be damaged.
- ② . Do not remove the flare nut until the connection pipe is to be connected so as to prevent dust and impurities from coming into the pipe system.

When connecting the pipe to the unit or removing it from the unit, please do use both the spanner and the torque wrench.(Fig.10) When connecting, smear both inside and outside of the flare nut with refrigeration oil, screw it hand tight and then tighten it with the spanner. Refer to Table to check if the wrench has been tightened properly (too tight would mangle the nut and lead to leakage). Examine the connection pipe to see if it leaks, then take the treatment of heat insulation, as shown in the Fig.10. Use the medium-sized sponge to insulate the coupler of the gas pipe.

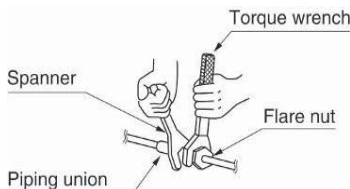
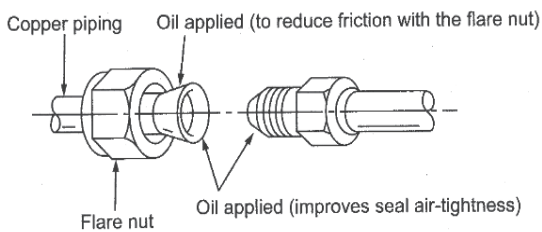
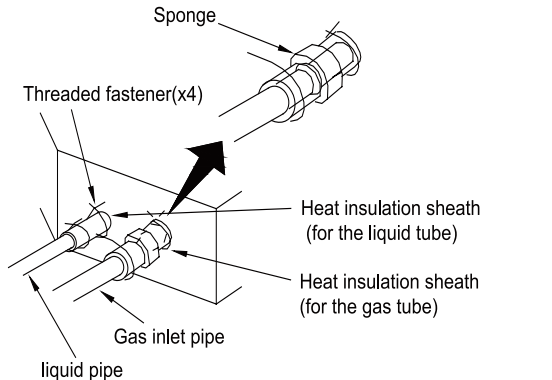

Fig.10

Table 5 Flare nut tightening torque

Pipe Diameter	Tightening Torque
1/4"(Inch)	15-30 (N·m)
3/8"(Inch)	35-40 (N·m)
5/8"(Inch)	60-65 (N·m)
1/2"(Inch)	45-50 (N·m)
3/4"(Inch)	70-75 (N·m)
7/8"(Inch)	80-85 (N·m)

CAUTION!

Be sure to connect the gas pipe after connecting the liquid pipe completely.

4. Connecting the Pipe at the Outdoor Side Unit

Tighten the flare nut of the connection pipe at the outdoor unit valve connector. The tightening method is the same as that as at the indoor side.

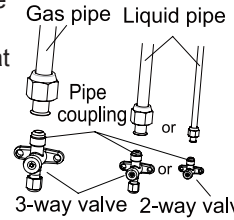

Fig.11

5. Checking the Pipe Connections for Gas Leaking

For both indoor and outdoor unit side, check the joints for gas leaking by the use of a gas leakage detector without fail when the pipes are connected.

6. Heat Insulation on the Pipe Joints (Indoor Side Only)

Stick coupler heat insulation (large and small) to the place where connecting pipes.

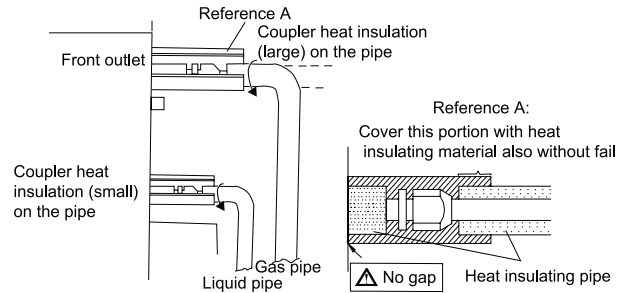

Fig.12

7. Liquid Pipe and Drain Pipe

If the outdoor unit is installed lower than the indoor unit (See Fig.13)

- (1). A drain pipe should be above ground and the end of the pipe does not dip into water. All pipes must be restrained to the wall by saddles.
- (2). Taping pipes must be done from bottom to top.
- (3). All pipes are bound together by tape and restrained to wall by saddles.

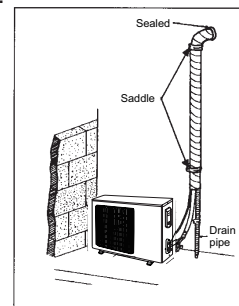

Fig.13

If the outdoor unit is installed higher than the indoor unit (See Fig.14)

- (1). Taping should be done from lower to the upper part.
- (2). All pipes are bound and taped together and also should be trapped to prevent water from returning to the room.
- (3). Restraint all pipes to the wall with saddles.

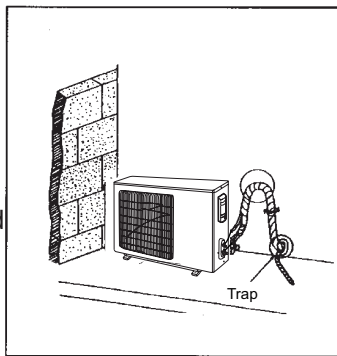

Fig.14

8. Vacuum and Gas Leakage Inspection



Do not purge the air with refrigerants but use a vacuum pump to vacuum the installation! There is no extra refrigerant in the outdoor unit for air purging!

9. Vacuum

- (1). Remove the caps of the liquid valve, gas valve and also the service port.
- (2). Connect the hose at the low pressure side of the manifold valve assembly to the service port of the unit's gas valve, and meanwhile the gas and liquid valves should be kept closed in case of refrigerant leak.
- (3). Connect the hose used for evacuation to the vacuum pump.
- (4). Open the switch at the lower pressure side of the manifold valve assembly and start the vacuum pump. Meanwhile, the switch at the high pressure side of the manifold valve assembly should be kept closed, otherwise evacuation would fail.
- (5). The evacuation duration depends on the unit's capacity, generally, 15 minutes for the 12k units, 20 minutes for the 18k units, 30 minutes for the 24 units. And verify if the pressure gauge at the low pressure side of the manifold valve assembly reads -1.0Mp (-75cmHg), if not, it indicates there is leak somewhere. Then, close the switch fully and then stop the vacuum pump.
- (6). Wait for some time to see if the system pressure can remain unchanged, 3 minutes for the units less than 18k, 5 minutes for the 18K~24k units. During this time, the reading of the pressure gauge at the low pressure side can not be larger than 0.005Mp (0.38cmHg).
- (7). Slightly open the liquid valve and let some refrigerant go to the connection pipe to balance the pressure inside and outside of the connection pipe, so that air will not come into the connection pipe when removing the hose. Note that the gas and liquid valve can be opened fully only after the manifold valve assembly is removed.
- (8). Place back the caps of the liquid valve, gas valve and also the service port.

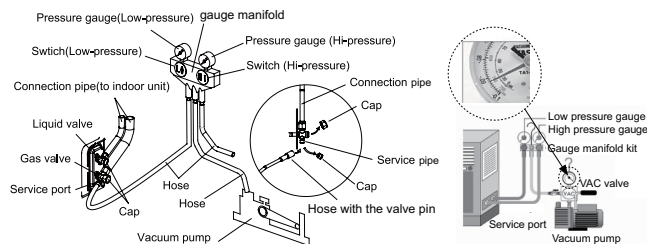

Fig.15

Note: For the large-sized unit, it has the service port for both the gas valve and the liquid valve. During evacuation, it is available to connect two hoses of the manifold valve assembly to two service ports to quicken the evacuating speed.

Installation of the Drain Hose

1. Installation of Drain Piping

- (1). Keep piping as short as possible and slope it downwards at a gradient of at least 1/100 so that air may not remain trapped inside the pipe.
- (2). Keep pipe size equal to or greater than that of the connecting pipe.
- (3). Install the drain piping as shown and take measures against condensation. Improperly rigged piping could lead to leaks and eventually wet furniture and belongings.

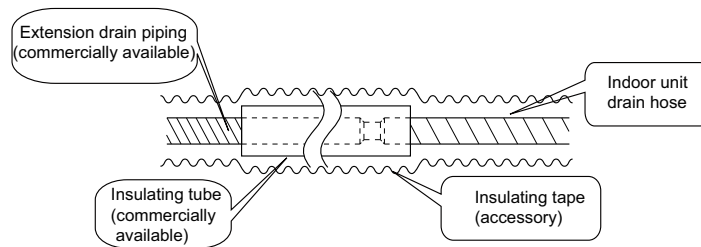
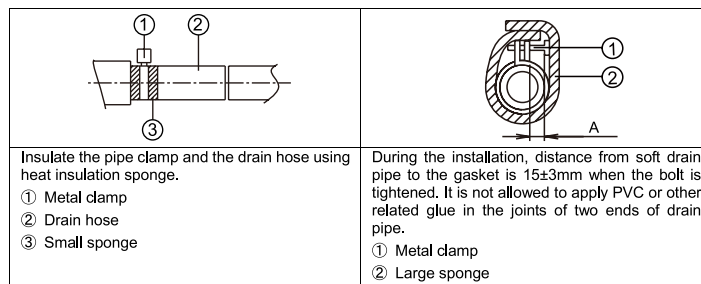

Fig.16

2. Installing the Drain Pipes

- (1). Insert the drain pipe to the drain outlet of the unit and then tighten the clamp securely with tape.
- (2). Connect the extension drain pipe to the drain pipe and then tighten the clamp with tape.



Indoor Unit	A
GKH(09)EB-D6DNA5A/I GKH(12)EB-D6DNA5A/I	≤12mm
GKH(18)EB-D6DNA5A/I	
GKH(24)EC-D6DNA6A/I	≤15mm

(3). When unifying multiple drain pipes, install the pipes as Fig.17. Select converging drain pipes whose gauge is suitable for the operating capacity of the unit.(take the cassette type unit for example)

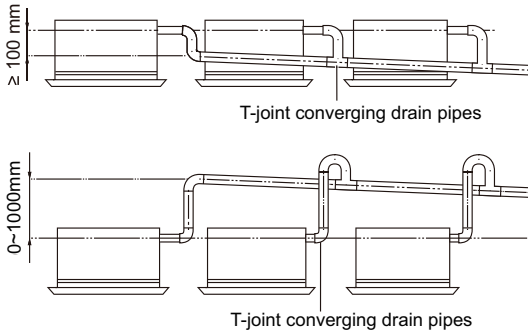

Fig.17

- (4). When the drain hose cannot keep a sufficient gradient, it is necessary to fit a riser pipe(field supplied) to it.
- (5). If the air flow if indoor unit is high, the might cause negative pressure and result in return suction of outdoor air. Therefore, U-type water trap shall be designed on the drainage side of each indoor unit.(Fig.18)
- (6). Install one water trap for each unit.
- (7). Installation of water trap shall consider easy cleaning in the future.

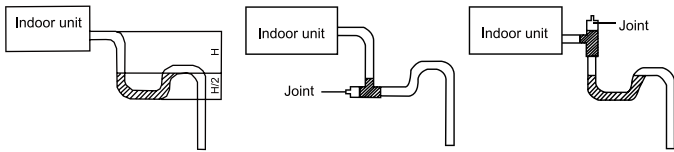

Fig.18

Fig.19

Fig.20

(8). Connection of drainage branch pipe to the standpipe or horizontal pipe of drainage main pipe
The horizontal pipe cannot be connected to the vertical pipe at a same height. It can be connected in a manner as shown below:

- No.1: Attach the 3-way connection of the drainage pipe joint as shown in Fig.21.
- No.2: Attach the drain elbow as shown in Fig.22.
- No.3: Attach the horizontal pipe as shown in Fig.23

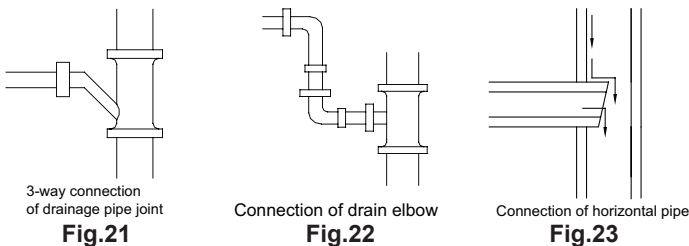

3. Precautions When Doing Riser Piping Work

- (1). Make sure that heat insulation work is executed on the following 2 spots to prevent any possible water leakage due to dew condensation.
 - 1). Connect the drain hose to the drain lift pipe, and insulate them.

2). Connect the drain hose to the drain outlet on the indoor unit, and tighten it with the clamp.

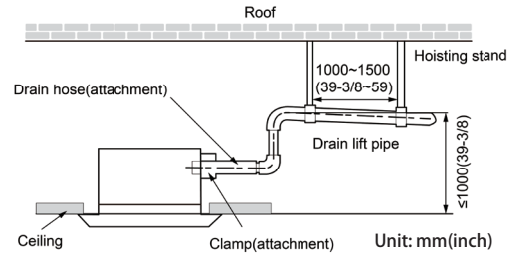

Fig.24

(2). Secure a downward gradient of 1/100 or more for the drain pipe. To accomplish this, mount supporting brackets at an interval of 1 -1.5 m.

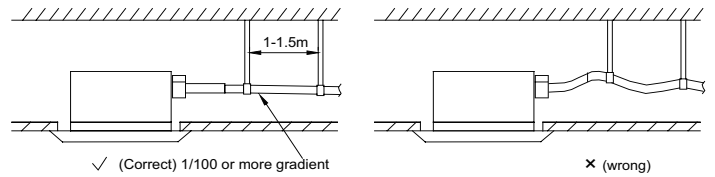

Fig.25

(3). The incline of attached drain hose should be 75 mm or less so that the drain outlet does not have to withstand additional force.

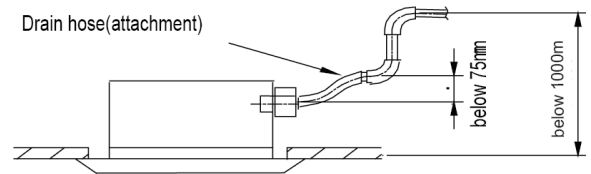

Fig.26

4. Check Drainage

After the pipeline work is finished, check whether the drainage can go smoothly.

- (1). Add slowly about 1L of water into the water tray. After the electric circuit is completed, check the drainage condition during refrigerating operation.

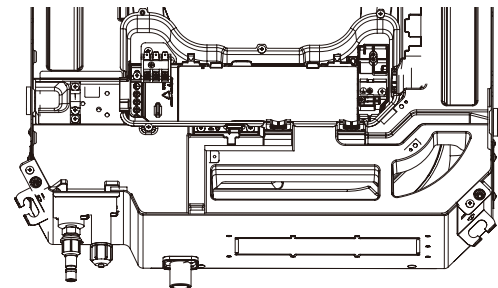

Fig.27

Single-phase units(09/12/18/24K)

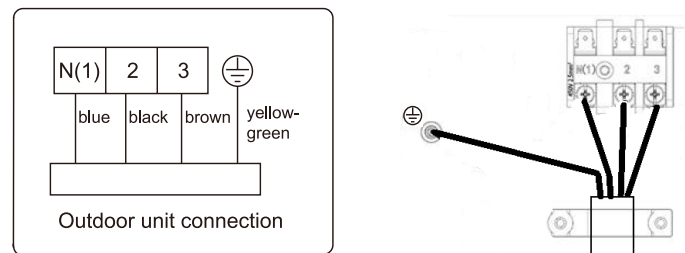

Fig.28

Installing the Front Panel

As shown below, take off the 4 corner covers from the front panel and loose the hexagon screw bolts on the 4 fasteners to the maximum. The position marked with "PIPING SIDE" on the front panel will direct right at the pipe mouth of the indoor unit.

(1) Temporarily hang the 4 fasteners on the corresponding hooks of the main body of the indoor unit (Do not let the conducting wires get involved into the sealing material).

(2) Screw in the hexagon screws beneath the 4 fasteners by about 15mm (Front panel will rise).

(3) As shown below, turn the front panel according to the arrow direction so that the front panel can be well connected with the ceiling.

(4) Screw up the screws until the thickness of the sealing material between the front panel and the ceiling is 5-8mm.

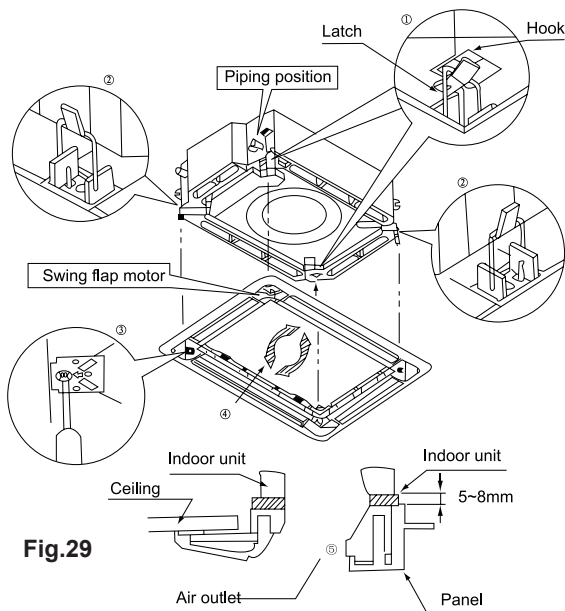

Fig.29

NOTES:

(1) Improper screw looseness will lead to the following problem.

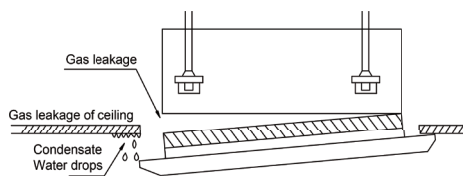

Fig.30

(2) After the screws are tightened, if there is still a gap between the ceiling and the decorative front panel, adjust the height of the unit again (as shown below).

If the lifting level of indoor unit and the drain pipeline won't be affected, it's fine to adjust the height of indoor unit through the holes on the corners of the front panel.

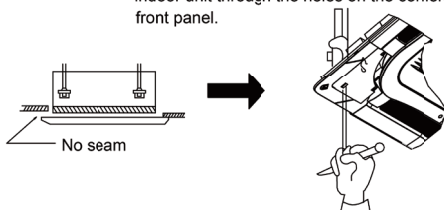

Fig.31

(3) After installing the front panel, make sure there's no gap between the unit and the front panel.

(4) Circuit of the decorative front panel.

(5) Connect the front panel to the main body through the corresponding slots. Match the slots according to their different size.

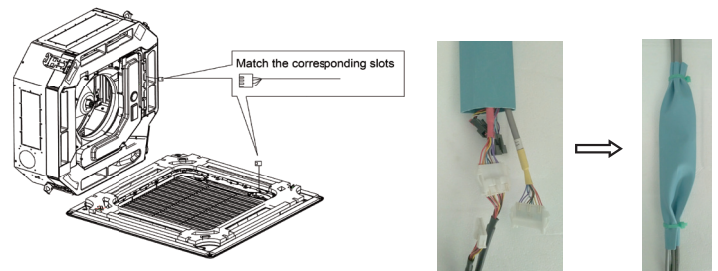

Fig.32

WARNING!

After installing the panel, the insulated protective cover with the thickness of 1mm shall be used to wrap the wiring terminal. Tighten the insulated glue cover on both sides with bonding tie to fix it.

Electrical Wiring

1. Wiring Precautions

WARNING!

- ① . Before obtaining access to terminals, all supply circuits must be disconnected.
- ② . The rated voltage of the unit is as shown as Table 4
- ③ . Before turning on, verify that the voltage is within the 198~264V range (for single phase unit) or 342~457V range (for three-phase unit).
- ④ . Always use a special branch circuit and install a special receptacle to supply power to the air conditioner.
- ⑤ . The special branch circuit breaker is installed in the permanent wiring. Always use a circuit that can trip all the poles of the wiring and has an isolation distance of at least 3mm between the contacts of each pole.
- ⑥ . Perform wiring work in accordance with standards so that the air conditioner can be operated safely and positively.
- ⑦ . Install a leakage special branch circuit breaker in accordance with the related laws and regulations and electric company standards.

CAUTION!

- ① . The power source capacity must be the sum of the air conditioner current and the current of other electrical appliances. When the current contracted capacity is insufficient, change the contracted capacity.
- ② . When the voltage is low and the air conditioner is difficult to start, contact the power company to raise the voltage.

2. Electrical Wiring

(1). For solid core wiring (Fig.33)

1). Cut the wire end with a wire cutter or wire-cutting pliers, then strip the insulation about 25 mm (15/16") .

2). Using a screwdriver, remove the terminal screw(s) on the terminal board.

3). Using pliers, bend the solid wire to form a loop suitable for the terminal screw.

4). Shape the loop wire properly, place it on the terminal board and tighten securely with the terminal screw using a screwdriver.

(2). For strand wiring (Fig.33)

- 1). Cut the wire end with a wire cutter or wire-cutting pliers, then strip the insulation about 10 mm (3/8").
- 2). Using a screwdriver, remove the terminal screw (s) on the terminal board.
- 3). Using a round terminal fastener or pliers, securely clamp a round terminal to each stripped wire end.
- 4). Position the round terminal wire, and replace and tighten the terminal screw with a screwdriver.(Fig.34

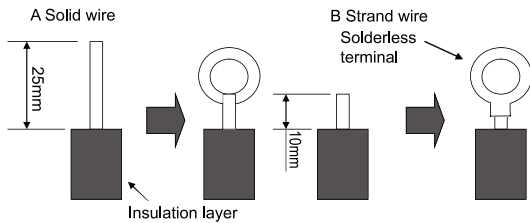

Fig.33

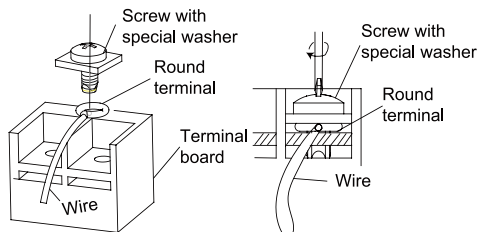

Fig.34

- (3). How to fix connection cord and power cord by cord clamp
After passing the connection cord fasten it with the cord clamp.
(Fig.35

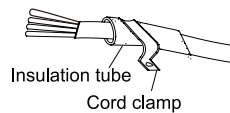

Fig.35

(4). Electric wiring of indoor unit side

Take off the electric box cover from the sub-assembly of electric box. Then connect the wires.

Connect the connection wires of indoor unit according to the corresponding marks.

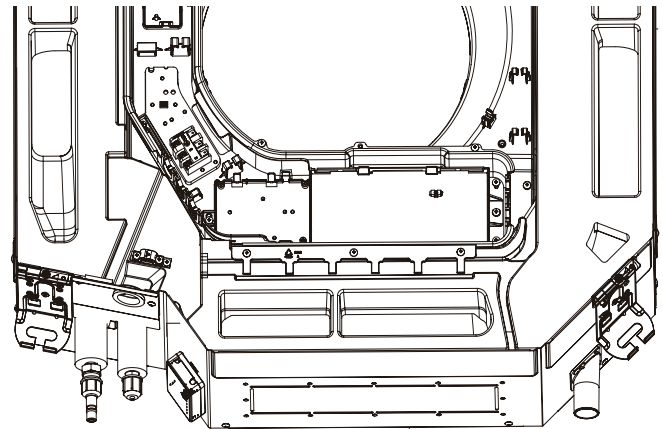

Fig.36

CAUTION!

- ① . Tighten the power cord respectively on the terminal boards with screws. Faulty connection may cause a fire.
- ② . If the power supply are wired incorrectly, the air conditioner may be damaged.
- ③ . Connect the indoor unit connection cord properly based on the corresponding marks as shown in Fig.34.
- ④ . Ground both the indoor and outdoor units by attaching a ground wire.
- ⑤ . Unit shall be grounded in compliance with the applicable local and national codes.

WARNING!

- ① . Before starting work, check that power is not being supplied to the indoor unit and outdoor unit.
- ② . Match the terminal block numbers and connection cord colors with those of the indoor unit side.
- ③ . Erroneous wiring may cause burning of the electric parts.
- ④ . Connect the connection cords firmly to the terminal block. Imperfect installation may cause a fire.
- ⑤ . Always fasten the outside covering of the connection cord with cord clamps. (If the insulator is not clamped, electric leakage may occur.)
- ⑥ . Always connect the ground wire.

Installation of Contrrollers

Refer to the Installation Manual of the controller for more details.

Test Running

8.9.1 Trial Operation and Testing

- (1). The meaning of error codes as shown below:

Standard Fittings

- (1) The appliance shall not be installed in the laundry.
- (2) The location should be able to withstand the weight of unit.
- (3) The water can be drained conveniently from drainage pipe.
- (4) There should be no obstruction near air inlet and air outlet.
- (5) Follow the installation distance required in the fig below to ensure sufficient space for maintenance.
- (6) The installation location should be far from heat sources, flammable or explosive gas or smog spread in the air.
- (7) The indoor unit, outdoor unit, power cord and connection electricity wire should be at least 1m from television and radio in order to prevent interference and noise. (Even though 1m distance is ensure, there may be noise if the electric wave is too strong.)

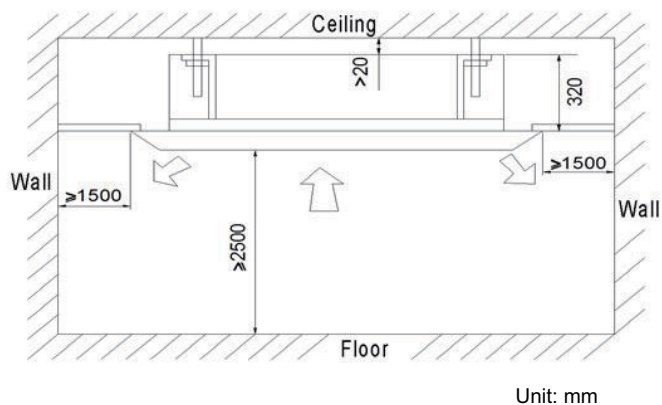

CAUTION!

- (1) The unit shall be installed in accordance with national standards or local regulations.
- (2) Only qualified personnel can carry out installation work, please contact with local dealer before installation.
- (3) Make sure all the installation work completed before energizing.

Wiring Requirement

Dimension of power cord and capacity of air switch.

Mode	Power Cord Size	Minimum Sectional Area of Power Cord mm ²
	V/Ph/Hz	
GKH(09)DA-D6DNA1A/I	220V~ 60Hz	4x1.0
GKH(12)DA-D6DNA1A/I		
GKH(18)DA-D6DNA1A/I		
GKH(20)DA-D6DNA1A/I		

CAUTION!

- (1) An all-pole disconnection switch having a contact separation of at least 3mm in all poles should be connected in fixed wiring.
- (2) The circuit breaker and power cord specification in above sheet is based on max power (max current) of the unit.
- (3) The power cord specification in above sheet is based on ambient temperature of 40°C.
- (4) The circuit breaker specification in above sheet is based on ambient temperature of 40°C. If the working condition is different, please adjust it according to the specification sheet of circuit breaker.

Indoor Unit Installation

(1) Ceiling Opening Dimension and Suspension Bolt Position.

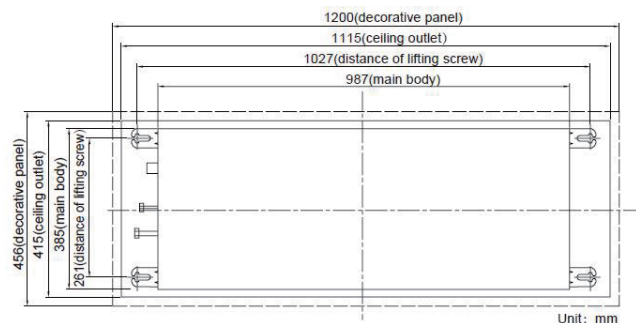

Suspend the Indoor Unit

(1) Drill bolt holes and install bolts.

- ① Stick the reference cardboard on the installation position; drill 4 holes according to the hole site on the cardboard as shown in Fig 1; diameter of drilling hole is according to the diameter of expansion bolt and the depth is 60-70mm, as shown.

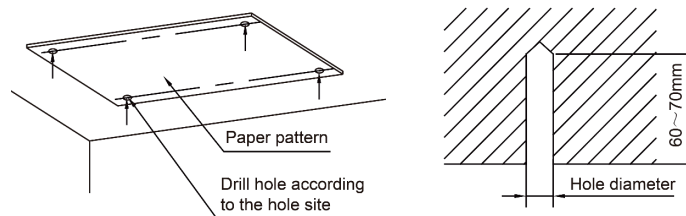

- ② Insert the M10 expansion bolt into the hole and then knock the nail into the bolt, as shown.

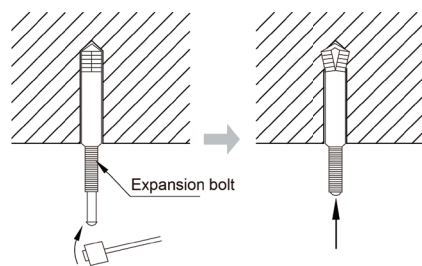

The length of bolt depends on the installation height of the unit, bolts are field supplied.

(2) Install the indoor unit temporarily.

Assemble suspension bolt on the expansion bolt, attach the hanger bracket to the suspension bolt. Be sure to fix it securely by using a nut and washer from upper and lower sides of the hanger bracket. The washer fixing plate will prevent the washer from falling.

(3) The usage of paper pattern.

Refer to paper pattern of installation for ceiling opening dimension. The center of ceiling opening is indicated on the paper pattern. Fix the paper pattern to the unit with 4 screws and fix the corners of the waterspout at the drainage pipe by screws.

(4) Adjust the unit to the right position.

(5) Check the level of the unit

The indoor unit is equipped with build-in water pump and float switch, verify the levelness of 4 directions by level gauge or vinyl tube (filled with water) respectively.

- (6) Remove the washer locating plate and then tighten the nut on it.
- (7) Remove the paper pattern.

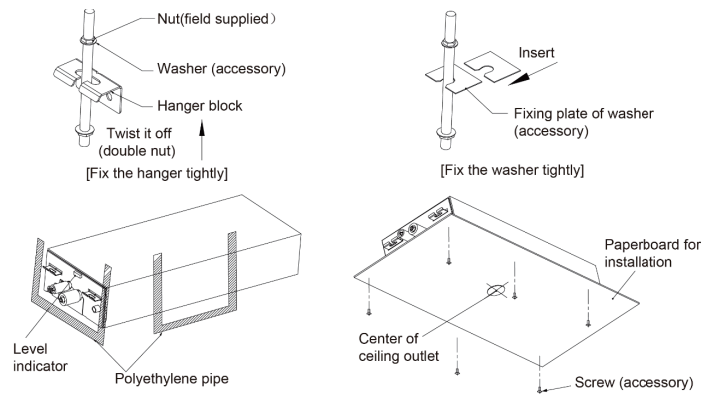

Refrigerant Pipe Connection

- (1) Aim the flaring port of copper pipe at the center of screwed joint and then tighten the flaring nut with hand as shown.
- (2) Tighten the flaring nut with torque wrench.

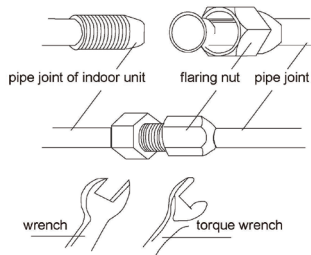

Torque for tightening nut

Pipe diameter(inch)	Torque(N·m)
Φ1/4	15~30
Φ3/8	35~40
Φ1/2	45~50
Φ5/8	60~65

- (3) Use pipe bend when bending the pipe and the bending angle should not be too small.
- (4) Wrap the connection pipe and joint with sponge and then tie them firmly with tape.

Drainage Pipe Installation and Drainage System Testing

1. Notice for Installation of Drain Pipe

- (1) It is not allowed to connect the condensate drain pipe into waste pipe or other pipelines which are likely to produce corrosive or peculiar smell to prevent the smell from entering indoors or corrupt the unit.
- (2) It is not allowed to connect the condensate drain pipe into rain pipe to prevent rain water from pouring in and cause property loss or personal injury.
- (3) Condensate drain pipe should be connected into special drain system for air conditioner.
- (4) The drainage pipe should be short and the gradient downwards should be at least 1%~2% in order to drain condensation water smoothly.
- (5) The diameter of drainage hose should be bigger or equal to the diameter of drainage pipe joint.
- (6) Install drainage pipe according to the following fig and arrange insulation to the drainage pipe. Improper installation may lead to water leakage and damp the furniture and other things in the room.
- (7) You can buy normal hard PVC pipe used as the drainage pipe. During connection, insert the end of PVC pipe into the drainage hole and then tighten it with drainage hole and wire binder. Can't connect the drainage hole and drainage hole with glue.

- (8) When the drainage pipelines are used for several units, the position of pipeline should be about 100mm lower than the drainage port of each unit. In this case, thicker pipes should be applied.

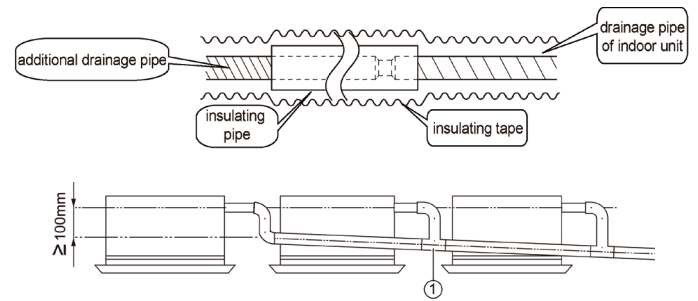

2. Drainage Pipe Installation

- (1) Drainage pipe should have the same diameter or larger diameter than the connecting pipes (PVC pipe, outside diameter 25mm, thickness≥1.5mm).
- (2) Keep drainage pipe short and sloping downwards at a gradient of at least 1% for preventing forming air bubbles.
- (3) If the gradient of drainage pipe could not meet the installation requirements, raising pipe should be applied.
- (4) Insert the drainage hose into drain socket, tighten the metal clamp securely.
- (5) Warp the sealing pad over drain hose and metal clamp for heat insulation.
- (6) Make sure to perform insulation work for all drainage piping in order to prevent any possible water drop due to dew condensation.
- (7) Apply the suitable diameter for converging drainage pipe according to the operating capacity of the unit.

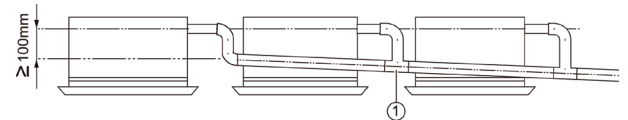

① -drainage pipes assembled by T-shaped joints

- (8) The installation height of raising pipe for drainage should be lower than B. The gradient from raising pipe towards drainage direction should be at least 1%~2%. If the raising pipe is vertical with the unit, the raising height should be less than C.

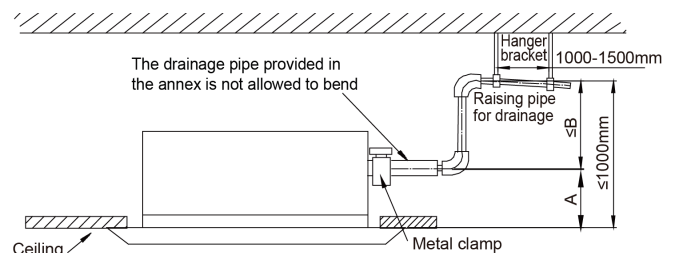

model	A(mm)	B(mm)	C(mm)
All models	100	900	850

(9) Drain pipes should have a downward slope of at least 1%~2%, in order to prevent pipes from sagging, install hanger bracket at intervals of 1000~1500mm.

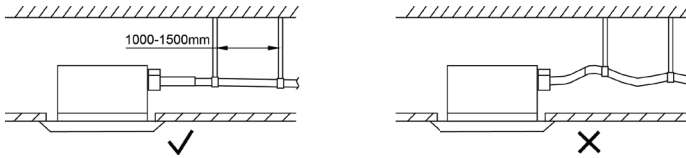

3. Testing of Drain Piping

After piping work is finished, check if drainage flows smoothly. Shown in the Fig 4.3.5, Add approximately 1liter of water slowly into the drain pan and check drainage flow during COOL running.

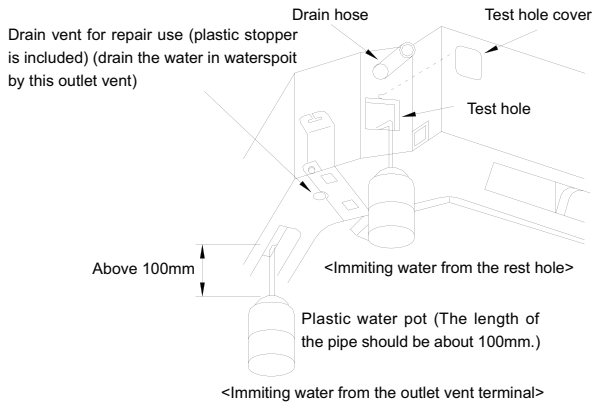

4. Panel Installation

Notices for Installation

(1) Improper decorative panel installation could cause the following problem.

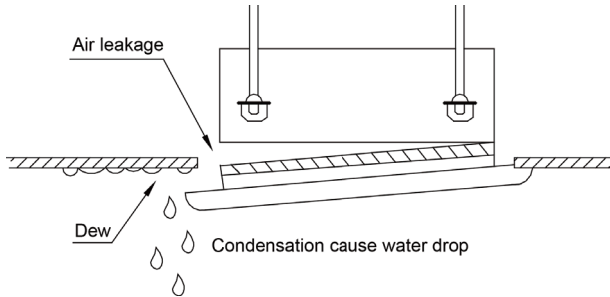

(2) Ensure that it's clearance-free between decoration panels and ceiling board after installation, if not, please adjust the body position.

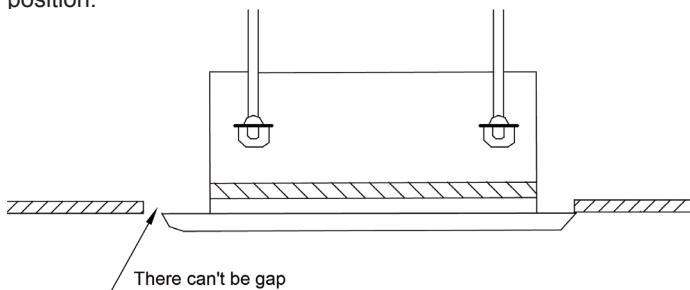

(3) Connect the decoration panel terminals (Female) to body terminals (male) as shown

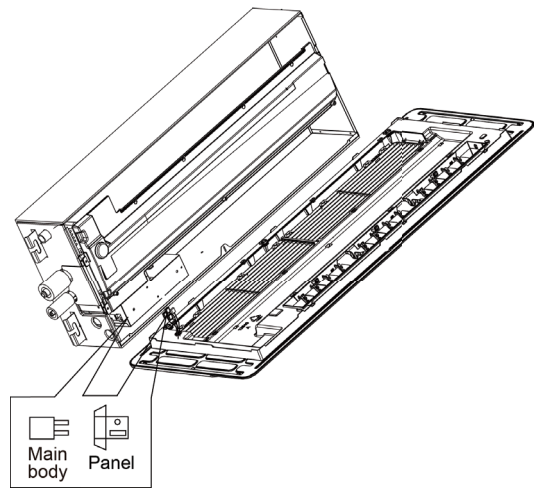

Panel Installation

- (1) Remove the grille from the panel, and then open the horizontal louver.
- (2) Aim the screw hole on panel at the corresponding screw hole on main unit.
- (3) Screw up the screws on corresponding holes and then install the corresponding screw cover.
- (4) Close the horizon lover, connect the butt terminal and arrange the wires.
- (5) Install the grille.

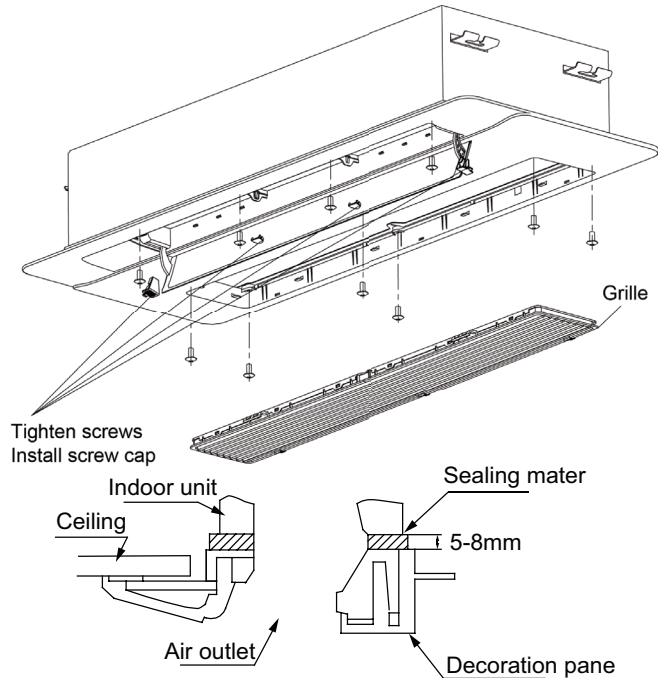

5. Wired Controller Installation

Wired controller is optional accessory. If wired controller is needed, please contact your local dealer and install the wired controller according to the instruction manual.

CAUTION!

Do perform the commissioning operation before first use, automatic addressing or other settings, please refer to the manual of ODU.

Wiring Precautions

⚠ WARNING!

- (1) Before obtaining access to terminals, all supply circuits must be disconnected.
- (2) The rated voltage of the unit is as shown as Table 1. wiring could cause malfunction or even damage the unit.
- (3) Before turning on, verify that the voltage is within the 198~264V range(for single phase unit) or 342~457V range (for three-phase unit).
- (4) Always use a special branch circuit and install a special receptacle to supply power to the air conditioner.
- (5) The special branch circuit breaker is installed in the permanent wiring. Always use a circuit that can trip all the poles of the wiring and has an isolation distance of at least 3mm between the contacts of each pole.
- (6) Perform wiring work in accordance with standards so that the air conditioner can be operated safely and positively.
- (7) Install a leakage special branch circuit breaker in accordance with the related laws and regulations and electric company standards.

⚠ CAUTION!

- (1) The power source capacity must be the sum of the air conditioner current and the current of other electrical appliances. When the current contracted capacity is insufficient, change the contracted capacity.
- (2) When the voltage is low and the air conditioner is difficult to start, contact the power company to raise the voltage.

1. Electrical Wiring

(1) For solid core wiring.

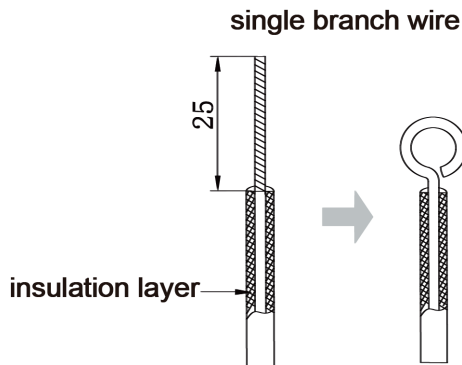

- ① Cut the wire end with a wire cutter or wire-cutting pliers, then strip the insulation about 25mm (15/16") .
- ② Using a screwdriver, remove the terminal screw(s) on the terminal board
- ③ Using pliers, bend the solid wire to form a loop suitable for the terminal screw.
- ④ Shape the loop wire properly, place it on the terminal board and tighten securely with the terminal screw using a screwdriver.

(2) For strand wiring

multiple twisted wires

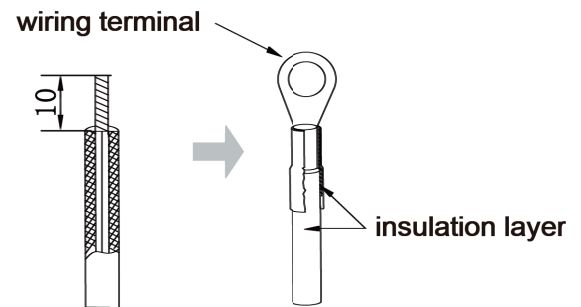

- ① Cut the wire end with a wire cutter or wire-cutting pliers, then strip the insulation about 10mm (3/8").
- ② Using a screwdriver, remove the terminal screw (s) on the terminal board.
- ③ Using a round terminal fastener or pliers, securely clamp a round terminal to each stripped wire end.
- ④ Position the round terminal wire, and replace and tighten the terminal screw with a screwdriver

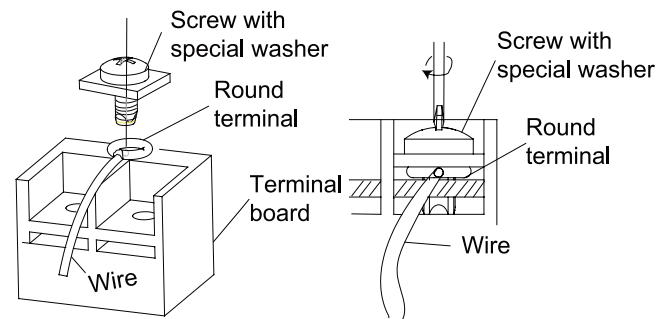

(3) How to fix connection cord and power cord by cord clamp.
After passing the connection cord fasten it with the cord clamp.

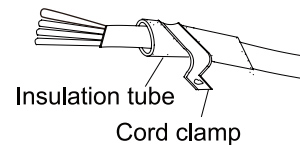

⚠ WARNING!

- ① Before starting work, check that power is not being supplied to the indoor unit and outdoor unit.
- ② Match the terminal block numbers and connection cord colors with those of the indoor unit side.
- ③ Erroneous wiring may cause burning of the electric parts.
- ④ Connect the connection cords firmly to the terminal block. Imperfect installation may cause a fire.
- ⑤ Always fasten the outside covering of the connection cord with cord clamps. (If the insulator is not clamped, electric leakage may occur.)
- ⑥ Always connect the ground wire.

(4) Electric wiring between the indoor and outdoor units
gle-phase units(09~20K)

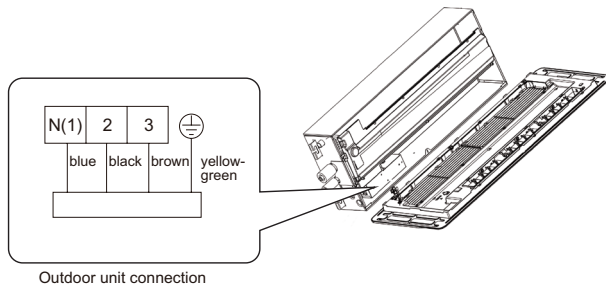

(5) Electric wiring of indoor unit side.

move the electric box cover from the electric box sub-assy and then connect the wire.

CAUTION!

- ① Tighten the power cord respectively on the terminal boards with screws. Faulty connection may cause a fire.
- ② If the power supply are wired incorrectly, the air conditioner may be damaged.
- ③ Connect the indoor unit connection cord properly based on the corresponding marks as shown.

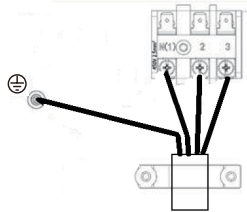

- ④ Ground both the indoor and outdoor units by attaching a ground wire.
- ⑤ Unit shall be grounded in compliance with the applicable local and national codes.

2. Installation of Controllers

Refer to the Installation Manual of the controller for more details.

Routine Maintenance

WARNING!

- ① Do not turn off the unit and cut off the main power supply when cleaning the air conditioner to avoid electric shock or injury.
- ② Stand at solid table when cleaning the unit.
- ③ Do not clean the unit with hot water whose temperature is higher than 45°C to prevent fade or deformation.
- ④ Do not dry the filters by fire, or it may catch fire or become deformed.
- ⑤ Clean the filter with a wet cloth dipped in neutral detergent.
- ⑥ Please contact after-sales service staff if there is abnormal situation.

1. Cleaning of Filter

- (1) Remove the filters from inlet of IDU. Use a vacuum cleaner to remove dust. If the filters are dirty, wash them with warm water and mild detergent, and dry the filters in the shade.
- (2) If the unit used in the environment with much dust, please clean it regularly. (Usually once every two weeks).

2. Maintenance before the Seasonal Use

- (1) Check if the air inlet and air outlet of indoor and outdoor unit are blocked.
- (2) Check if securely grounded.
- (3) Check if all the power cord and communication cable are securely connected.
- (4) Check if any error code displayed after energized.

3. Maintenance after the Seasonal Use

- (1) Set the unit in fan mode for half a day in a sunny day to dry the inner part of unit;
- (2) When the unit won't be used for a long time, please cut off power supply for energy saving; the characters on the wired controller screen will disappear after cutting off the power supply.

9. Maintenance

9.1 Error Code List

Error code	Malfunction name	Possible causes
E6	Communication error between IDU with ODU	Please refer to "Communication Error".
H5	IPM protection	Please refer to "IPM Protection".
L3 LA	Outdoor fan error	<ol style="list-style-type: none">1. Motor or motor wire is damaged;2. Main board of ODU is damaged;3. The fan blade is clogged or loose.
H6	Operating error of IDU motor	<ol style="list-style-type: none">1. Motor terminal is not well connected;2. The motor is damaged;3. Main board of IDU is damaged.
HC	PFC protection	<ol style="list-style-type: none">1. Main board of ODU is damaged;2. Poor power grid quality, with oscillation or significant fluctuations in AC input voltage;3. Unreliable connections of the air conditioner's power plug, terminal board, or reactor, leading to arcing;4. Excessive dirt on indoor and outdoor heat exchangers or blockage of air outlets.
H7	Compressor out of step	<ol style="list-style-type: none">1. Abnormal power supply voltage;2. Condenser or evaporator is dirty or clogged;3. Inlet and outlet air of indoor unit or outdoor unit is not smooth;4. System piping blockage, valves are not open;5. Excessive refrigerant causing excessive system pressure;6. Poor wiring contact;7. Main board is damaged;8. Compressor is damaged; Please refer to "Compressor out of step".

Error code	Malfunction name	Possible causes
F0	Refrigerant lack protection, refrigerant circulation stop protection	<ol style="list-style-type: none"> 1. The connection pipe between the IDU and ODU is damaged or the connection point is aged and loose, leading to refrigerant leakage; 2. The liquid valve / air valve is aged and damaged, causing abnormal opening and closing control, which leads to pipeline blockage; 3. The temperature sensor is damaged or aged, resulting in inaccurate temperature sampling and false error reporting.
PH	High DC bus voltage	<ol style="list-style-type: none"> 1. The AC supply voltage is too high, for example, the AC supply voltage exceeds 300V; 2. Poor power quality, with abnormal oscillation in the AC supply voltage; 3. The main board is damaged.
PL	Low DC bus voltage	<ol style="list-style-type: none"> 1. AC power supply voltage is too low, for example, the AC power supply voltage is less than 90V; 2. Abnormal unit wiring, such as loose connection wires; 3. Main board of outdoor unit is damaged;
E8	High-temperature protection	<p>Cooling:</p> <ol style="list-style-type: none"> 1. The condenser of the outdoor unit is dirty or clogged, leading to poor heat exchange; 2. Insufficient space or obstacles at the air inlet and outlet of the outdoor unit cause poor air circulation; 3. The fan blade of the outdoor unit is broken, falling off or the motor is damaged; 4. The temperature sensor of the outdoor unit condenser is damaged, or the main board is damaged, leading to inaccurate temperature sampling. <p>Heating:</p> <ol style="list-style-type: none"> 1. The indoor unit evaporator is dirty or clogged, leading to poor heat exchange; 2. Insufficient space or obstructions at the air outlets of the indoor unit cause poor air intake and exhaust; 3. The fan blade of the outdoor unit is broken, falling off; 4. The temperature sensor of the indoor unit evaporator is damaged, or the main board is damaged, leading to inaccurate temperature sampling.

Error code	Malfunction name	Possible causes
E5	Jumper cap error	<ol style="list-style-type: none"> 1. The jumper cap of indoor unit is not installed, or the jumper cap is not properly installed; 2. The jumper cap has poor contact and is not properly installed.
F1	Open/short circuit of indoor temperature sensor	<ol style="list-style-type: none"> 1. Temperature sensor is damaged (refer to attachment "Table 1"); 2. Temperature sensor is not connected or in poor contact.
F2	Open/short circuit of temperature sensor of indoor evaporator	<ol style="list-style-type: none"> 1. Temperature sensor is damaged (refer to attachment "Table 2"); 2. Temperature sensor is not connected or in poor contact.
F3	Open/short circuit of outdoor temperature sensor	<ol style="list-style-type: none"> 1. Temperature sensor is not connected or is damaged; (refer to attachment "Table 1"); 2. Temperature sensor wire is damaged, or is short-circuited to the copper tube or outer case; 3. The main board of ODU is damaged.
F4	Open/short circuit of temperature sensor of outdoor condenser	<ol style="list-style-type: none"> 1. Temperature sensor is not connected or is damaged; (refer to attachment "Table 2"); 2. Temperature sensor wire is damaged, or is short-circuited to the copper tube or outer case; 3. The main board of ODU is damaged.
F5	Open/short circuit of temperature sensor	<ol style="list-style-type: none"> 1. Temperature sensor is not connected or is damaged; (refer to attachment "Table 3"); 2. Temperature sensor wire is damaged, or is short-circuited to the copper tube or outer case; 3. The main board of ODU is damaged.
E5	Overcurrent protection	<ol style="list-style-type: none"> 1. Unstable power supply voltage; 2. Power supply voltage is too low; 3. Condenser or evaporator is dirty or clogged; 4. Inlet and outlet air of IDU or ODU is not smooth; 5. System pipeline is blocked, valves are not open; 6. Excessive refrigerant leads to excessive system pressure; 7. Main board is damaged; 8. Compressor is damaged; <p>Please refer to "Overcurrent protection".</p>

Error code	Malfunction name	Possible causes
H3	Compressor overload protection	<ol style="list-style-type: none"> 1. The connection between the overload connection wire and the main board or the overload protector is unreliable, and the terminal is loose; 2. The overload protector is damaged, under normal circumstances, the impedance at both ends of the test overload protector should be less than 1Ω; 3. The overload connection wire is damaged, resulting in the short circuit of wire; 4. Refrigerant leakage or system blockage; 5. The main board is damaged.
EA	Refrigerant leak alarm	There may be refrigerant leakage in the unit.
FE	Refrigerant sensor error	Service life of refrigerant expires or is damaged.
b7	Open/short circuit of temperature sensor of air valve	<ol style="list-style-type: none"> 1. Temperature sensor is not connected or is damaged; (refer to attachment "Table 2"); 2. Temperature sensor wire is damaged, or is short-circuited to the copper tube or outer case; 3. The main board of ODU is damaged.
b5	Open/short circuit of temperature sensor of liquid valve	<ol style="list-style-type: none"> 1. Temperature sensor is not connected or is damaged; (refer to attachment "Table 2"); 2. Temperature sensor wire is damaged, or is short-circuited to the copper tube or outer case; 3. The main board of ODU is damaged.
E1	System high pressure protection	<ol style="list-style-type: none"> 1. The connection between the wiring and the main board or high-pressure protection switch is unreliable, with loose terminals; 2. The high-pressure protection switch is damaged; under normal circumstances, the impedance between the two ends of the high-pressure protection switch should be less than 1Ω; 3. Abnormalities such as dirt blockage in the condenser or evaporator, poor air circulation, excessive refrigerant, or blockages in the system piping can lead to excessively high system pressure; 4. The main board is damaged.
E3	Low pressure protection/system low pressure protection/compressor low pressure protection	<ol style="list-style-type: none"> 1. Low pressure switch is damaged; 2. System refrigerant leakage.

Error code	Malfunction name	Possible causes
E4	High exhaust temperature protection of compressor	Please refer to "Compressor overload protection".
E7	Mode conflict	When the free match system is faulted, some indoor units will conduct heating mode, while others will conduct cooling, dry mode or air supply mode, causing a mode conflict.
EE	Read EEPROM error	Main board of ODU is damaged.
F0	Refrigerant recovery mode	Recovery of refrigerant. The mode is conducted during maintenance.
HE	Compressor demagnetization protection	<ol style="list-style-type: none"> 1. Main board of ODU is damaged; 2. Compressor is damaged.
L9	High power protection	Please refer to "High temperature protection", "Overcurrent protection", "IPM Protection".
Lc	Startup failure	Please refer to "Startup failure".
Ld	Compressor phase-loss protection	<ol style="list-style-type: none"> 1. Poor wiring contact of compressor; 2. Main board of ODU is damaged; 3. Compressor is damaged.
P5	Over-phase current protection of compressor	Please refer to "IPM Protection".
oE	Undefined ODU error	Please refer to "Undefined ODU error".
P6	Communication error between drive board and main control	<ol style="list-style-type: none"> 1. Poor connection between drive board and main board; 2. Drive board is damaged; 3. Main board of ODU is damaged.
P7	Circuit error of module temperature sensor	Main board of ODU is damaged.

Error code	Malfunction name	Possible causes
P8	High-temperature protection of module	<ol style="list-style-type: none"> 1. Air inlet/outlet of ODU is dirty and clogged; 2. IPM screw of main board is not well installed or the radiator is not well installed, or the main board is damaged.
PF	Error of ambient temperature sensor on drive board	<ol style="list-style-type: none"> 1. Poor contact of ambient temperature sensor of driver board; 2. Error of ambient temperature sensor on drive board.
PU	Capacitor charging error	<ol style="list-style-type: none"> 1. Main board of ODU is damaged; 2. Wiring error of ODU or low power supply voltage.
U1	Compressor phase current detection circuit error	Main board of ODU is damaged.
U2	Compressor phase-loss Protection	<ol style="list-style-type: none"> 1. Poor wiring contact of compressor; 2. Main board of ODU is damaged; 3. Compressor is damaged.
U3	DC bus voltage drop error	Unstable power voltage with large fluctuation.
U5	Current detection error of whole unit	<ol style="list-style-type: none"> 1. The whole unit lacks refrigerant; 2. The circuit on the control board of ODU has failed, the control board shall be replaced.
U7	4-way valve switchover error	<ol style="list-style-type: none"> 1. Power voltage is below AC175V; 2. Loose or broken wires at the four-way valve terminal; 3. Four-way valve is damaged, please replace the four-way valve.
U9	ODU zero-crossing error	Main board of ODU is damaged.
E2	Evaporator anti-freeze protection	It's not an error code, it belongs to the status code during the cooling process.

Error code	Malfunction name	Possible causes
E9	Indoor unit water full protection	<ol style="list-style-type: none"> 1. Water outlet is blocked; Water valve switch connection or detection is abnormal; 2. Main board needle stand connection or detection is abnormal; 3. Water pump is abnormal;
LP	IDU and ODU do not match	Capacity of IDU and ODU do not match.
	Defrosting	It's not an error code, it belongs to the status code during the heating process.

9.2 Procedure of Troubleshooting

E6: Communication Error Between IDU with ODU

1. Communication Error between IDU with ODU

- (1) Cooling/dehumidification: Compressor and outdoor fan stop running;
- (2) Heating: All loads stop running;
- (3) Principle: The indoor and outdoor units cannot establish communication or the established communication data is abnormal.

2. Possible causes

- (1) Electric circuit of main board is damaged;
- (2) Wire connection between IDU and ODU is abnormal, or wire connection between terminal board and main board is abnormal;
- (3) The neutral and live wires are connected in reverse;
- (4) The power grid is abnormal.

3. Troubleshooting

- (1) Check whether the connection wire of the indoor and outdoor units is damaged;
- (2) Check whether the power cord and communication wire of main board of the indoor and outdoor unit are damaged;
- (3) Check whether the wiring sequence is correct, whether the neutral and live wires are connected in reverse, and whether the power cord and communication wire are not connected properly;
- (4) Check whether the LED indicator on the main board of ODU flashes according to the normal rules;
- (5) Check whether the coil of ODU is corroded and short-circuited, causing damage to the main board.

4. Specific troubleshooting steps:

1. Using the after-sales tester GT2A3Ad can identify faults more conveniently and quickly;
 - (1) If it replaces the IDU to communicate with the ODU, and the E6 error occurs, it means the main board of ODU is abnormal;

- (2) If it replaces the ODU to communicate with the IDU, and the E6 error occurs, it means the main board of IDU is abnormal;
- (3) If no E6 error occurs, it means that the connection line between the indoor unit and the outdoor unit is abnormal.

2. Manual Detection

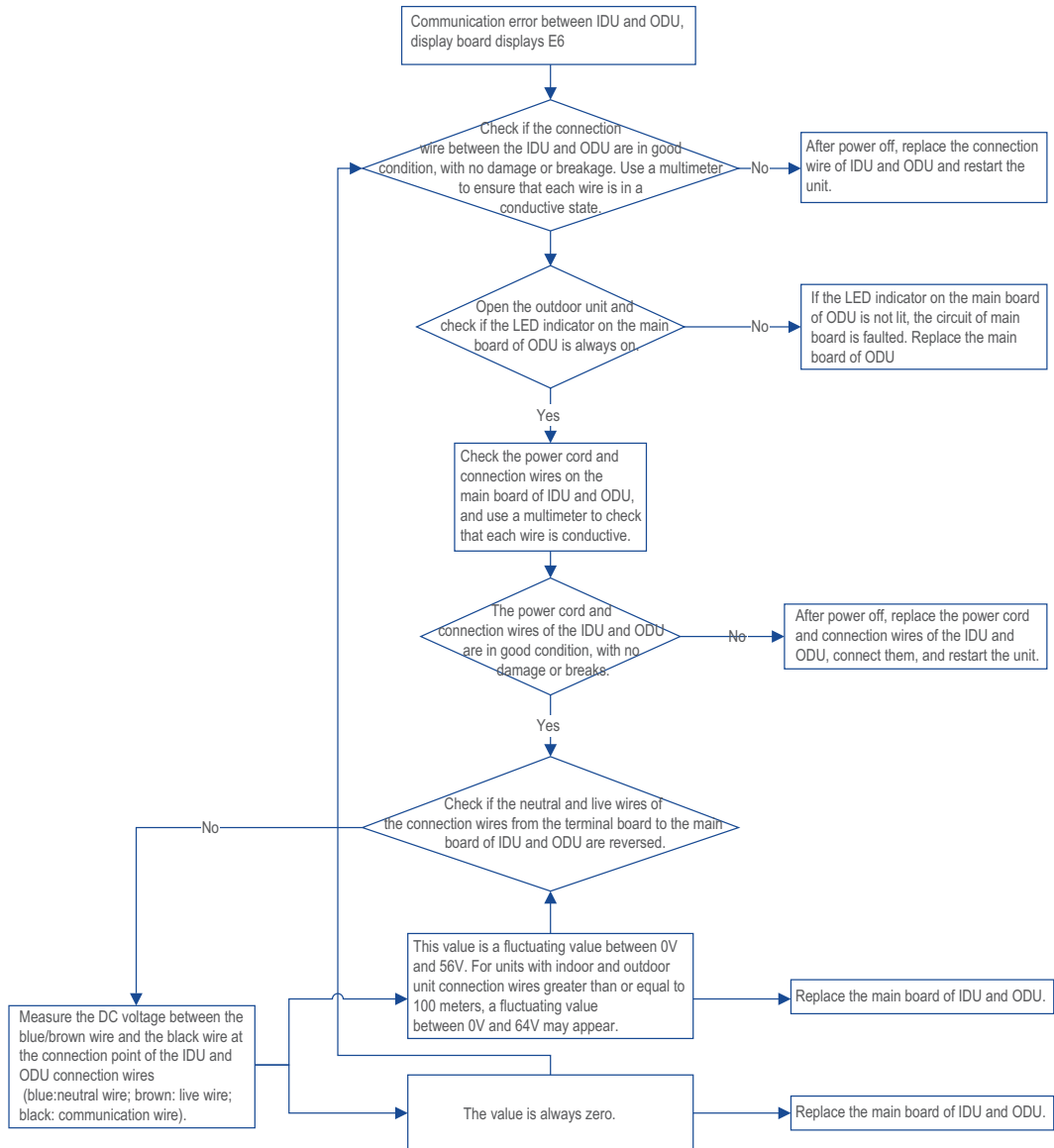

NOTE:

The method for detecting the communication circuit of ODU of the inverter split type unit and the floor standing type terminal unit: disconnect the indoor and outdoor communication wire, and measure the voltage between COM and N on the control board of the ODU (DC gear, about 56V is normal).

H5: IPM Protection

1. Error description

When the compressor is running, detect the current flowing through the compressor control module (IPM). If the current exceeds the set value (the set value varies for different models), an H5 IPM current protection error is reported.

2. Possible causes

- (1) Abnormal power supply voltage;
- (2) Condenser or evaporator is dirty or clogged;
- (3) Inlet and outlet air of IDU or ODU is not smooth;
- (4) System pipe is blocked, valves are not open;
- (5) Excessive refrigerant causing excessive system pressure;
- (6) Poor wire contact;
- (7) Main board is damaged;
- (8) Compressor is damaged.

3. Troubleshooting

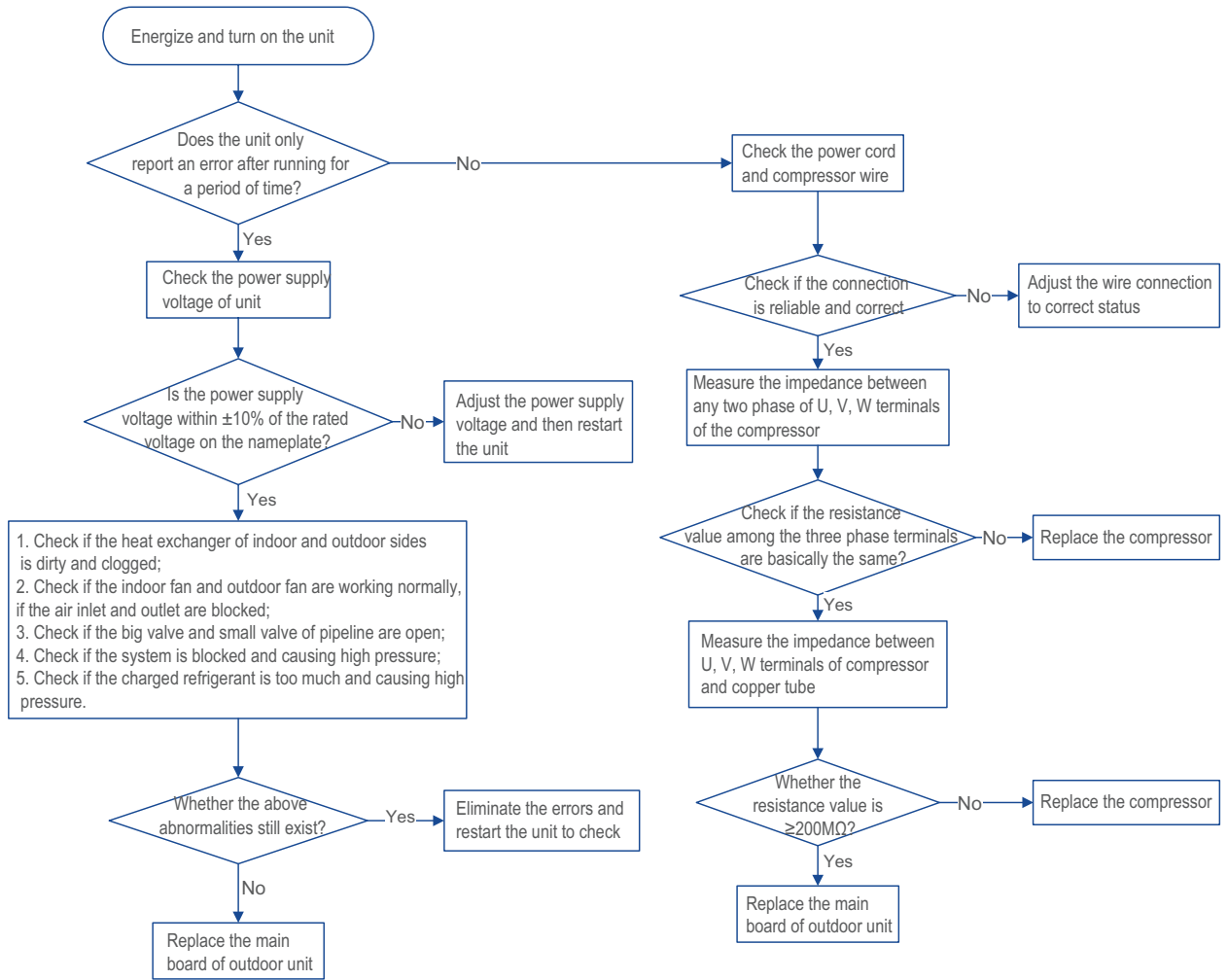

L3: Outdoor Fan Error

1. Outdoor Fan Error

- (1) Cooling/dehumidification: All loads stop running except the indoor fan;
- (2) Heating: All loads stop running;
- (3) Principle: The fan reports a major error every 6 minor errors (such as fan out of step, fan blockage, fan overload, etc.). The unit stops operation and then it will resume operation after 3min. After reporting 6 major errors, L3 will be displayed and the unit can't resume operation;

2. Possible causes

- (1) The wire connection between the fan and the main board is unreliable, with loose terminals;
- (2) The fan wiring is damaged, causing an open circuit;
- (3) The main board is damaged;
- (4) The fan is damaged;
- (5) The fan is blocked or the blades are loose due to external factors.

3. Solutions

Check if the wiring is damaged and if the connection is reliable; check if the fan is damaged; check if the fan is blocked or the blades are loose.

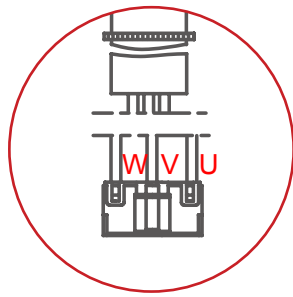
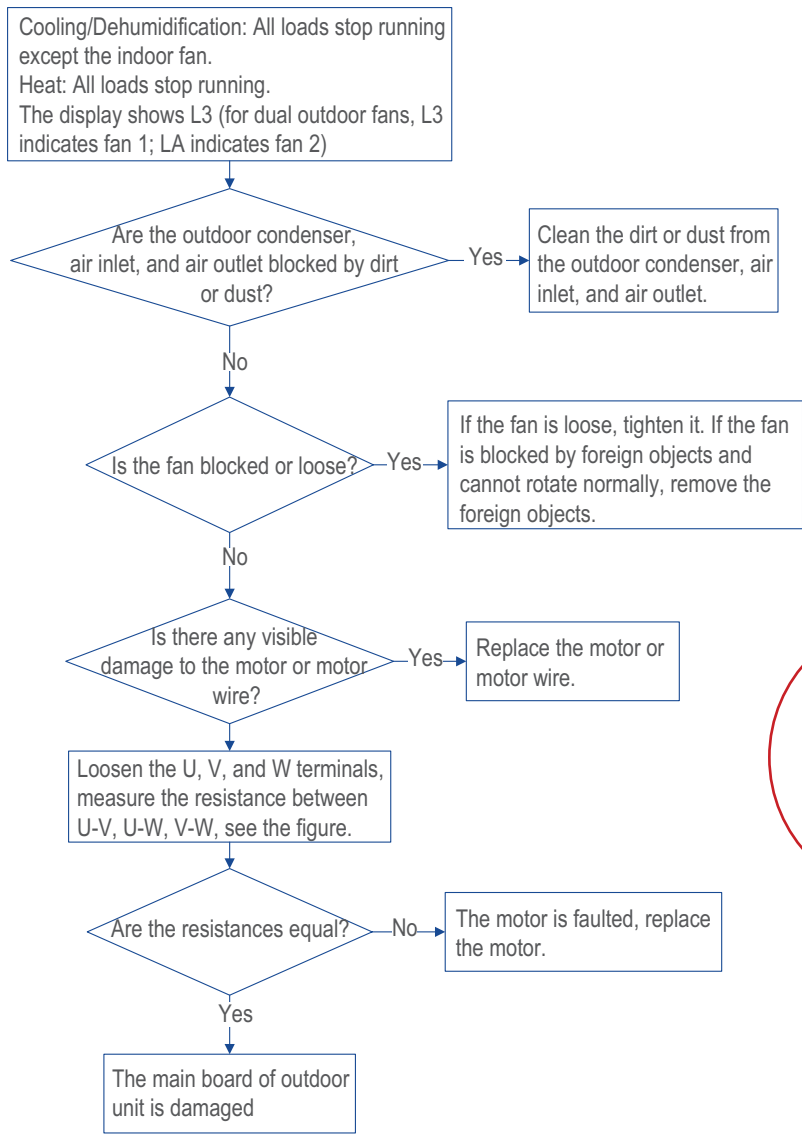

H6: Operating Error of Indoor Unit Motor

Possible causes:

- (1) Motor terminal or feedback terminal is not properly connected;
- (2) Motor is damaged;
- (3) Main board of IDU is damaged.

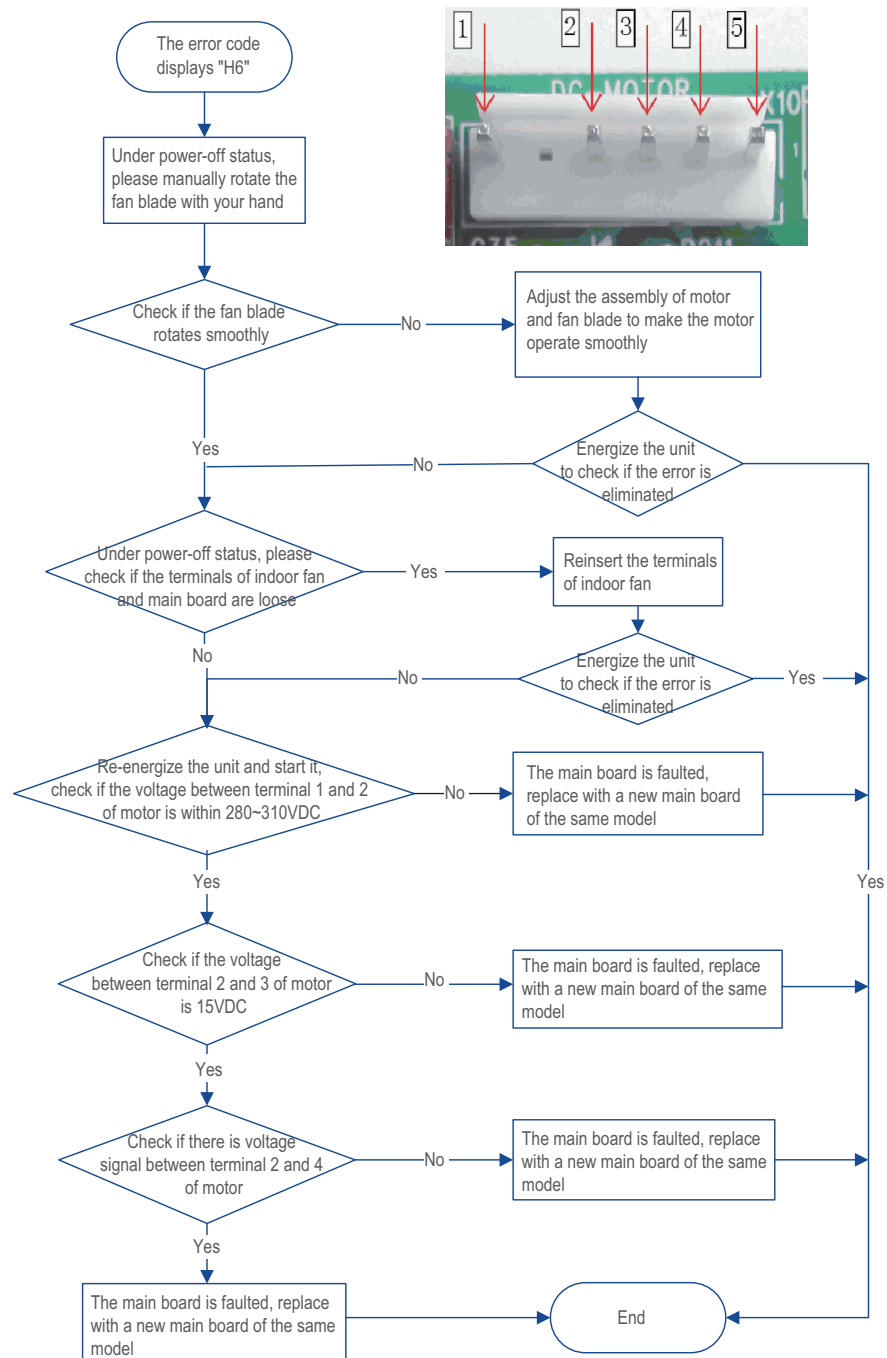

HC: PFC Protection

1. Error description

- (1) Cooling/dehumidification: Compressor and outdoor fan stop running;
- (2) Heating: All loads stop running;
- (3) Principle: The main program detects that the instantaneous input current of the PFC circuit is too high.

2. Possible causes

- (1) The main board of the outdoor unit is damaged;
- (2) The power supply used is an inferior power supply, and the input voltage fluctuates and the current is too large;
- (3) The power cord is not well connected;
- (4) The air inlet of the unit is blocked.

3. Troubleshooting

- (1) Use a multimeter to measure the voltage of the power supply;
- (2) Check whether the connection wire is well connected;
- (3) Check whether the air inlet of the unit is blocked.

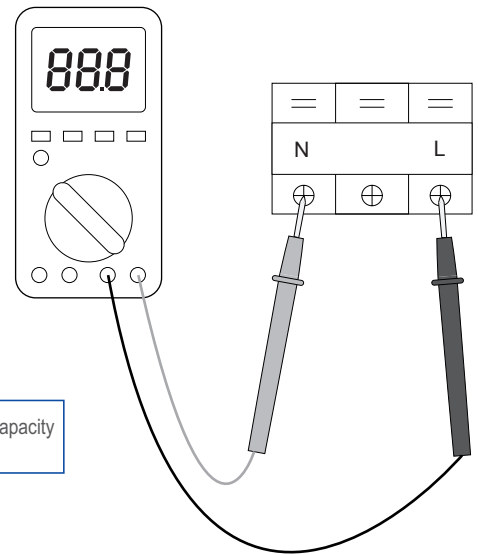
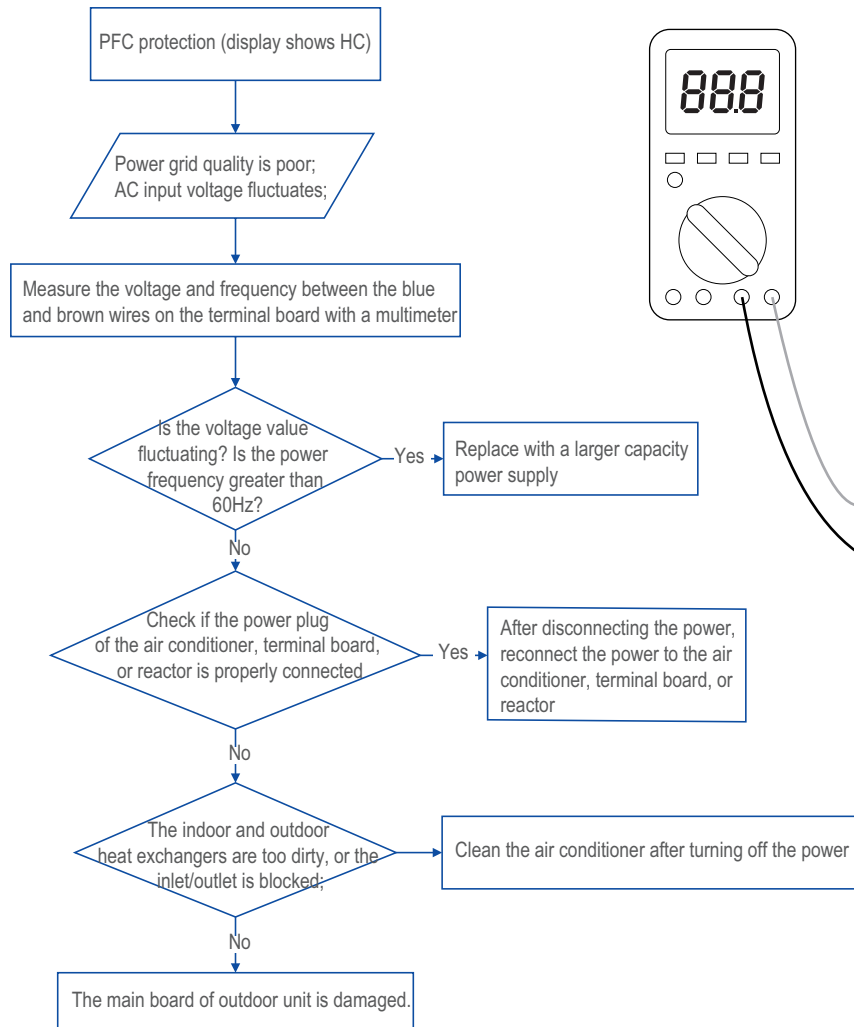

H7: Compressor Out of Step

1. Error description

When the compressor is running, the difference between the actual operating speed and the set speed is detected to exceed the set value (the set value is different for different models), and the H7 compressor out-of-step protection is reported.

2. Possible causes

- (1) The power supply voltage is abnormal;
- (2) The condenser or evaporator is dirty and blocked;
- (3) The air inlet and outlet of the indoor unit or outdoor unit are not smooth;
- (4) The system pipeline is blocked and the valve is not opened;
- (5) Too much refrigerant leads to excessive system pressure;
- (6) Poor wire contact;
- (7) The main board is damaged;
- (8) The compressor is damaged.

3. Troubleshooting

Troubleshoot according to the flow chart.

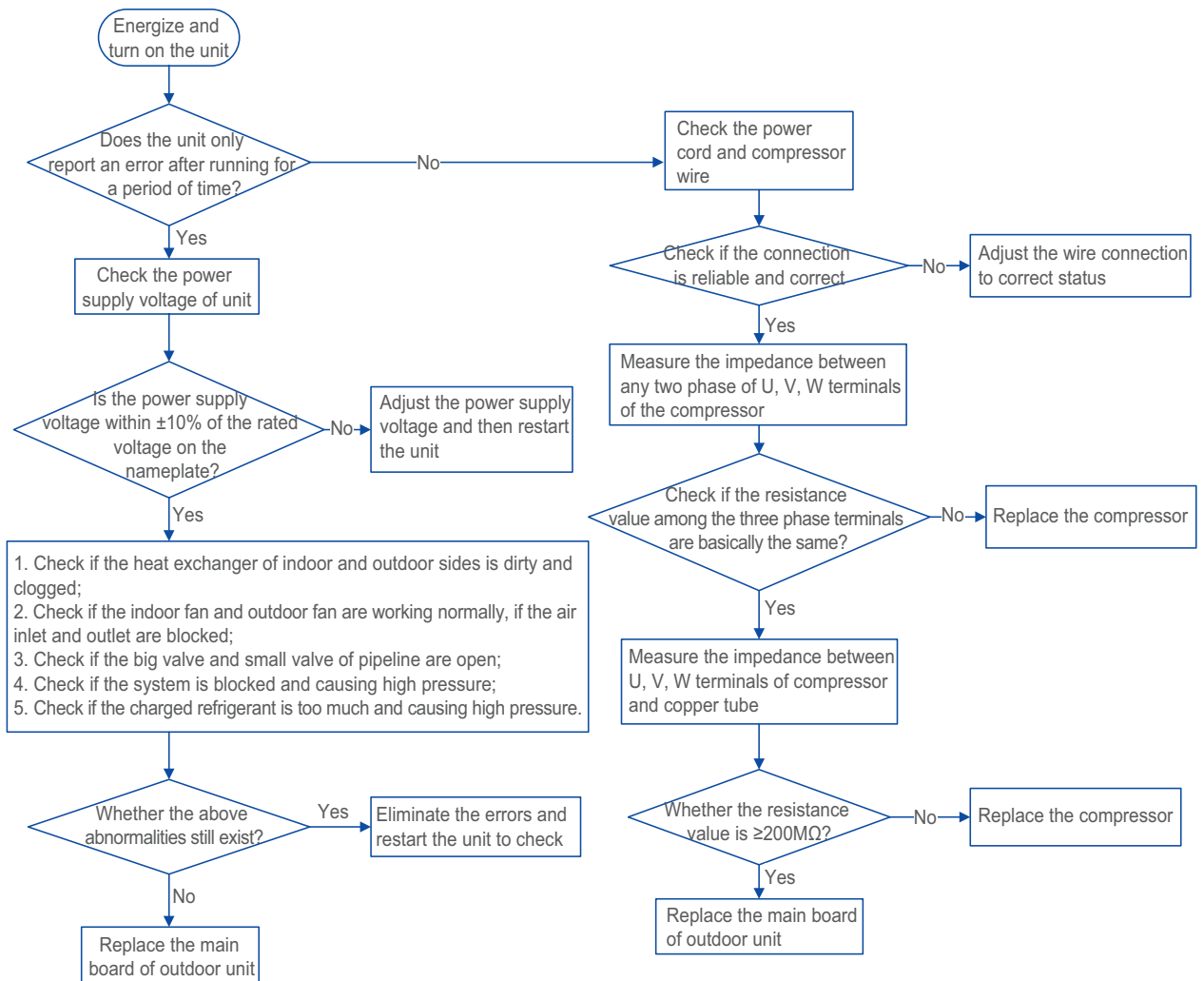

F0: Refrigerant Lack Protection, Refrigerant Circulation Stop Protection

1. Error description

This error code will be displayed when the main board of the indoor unit detects that the temperature difference between the inner tube and the inner ring is too small for a period of time.

2. Possible causes

- (1) The connecting pipe of the IDU and ODU is damaged or the connection is aging and loose, resulting in the leakage of refrigerant;
- (2) The liquid valve/air valve is aging and damaged, resulting in abnormal opening and closing control and pipeline blockage;
- (3) The temperature sensor is inaccurate and false alarm due to the damage and aging of the temperature sensor.

3. Troubleshooting

Check whether the temperature sensor and pipeline are damaged, and add refrigerant.

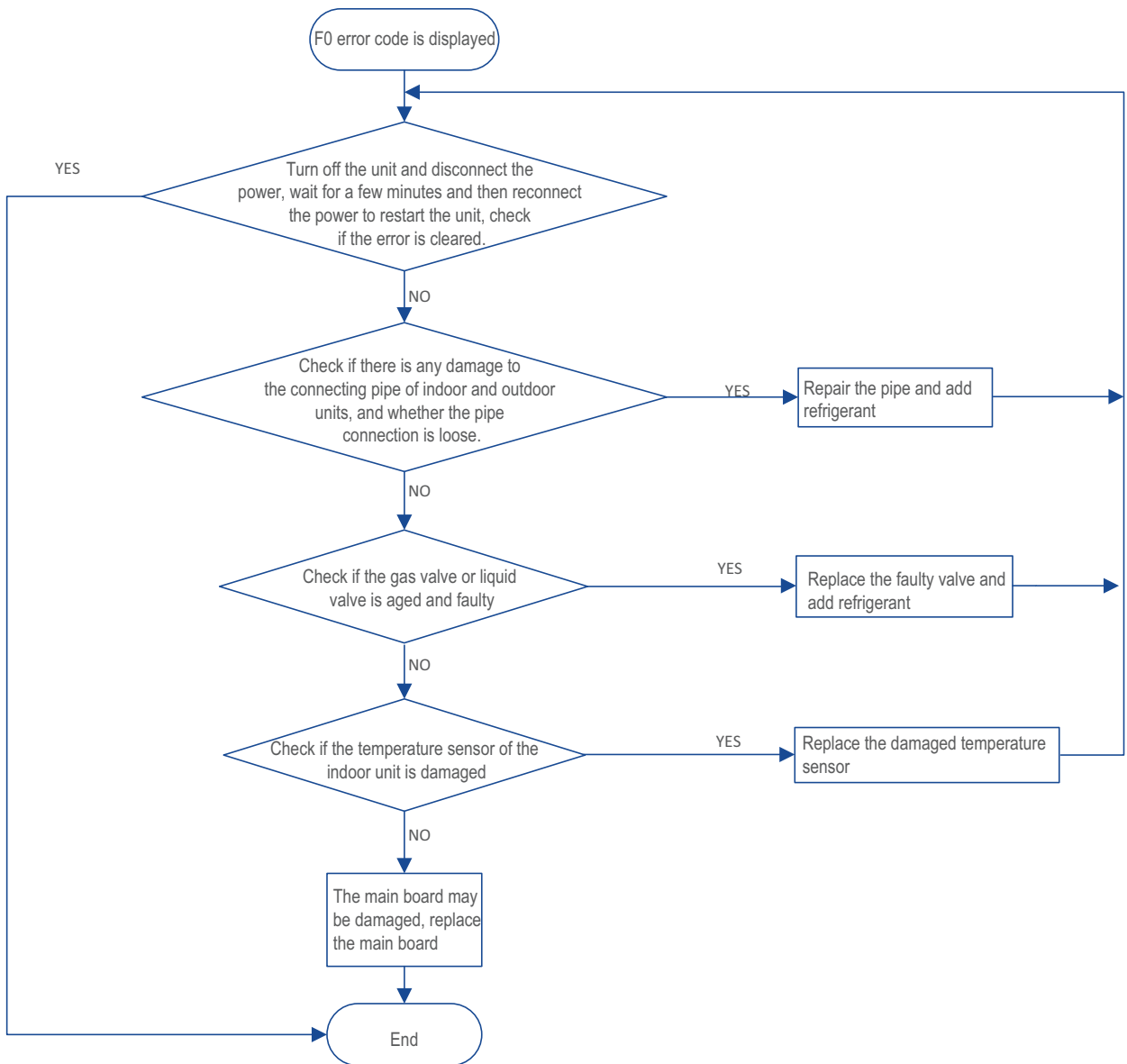

PH: High DC Bus Voltage

1. Error description

When the compressor is running, the DC bus voltage of the main board is detected, if the voltage value is higher than a certain value (such as 425-445V, the value is different due to different models), and it will report the high DC bus voltage protection.

2. Possible causes

- (1) The AC power supply voltage is too high, such as the AC power supply voltage is greater than 300V;
- (2) The power supply quality is poor, and the AC power supply voltage has abnormal fluctuation;
- (3) The main board is damaged.

3. Troubleshooting

Troubleshoot according to the flow chart.

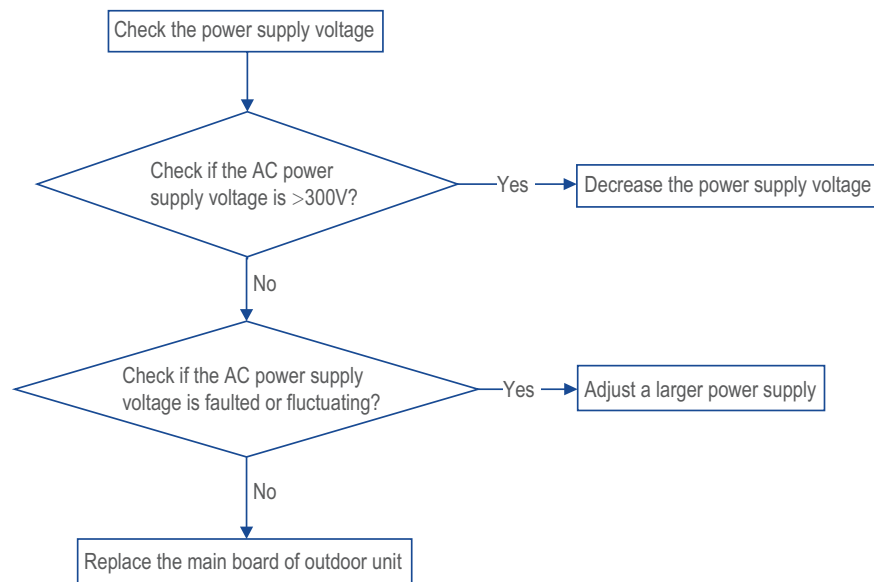

PL: Low DC Bus Voltage

1. Error description

When the compressor is running, the DC bus voltage is detected, if the voltage value is lower than a certain value (such as 120V~170V, different models), it will report low DC bus voltage protection.

2. Possible causes

- (1) The AC power supply voltage is too low, such as the AC power supply voltage is less than 90V;
- (2) The wiring of the unit is abnormal and the connecting wire is loose;
- (3) The main board of outdoor unit is damaged.

3. Troubleshooting

Troubleshoot according to the flow chart.

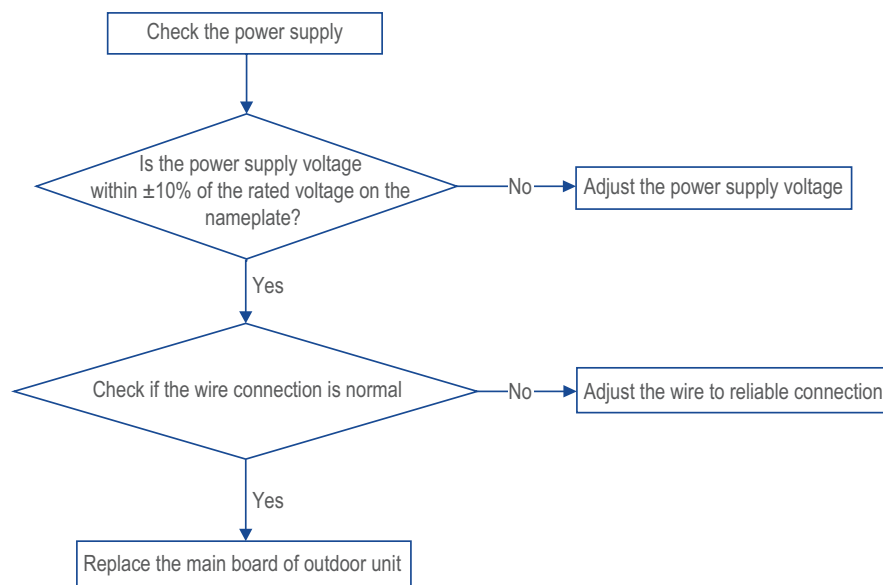

E8: High-Temperature Protection

1. Error description

If the main board detects that the temperature of the evaporator of indoor unit or the condenser of outdoor unit is too high, it will report an E8 high-temperature protection.

2. Possible causes

Cooling:

- (1) The condenser of the outdoor unit is dirty or clogged, leading to poor heat exchange;
- (2) Insufficient space or obstacles at the air inlet and outlet of the outdoor unit cause poor air circulation;
- (3) The fan blade of the outdoor unit is broken or falling off, or the motor is damaged;
- (4) The temperature sensor of condenser of the outdoor unit is damaged, or the main board is damaged, leading to inaccurate temperature sampling.

Heating:

- (1) The evaporator of the indoor unit is dirty or clogged, leading to poor heat exchange;
- (2) Insufficient space or obstacles at the air inlet and outlet of the indoor unit cause poor air circulation;
- (3) The fan blade of the indoor unit is broken or falling off;
- (4) The temperature sensor of evaporator of the indoor unit is damaged, or the main board is damaged, leading to inaccurate temperature sampling.

3. Troubleshooting

Troubleshoot according to the flow chart.

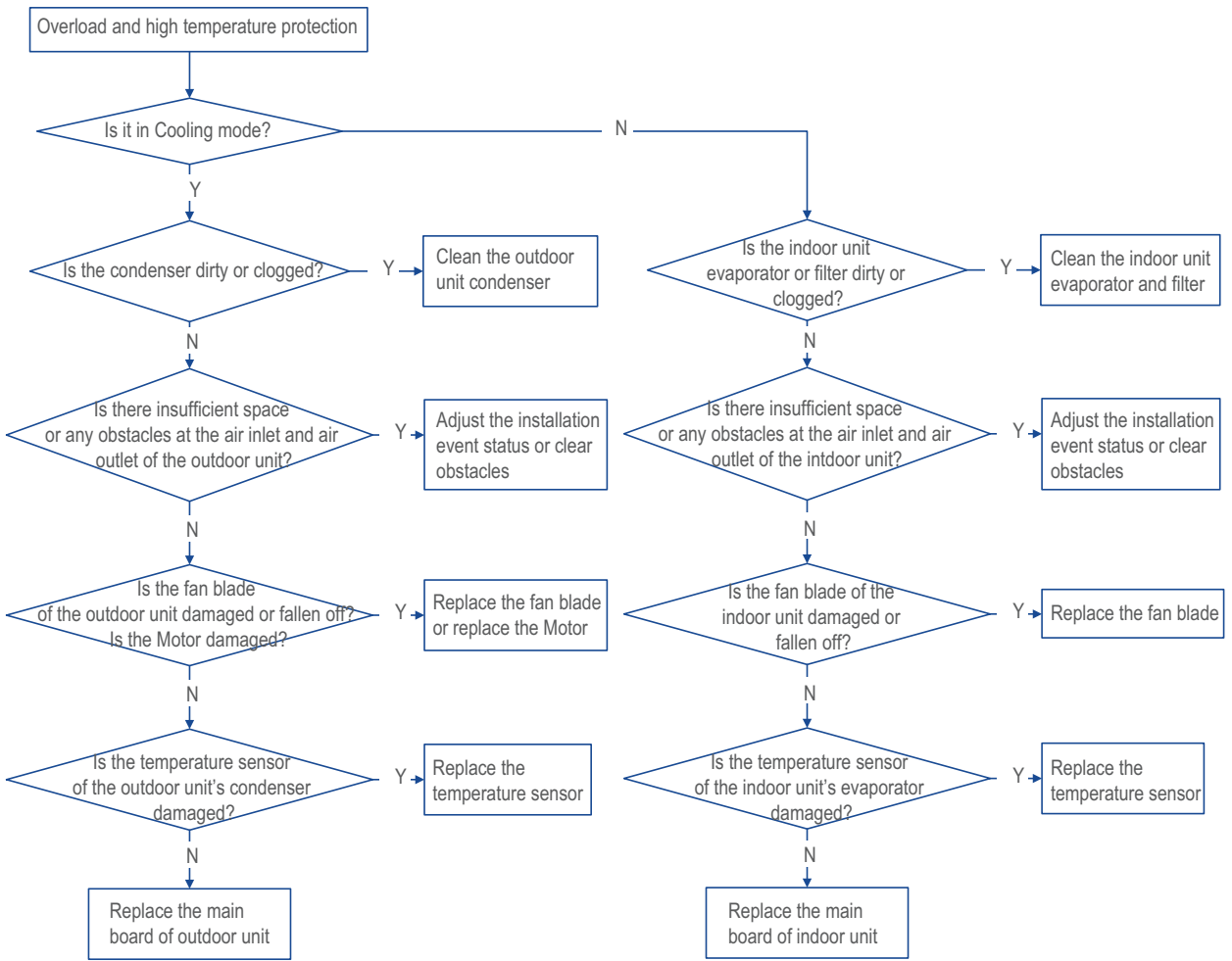

C5: Jumper Cap Error

1. Error description

If the jumper cap cannot be detected when the main board is powered on, the jumper cap error will be reported.

Principle: The jumper cap determines some of the operating parameters of the model, and if the jumper cap is not detected, the air conditioner cannot run.

2. Possible causes

- (1) The main board is not equipped with a jumper cap;
- (2) The jumper cap is not inserted properly.

3. Troubleshooting

- (1) Check whether the main board has installed the jumper cap;
- (2) Check whether the jumper cap of the main board is well inserted.

NOTE:

C4 refers to outdoor unit; C5 refers to indoor unit.

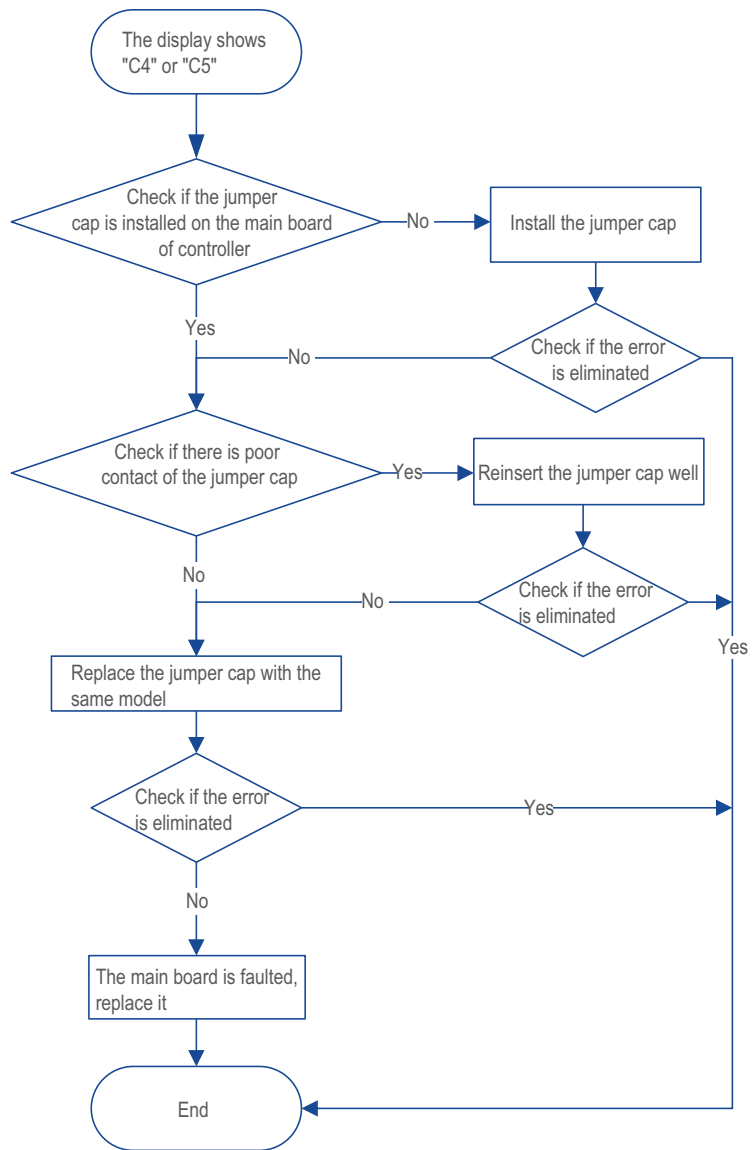

F 1, F2: Temperature Sensor Error

1. Error description

- (1) Cooling/dehumidification: All loads stop operation;
- (2) Heating: All loads stop running.

2. Possible causes

- (1) The temperature sensor is damaged;
- (2) The temperature sensor is not connected or has poor contact.

3. Troubleshooting

- (1) Check whether the connection between the temperature sensor and the main board is normal;
- (2) Check whether there is an open circuit or a short circuit at both ends of the temperature sensor;
- (3) If there is an abnormality in the circuit of the main board, replace the main board of the same model.

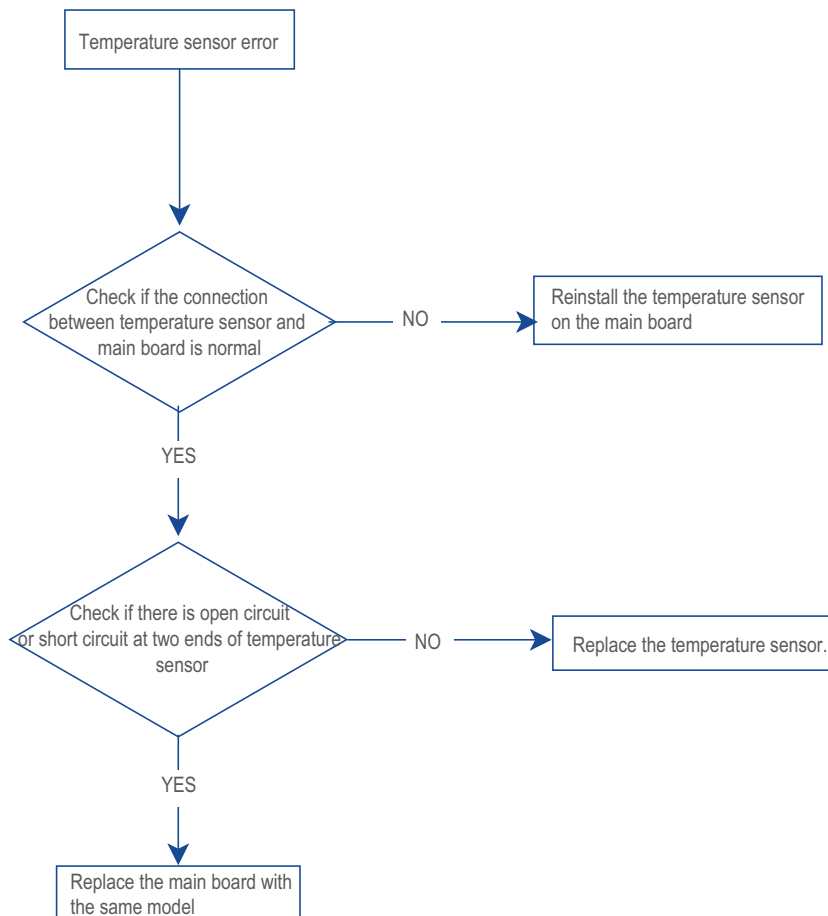

E5: Overcurrent Protection

1. Error description

During the operation of the air conditioner, the AC input current of the whole unit is detected, and when the detected current exceeds the set value (the set value is different for different models), the E5 overcurrent protection of the whole unit will be reported.

2. Possible causes

- (1) The power supply voltage is unstable;
- (2) The power supply voltage is too low;
- (3) The condenser or evaporator is dirty and clogged;
- (4) The air inlet and outlet of the indoor unit or outdoor unit are not smooth;
- (5) The system pipeline is blocked and the valve is not opened;
- (6) Too much refrigerant leads to excessive system pressure;
- (7) The main board is damaged;
- (8) The compressor is damaged.

3. Troubleshooting

Troubleshoot according to the flow chart.

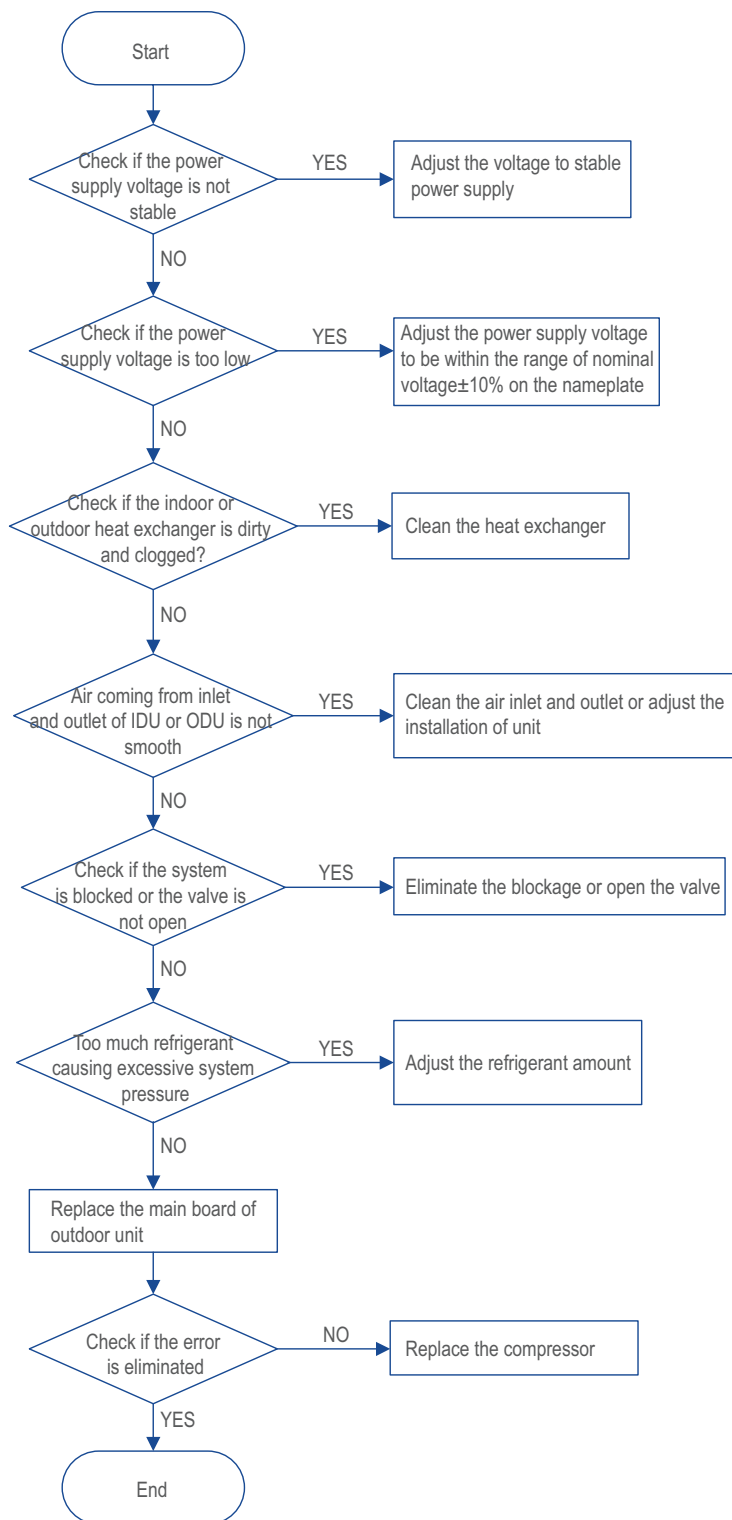

H3: Overload Protection of Compressor

1. Error description

When the main board detects that the compressor overload protection switch is disconnected, it will report the compressor overload protection.

Principle: The overload protection switch is in a short-circuit state at both ends under normal circumstances, and it will be disconnected when the temperature at the top of the compressor is too high.

2. Possible causes

- (1) The connection between the overload connection wire and the main board or the overload protector is unreliable, and the terminal is loose;
- (2) The overload protector is damaged, under normal circumstances, the impedance at both ends of the test overload protector should be less than 1Ω ;
- (3) The overload connection wire is damaged, resulting in the short circuit of wire;
- (4) Refrigerant leakage or system blockage;
- (5) The main board is damaged.

3. Troubleshooting

Troubleshoot according to the flow chart.

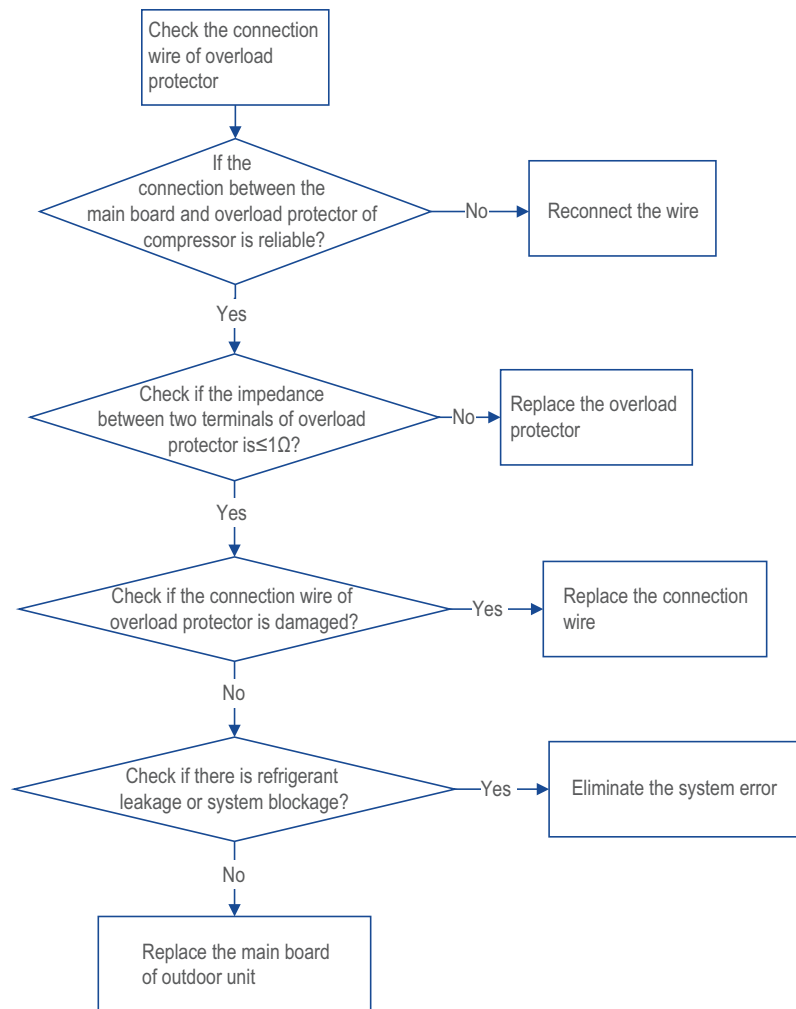

EA: Refrigerant Leak Alarm

1. Error description

If the refrigerant sensor detects that the refrigerant concentration exceeds 10%LFL, the refrigerant leak alarm will be triggered, and the indoor unit will display the EA code, the buzzer will beep, the fan will run, and the outdoor unit will stop.

If the refrigerant concentration is lower than 10%LFL for 5min30s, the refrigerant leak alarm will be withdrawn and the unit will resume normal operation.

2. Possible causes

- (1) Evaporator pipeline is damaged or the refrigerant leaks;
- (2) There is a possibility that flammable gases, explosive gases, smoke, ethanol gases (such as perfumes, etc.), and smoke-producing items (such as cigarettes, etc.) may trigger refrigerant leak alarms;
- (3) Electromagnetic interference, such as high-power electrical equipment may trigger sensor alarms.

3. Troubleshooting

- (1) Open the window for ventilation to reduce the indoor refrigerant concentration below the alarm threshold;
- (2) Detect whether there is refrigerant leakage in the unit, detect the pressure of the refrigerant in the unit, and see whether the amount of refrigerant is within the normal range;
- (3) Check the indoor air quality, if there is a gas that is easy to trigger the refrigerant leak alarm, please remove the gas;
- (4) Check the electromagnetic interference situation on the indoor side, if there is high-power equipment interfering with the refrigerant sensor, keep the high-power equipment far away from the air conditioner or turn off the high-power equipment;
- (5) Replace the refrigerant sensor.

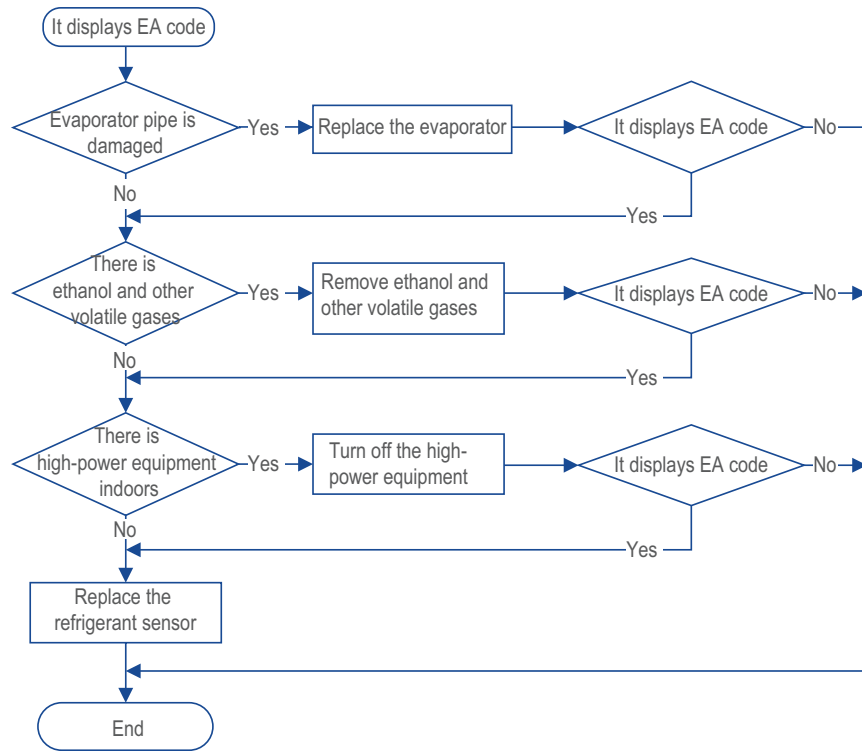

FE: Refrigerant Sensor Error

1. Error description

If there is internal error of the refrigerant sensor module or the communication between the refrigerant sensor and the main board is abnormal, the refrigerant sensor alarm will be triggered, and the indoor unit will display the FE code, buzzer will beep, the fan will operate, and the outdoor unit will stop (only applicable to some models).

2. Possible causes

- (1) The connection wire between refrigerant sensor and the main control is loose or in poor contact, and it can not communicate normally;
- (2) The service life of the refrigerant sensor has expired or failed, and it cannot communicate with the main control normally;
- (3) The communication circuit of the main control and refrigerant sensor is abnormal and it cannot communicate with the sensor normally.

3. Troubleshooting

- (1) Replace the connection wire between the refrigerant sensor and main control;
- (2) Replace the refrigerant sensor;
- (3) Replace the main board of the indoor unit.

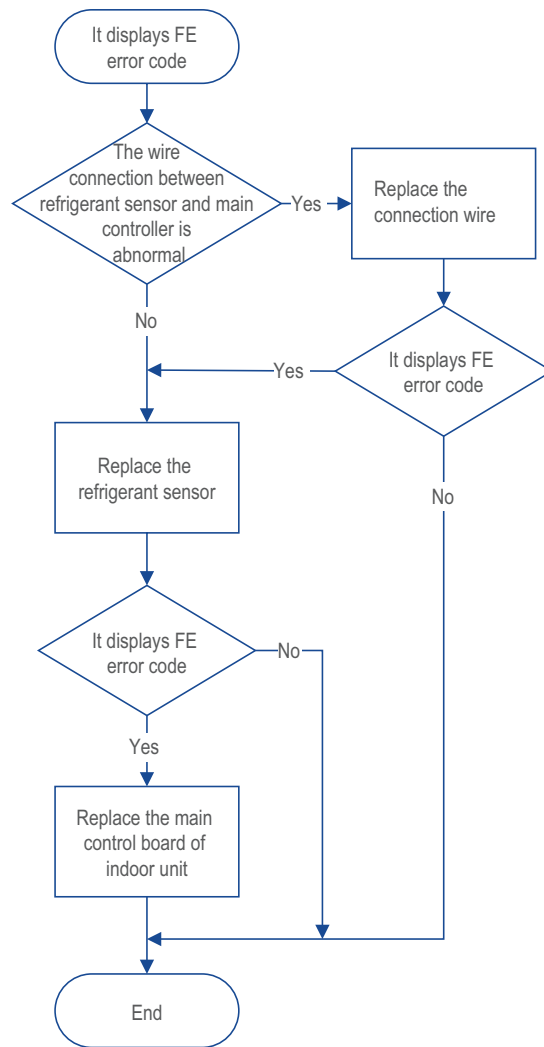

E 1: High Pressure Protection of System

1. Error description

When the main board detects that the system high pressure protection switch is disconnected, it will report system high pressure protection.

Principle: The system high pressure protection switch is in a short-circuit state at both ends under normal circumstances, and it will be disconnected when the system pressure exceeds the limit value.

2. Possible causes

- (1) The connection between the connecting wire and the main board or the high pressure protection switch is unreliable, or the terminal is loose;
- (2) The high pressure protection switch is damaged, under normal circumstances, the impedance of both ends of the high pressure protection switch should be less than 1Ω ;
- (3) The system pressure is too high due to abnormalities such as dirt blockage of the condenser or evaporator, unsmooth air inlet and outlet, excessive refrigerant, and blockage of system pipelines;
- (4) The main board is damaged.

3. Troubleshooting

Troubleshoot according to the flow chart.

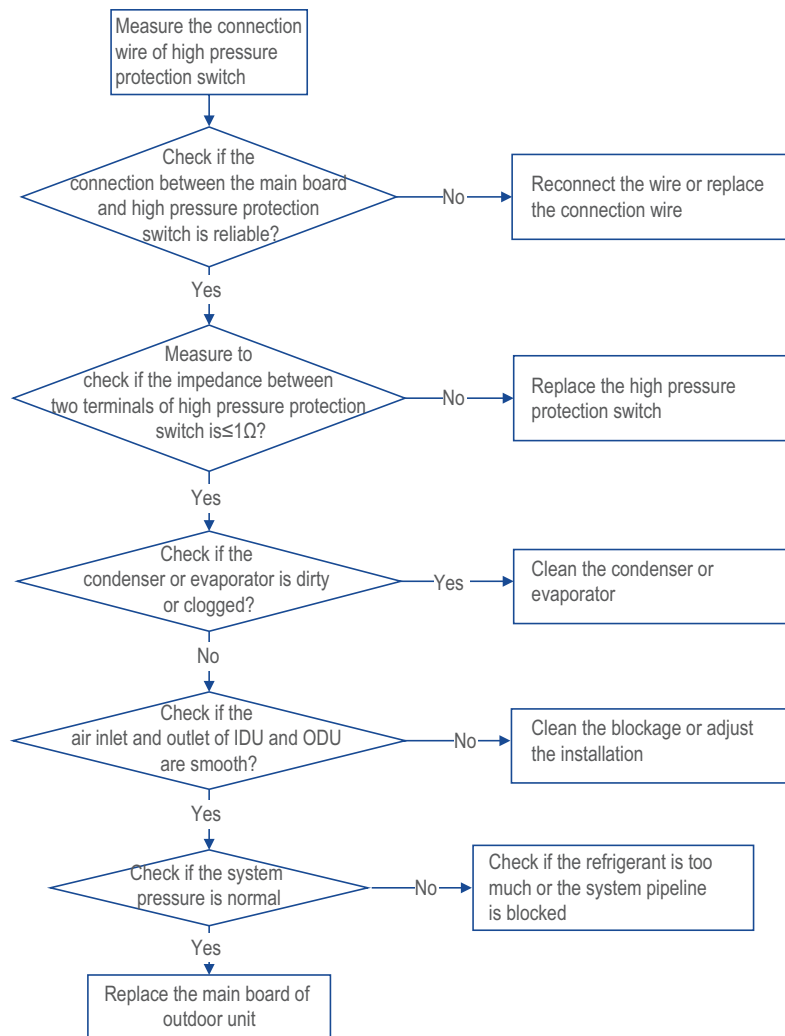

E3: Low Pressure Protection/System Low Pressure Protection/Compressor Low Pressure Protection

1. Error description

- (1) Cooling/dehumidification: Compressor and outdoor fan stop running;
- (2) Heating: All loads stop running;
- (3) Principle: The low pressure protection switch is normal closed. When the compressor pressure is too low, the switch will open. The mainboard detects the open signal and reports low-pressure protection.

2. Possible causes

- (1) Refrigerant leakage;
- (2) The low pressure protector is damaged or poorly connected;
- (3) The main board is damaged.

3. Troubleshooting

Check whether the connecting wire is damaged and whether it is reliably connected; check whether the low pressure protector is damaged; check whether there is a possibility of refrigerant leakage.

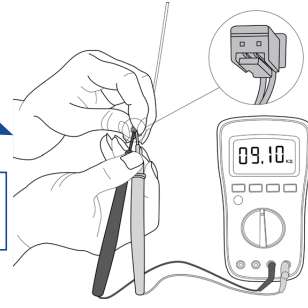
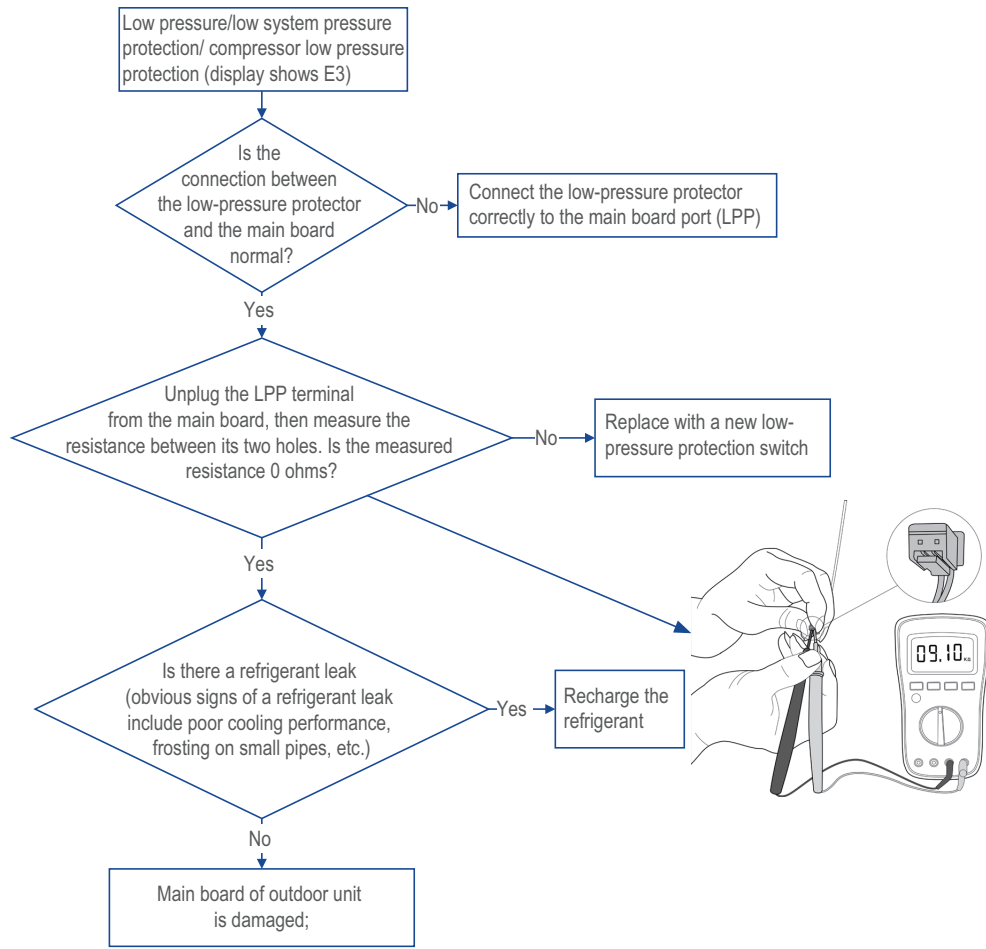

E7: Mode Conflict

1. Error description

If an outdoor unit is connected to multiple indoor units, and the operation modes of each indoor unit do not match, an E7 mode conflict error will be reported.

2. Possible causes

In multiple indoor units, some indoor units have the heating mode on, and some of the indoor units have the cooling mode, dry mode or air supply mode on, resulting in a conflict between the modes.

3. Troubleshooting

Troubleshoot according to the flow chart.

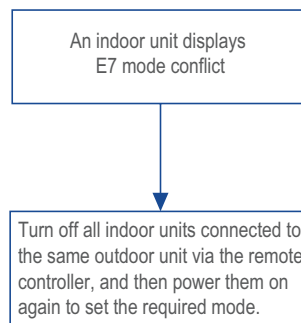

EE: Read EEPROM Error

1. Error description

- (1) Cooling/dehumidification: Compressor and outdoor fan stop running;
- (2) Heating: All loads stop running;
- (3) Principle: The memory chip or memory chip circuit fails, and it's unable to read the data from the memory chip.

2. Possible causes

- (1) The main board is damaged;
- (2) It is caused by misuse.

3. Troubleshooting

Disconnect the power supply and restart and wait for 5 ~ 8 minutes before turning on the unit to view, if it is still not recovered, replace the main board of the outdoor unit.

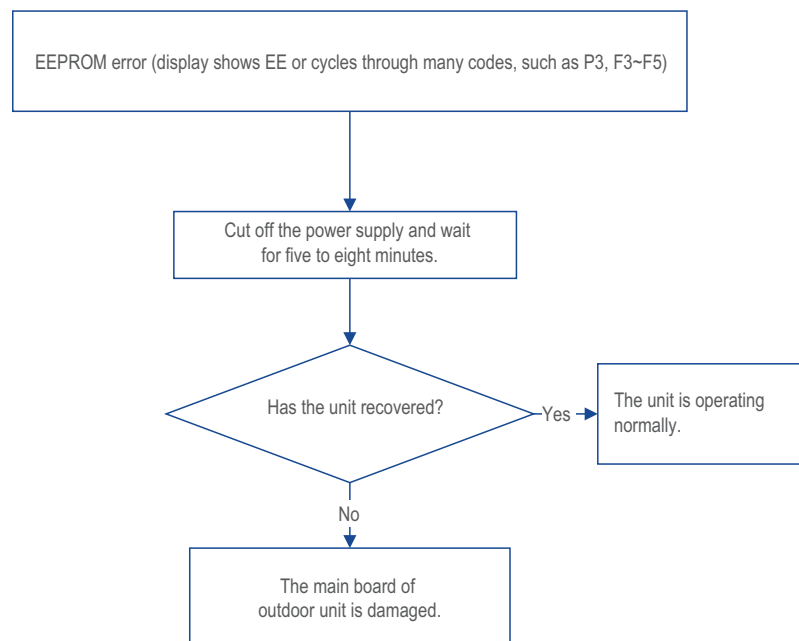

Lc: Startup Failure

1. Error description

If the compressor cannot be started successfully within a certain period of time, it will report the Lc compressor startup failure.

2. Possible causes

- (1) The power supply voltage is abnormal;
- (2) The system pipeline is blocked and the valve is not opened;
- (3) Too much refrigerant leads to excessive system pressure;
- (4) The main board is damaged;
- (5) The compressor is damaged.

3. Troubleshooting

Troubleshoot according to the flow chart.

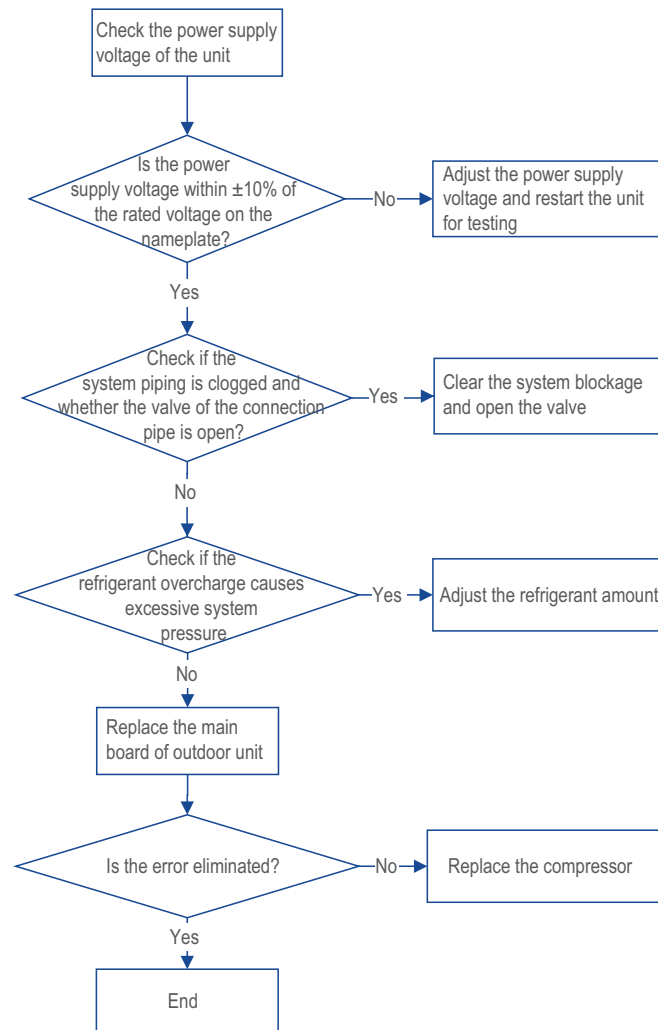

Ld: Phase-loss Protection of Compressor

1. Error description

During the operation of the air conditioner, the three-phase current of the compressor U, V and W is detected, and when a certain phase current loss is detected, the Ld compressor phase-loss protection will be reported.

2. Possible causes

- (1) The connection between the connecting wire and the main board or compressor is unreliable, and the terminal is loose;
- (2) The main board is damaged;
- (3) The compressor is damaged.

3. Troubleshooting

Troubleshoot according to the flow chart.

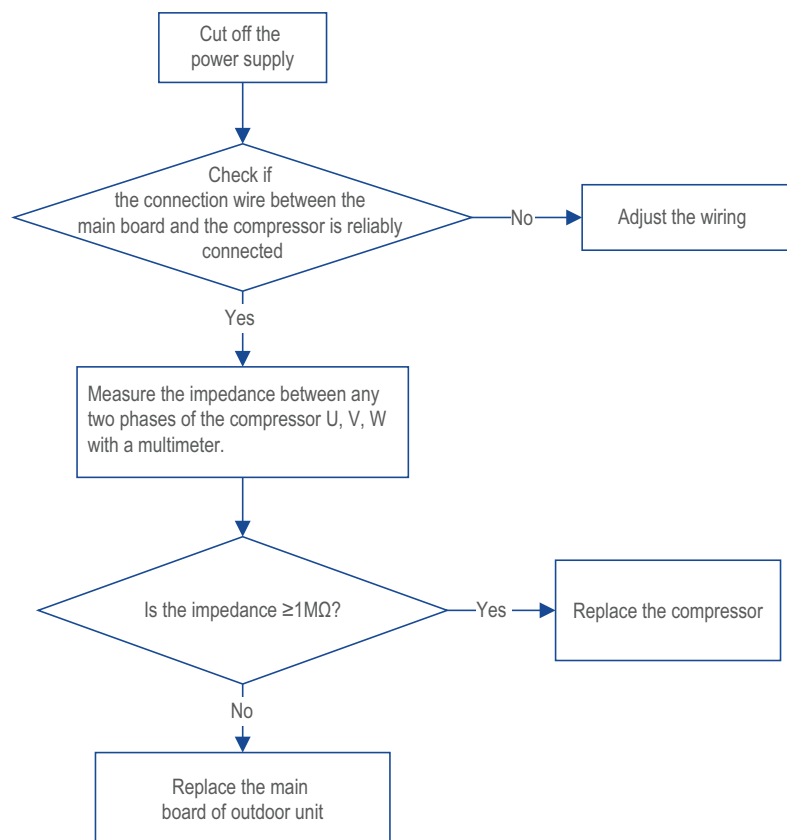

oE: Undefined Outdoor Unit Error

1. Error description

When the main board detects an error that causes the outdoor unit to shut down, this error code is displayed, usually accompanied by other error codes that cause the shutdown.

2. Possible causes

- (1) Compressor startup failure;
- (2) Compressor overload protection;
- (3) The indoor unit requires to shut down.

3. Troubleshooting

This error indicator is a general indicator, usually accompanied by other specific shutdown error codes, and needs to be analyzed and processed in combination with other shutdown error codes.

P7: Circuit Error of Module Temperature Sensor

1. Error description

- (1) Cooling/dehumidification: Compressor and outdoor fan stop running;
- (2) Heating: All loads stop running;
- (3) Principle: The main program detects that the temperature of the compressor IPM Module is abnormal, usually the compressor IPM Module or the detection circuit is damaged.

2. Possible causes

- (1) Compressor IPM Module is damaged;
- (2) The circuit of the main board of outdoor unit is damaged.

3. Troubleshooting

Disconnect the power supply and wait for 5 to 8 minutes before restarting the unit.

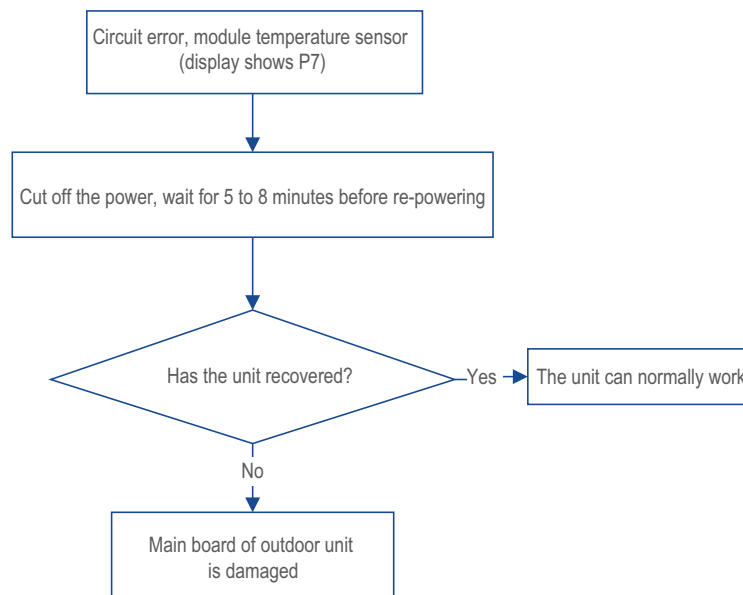

P8: High-temperature Protection of Module

1. Error description

- (1) Cooling/dehumidification: Compressor and outdoor fan stop running;
- (2) Heating: All loads stop running;
- (3) Principle: The main program detects that the module temperature is too high and exceeds the protection value.

2. Possible causes

- (1) The outdoor fan is blocked by foreign objects, resulting in poor heat dissipation;
- (2) The outdoor condenser is blocked by foreign objects, resulting in poor heat dissipation;
- (3) The screws between the IPM module and the radiator on the main board are not tightened, resulting in poor heat dissipation;
- (4) There is not enough thermal paste on the IPM;
- (5) The main board of outdoor unit is damaged.

3. Troubleshooting

- (1) Check whether the outdoor fan is blocked by foreign objects;
- (2) Check whether the outdoor condenser is blocked by foreign objects;
- (3) Check whether the screws between the IPM module and the radiator are tightened;
- (4) Check whether there is enough thermal paste on the IPM module.

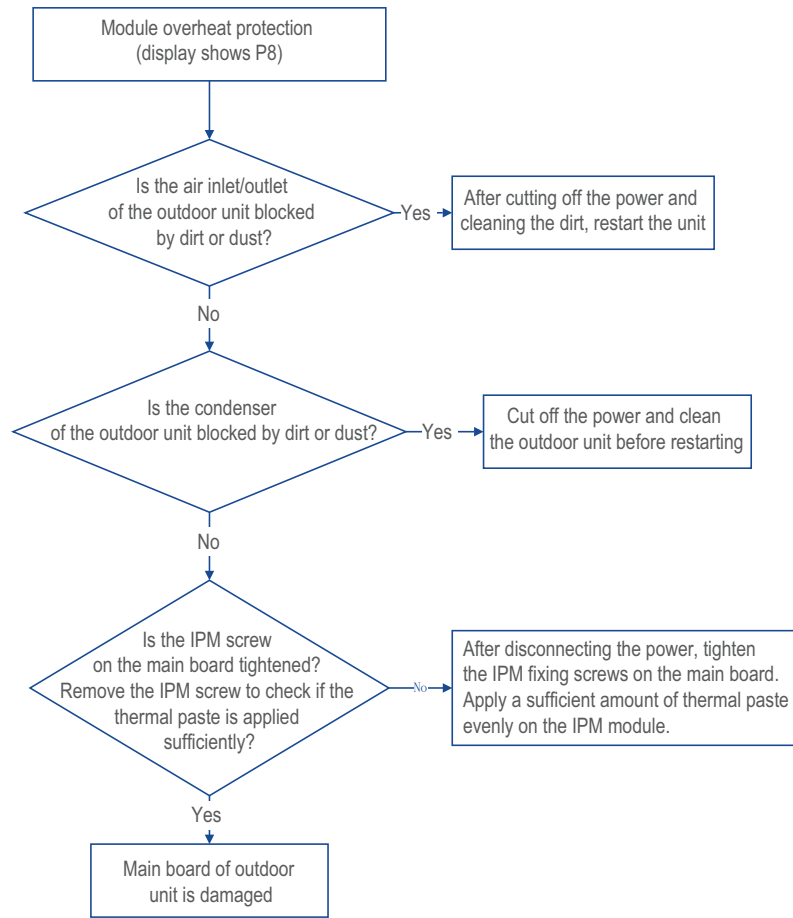

PU: Capacitor Charging Error

1. Error description

After energizing the unit, the voltage of the DC bus of the main board of outdoor unit has not reached 100V.

2. Possible causes

- (1) The AC power supply voltage is too low;
- (2) The reactor wiring is incorrect;
- (3) The main board of outdoor unit is damaged.

3. Troubleshooting

Troubleshoot according to the flow chart.

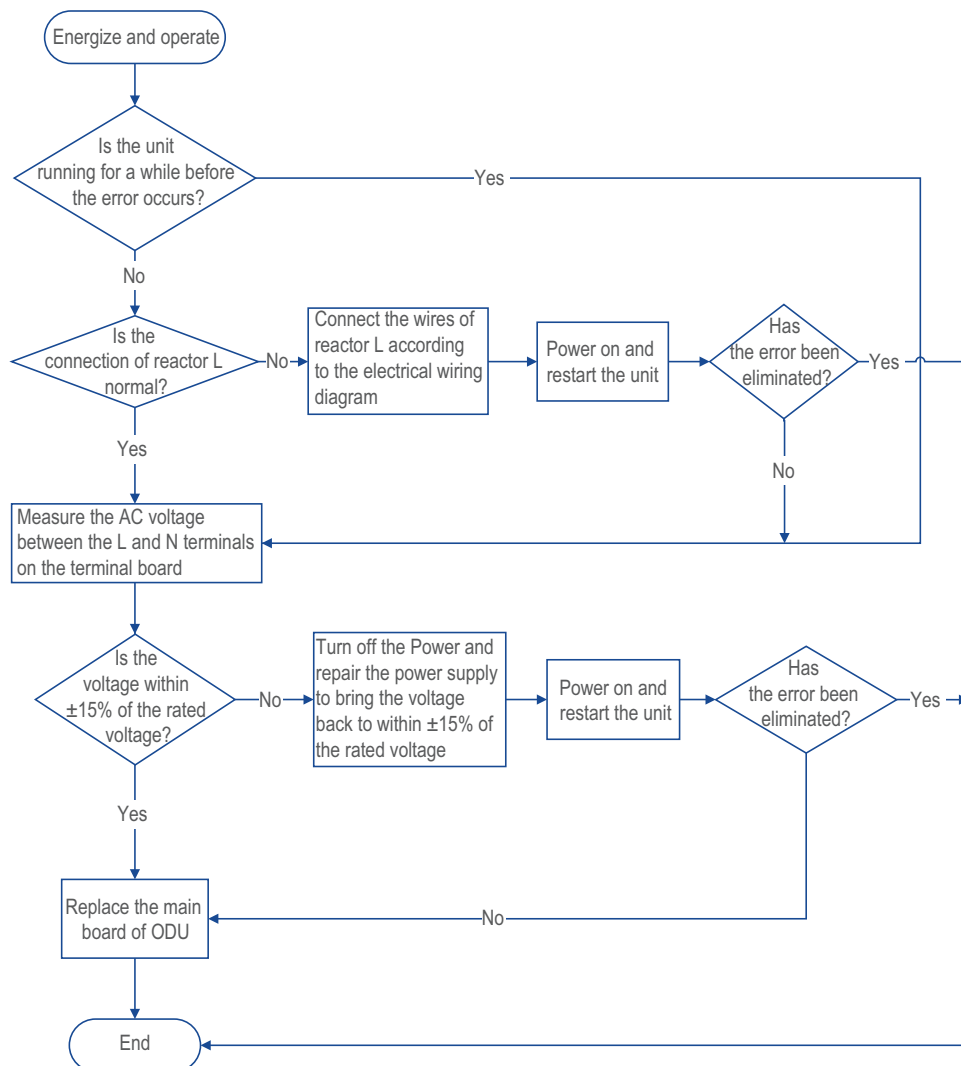

E9: Indoor Unit Water Full Protection

1. Error description

Main chip IO port reads the voltage level for the water level detection terminal. If the voltage level is high, the error code “E9” (water full) will be displayed.

2. Possible causes

- (1) Water level detection terminal is loose;
- (2) Liquid level switch error;
- (3) Drain pump error;
- (4) Drain pipe blockage;

3. Troubleshooting

Follow the flowchart.

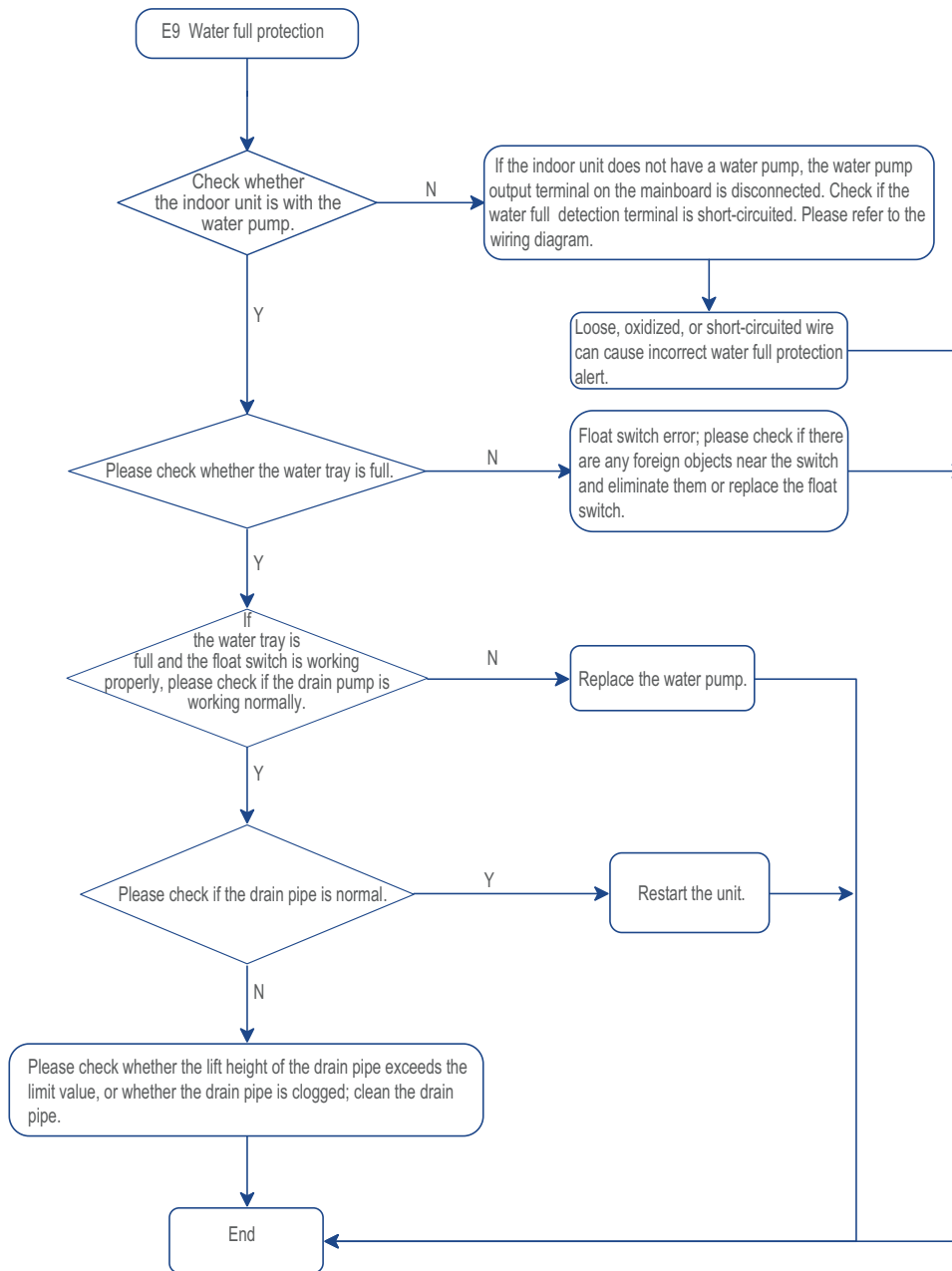

Networking Error

1. Error description

The APP cannot control the indoor unit normally/cannot connect to the network.

2. Possible causes

- (1) The APP version is not the latest;
- (2) The APP is not compatible with the mobile phone system;
- (3) The home network frequency band is not supported (not 2.4GHz);
- (4) The communication circuit between the main board and the WIFI module is abnormal.

3. Troubleshooting

- (1) Update the APP version;
- (2) Use other mobile phone brands or systems to connect to the network;
- (3) Check whether the home network meets the requirements;
- (4) Replace the main board or WIFI module.

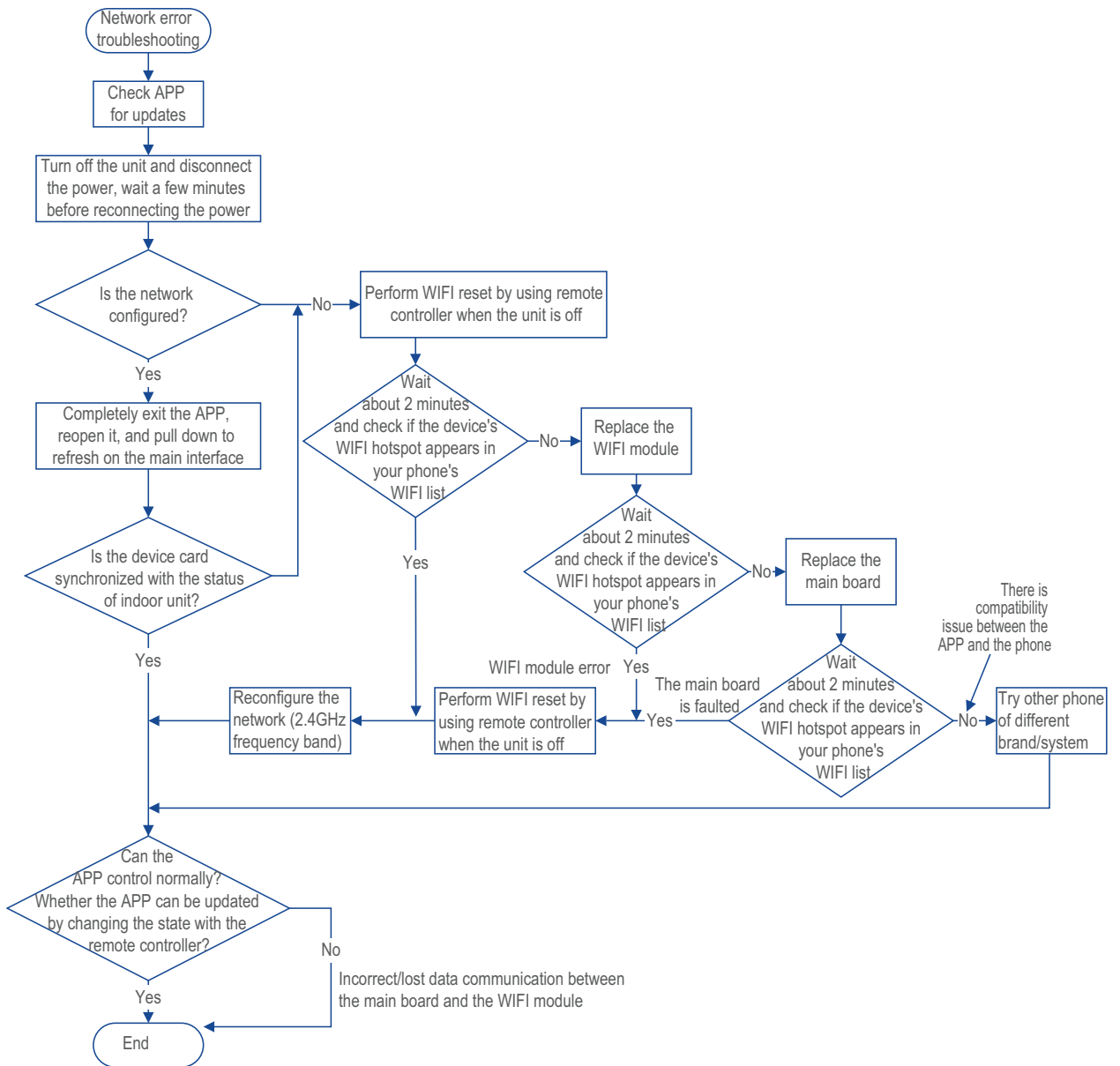

9.3 Checkup

1. Check the thermal resistor resistance

(1) Tool preparation

Multimeter.

(2) Find the model of thermal resistor

Check the label on the outer case of the thermal resistor to find the model number. Refer to the resistance table of thermal resistor in the appendix to find the resistance range corresponding to the model.

(3) Disconnection

Disconnect the thermal resistor from the connector on the PCB board. This ensures that you are measuring the resistance of the thermal resistor itself, not the entire circuit.

(4) Measure resistance

Use the resistance mode on the multimeter (usually marked as Ω). Place the two probes of the multimeter on the two pins of the thermal resistor to measure its resistance.

(5) Compare resistance

Compare the measured resistance with the resistance mode for the corresponding model in Appendix 4. If the measured resistance is outside the specified range, it indicates that the thermal resistor may be damaged and needs to be replaced.

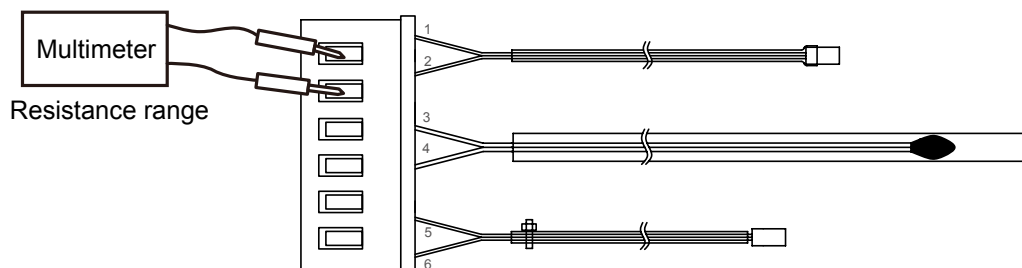
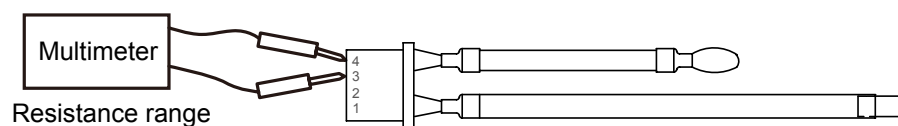

2. Check the electronic expansion valve

1. Check the connection

Check whether the connector of the electronic expansion valve (EV) is properly connected to the PCB board.

- Make sure that the connector is firmly plugged in and there is no looseness or poor contact.

2. Check the action sound

Turn off the power, then turn it back on, and check whether the electronic expansion valve makes a latching sound.

- This sound indicates that the electronic expansion valve is responding to the control signal.

3. Check the coil

If the electronic expansion valve does not make a latching sound in step 2, disconnect the connector and use a multimeter to check the conductivity of the connector.

- Use the resistance mode of the multimeter (usually marked as Ω), use the probe to touch the corresponding pins of the connector to check whether there is continuity. Check the conductivity between the connector pins. The specific pin combinations are as follows:

Pin 5 - 1

Pin 5 - 2

Pin 5 - 3

Pin 5 - 4

If there is no conduction between these pins (i.e. the measured resistance value is infinite), the coil of the electronic expansion valve may be damaged and the electronic expansion valve coil needs to be replaced.

4. Check the PCB board

If the conductivity between the pins is confirmed in step 3, but the electronic expansion valve still does not make a latching sound, it means that the PCB board of outdoor unit (main PCB board) may be faulty.

- Further inspection or replacement of the PCB board of outdoor unit is required.

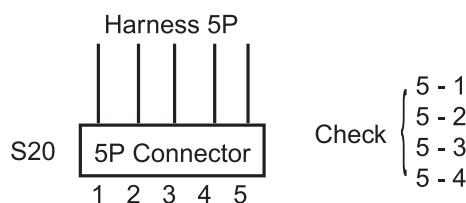

3. Check the compressor

1. Disconnect the power supply

Disconnect the compressor power cord from the PCB board of outdoor unit.

- Make sure the power supply is completely disconnected to avoid the risk of electric shock.

2. Measure the winding resistance

Use the resistance mode (usually marked as Ω) of the multimeter to measure the resistance between the compressor windings.

- The compressor usually has three terminals, namely U, V, W (or similar identification). The following combinations of resistance values need to be measured:

U - V

U- W

V- W

3. Check the resistance consistency

Make sure the resistance between any two terminals is roughly equal.

- Under normal circumstances, these three resistance values should be very close. If one resistance value is significantly different, it may indicate a problem with the winding.

4. Check the insulation to ground

Measure the resistance between each terminal and the outer case of compressor.

- Use one probe of the multimeter to touch the outer case of compressor and the other probe to the U, V, and W terminals respectively.
- If the measured resistance value is very low (close to 0Ω), there is a short circuit between the winding and the outer case and the compressor needs to be replaced.

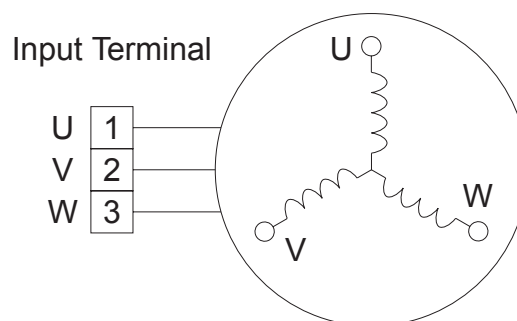

4. Check the 4-way valve coil

Measure the resistance between the two leads of the coil. If the resistance is between 500~2500Ω, the coil is normal. If the resistance is infinite, the coil is abnormal.

- The resistance of DC24V coil is about 550Ω;
- The resistance of AC110-120V coil is about 550Ω;
- The resistance of AC220-240V coil is about 2000~2500Ω.

9.4 Troubleshooting for Normal Malfunction

1. Air Conditioner Can't be Started Up

Possible Causes	Troubleshooting
No power supply, or poor connection for power plug	<ul style="list-style-type: none"> • Confirm whether it's due to power failure. — If yes, wait for power recovery. — If not, check power supply circuit and make sure the power plug is connected well.
Wrong wire connection between indoor unit and outdoor unit, or poor connection for wiring terminals	<ul style="list-style-type: none"> • Check the circuit according to circuit diagram and connect wires correctly. • Make sure all wiring terminals are connected firmly
Electric leakage for air conditioner	<ul style="list-style-type: none"> • Make sure the air conditioner is grounded reliably. • Make sure wires of air conditioner is connected correctly. • Check the wiring inside air conditioner. Check whether the insulation layer of power cord is damaged; if yes, place the power cord.
Model selection for air switch is improper	<ul style="list-style-type: none"> • Select proper air switch
Malfunction of remote controller	<ul style="list-style-type: none"> • Replace batteries for remote controller • Repair or replace remote controller

2. Poor Cooling (Heating) for Air Conditioner

Possible Causes	Troubleshooting
Set temperature is improper	<ul style="list-style-type: none"> ● Adjust the set temperature
Rotation speed of the IDU fan motor is set too low	<ul style="list-style-type: none"> ● Set the fan speed at high or medium
Filter of indoor unit is blocked	<ul style="list-style-type: none"> ● Clean the filter
Installation position for indoor unit and outdoor unit is improper	<ul style="list-style-type: none"> ● Adjust the installation position, and install the rainproof and sunproof for outdoor unit
Refrigerant is leaking	<ul style="list-style-type: none"> ● Find out the leakage causes and deal with it. Add refrigerant.
Malfunction of 4-way valve	<ul style="list-style-type: none"> ● Replace the 4-way valve
Malfunction of capillary	<ul style="list-style-type: none"> ● Replace the capillary
Flow volume of valve is insufficient	<ul style="list-style-type: none"> ● Open the valve completely
Malfunction of horizontal louver	<ul style="list-style-type: none"> ● Refer to point 3 of maintenance method for details
Malfunction of the IDU fan motor	<ul style="list-style-type: none"> ● Refer to troubleshooting for H6 for maintenance method in details
Malfunction of the ODU fan motor	<ul style="list-style-type: none"> ● Refer to point 4 of maintenance method for details
Malfunction of compressor	<ul style="list-style-type: none"> ● Refer to point 5 of maintenance method for details

3. *Horizontal Louver Can't Swing*

Possible Causes	Troubleshooting
Wrong wire connection, or poor connection	<ul style="list-style-type: none">• Connect wires according to wiring diagram to make sure all wiring terminals are connected firmly
Stepping motor is damaged	<ul style="list-style-type: none">• Repair or replace stepping motor
Main board is damaged	<ul style="list-style-type: none">• Replace the main board with the same model

4. *ODU Fan Motor Can't Operate*

Possible Causes	Troubleshooting
Wrong wire connection, or poor connection	<ul style="list-style-type: none">• Connect wires according to wiring diagram to make sure all wiring terminals are connected firmly
Capacity of the ODU fan motor is damaged	<ul style="list-style-type: none">• Replace the capacity of fan
Power voltage is a little low or high	<ul style="list-style-type: none">• Suggest to equip with voltage regulator
Motor of outdoor unit is damaged	<ul style="list-style-type: none">• Change compressor oil and refrigerant. If no better, replace the compressor with a new one

5. *Air Conditioner is Leaking*

Possible Causes	Troubleshooting
Drain pipe is blocked	<ul style="list-style-type: none">• Eliminate the foreign objects inside the drain pipe
Drain pipe is broken	<ul style="list-style-type: none">• Replace drain pipe
Wrapping is not tight	<ul style="list-style-type: none">• Wrap it again and bundle it tightly

6. *Compressor Can't Operate*

Possible Causes	Troubleshooting
Wrong wire connection, or poor connection	<ul style="list-style-type: none">• Connect wires according to wiring diagram to make sure all wiring terminals are connected firmly
Capacity of compressor is damaged	<ul style="list-style-type: none">• Replace the compressor capacitor
Power voltage is a little low or high	<ul style="list-style-type: none">• Suggest to equip with voltage regulator
Coil of compressor is burnt out	<ul style="list-style-type: none">• Repair or replace compressor
Cylinder of compressor is blocked	<ul style="list-style-type: none">• Repair or replace compressor

7. Abnormal Sound and Vibration

Possible Causes	Troubleshooting
When turn on or turn off the unit, the panel and other parts will expand and there's abnormal sound	<ul style="list-style-type: none"> • Normal phenomenon. Abnormal sound will disappear after a few minutes.
When turn on or turn off the unit, there's abnormal sound due to flow of refrigerant inside air conditioner	<ul style="list-style-type: none"> • Normal phenomenon. Abnormal sound will disappear after a few minutes.
Foreign objects inside the indoor unit or there are parts touching together inside the indoor unit	<ul style="list-style-type: none"> • Remove foreign objects. Adjust all parts position of indoor unit, tighten screws and stick damping plaster between connected parts
Foreign objects inside the outdoor unit or there are parts touching together inside the outdoor unit	<ul style="list-style-type: none"> • Remove foreign objects. Adjust all parts position of outdoor unit, tighten screws and stick damping plaster between connected parts
Short circuit inside the magnetic coil	<ul style="list-style-type: none"> • Replace magnetic coil
Abnormal shake of compressor	<ul style="list-style-type: none"> • Adjust the support foot mat of compressor, tighten the bolts
Abnormal sound inside the compressor	<ul style="list-style-type: none"> • If add too much refrigerant during maintenance, please reduce refrigerant properly. Replace compressor for other circumstances.

10. Removal Procedure

Caution: discharge the refrigerant completely before removal.

GKH(09)EB-D6DNA5A/I GKH(12)EB-D6DNA5A/I GKH(18)EB-D6DNA5A/I GKH(24)EC-D6DNA6A/I

Removal of fan and motor

Note: Before removing the motor, power must be cut off.

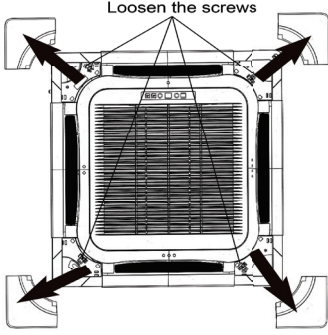
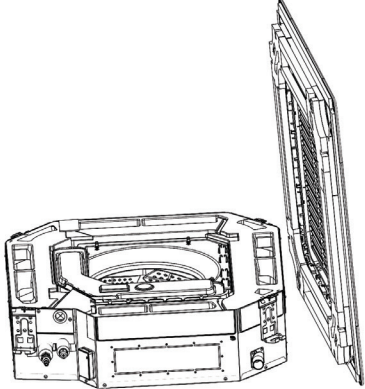
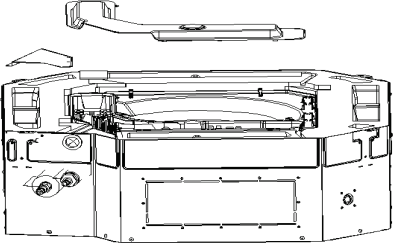
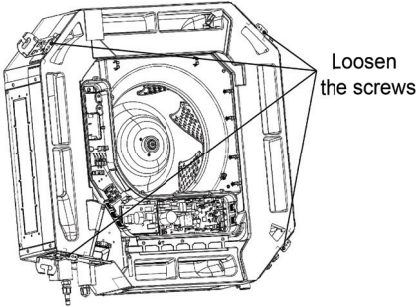
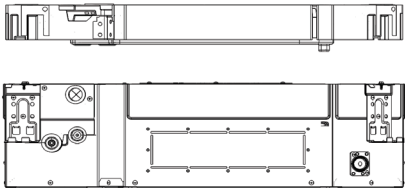
Step	Picture	Work instruction
1. Remove the front panel.	 	<ul style="list-style-type: none"> ● Turn off the power supply of indoor unit. ● Push the 4 corner plates in the directions shown by the arrows. ● Loosen the screws and remove the front panel.
2. Remove the cover of electric box and the clamp of power cord.		<ul style="list-style-type: none"> ● Remove the motor wire and water pump of the electric box.
3. Remove the water tray.	 	<ul style="list-style-type: none"> ● Loosen the screws in the 4 corners and then remove the water tray.

Removal of fan and motor

Note: Before removing the motor, power must be cut off.

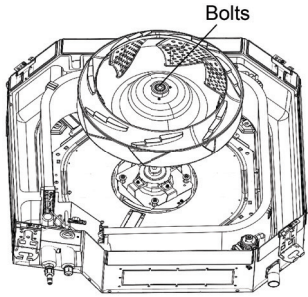
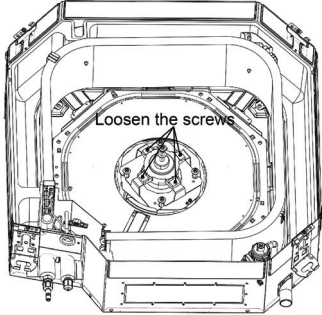
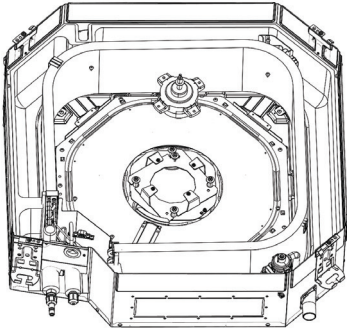
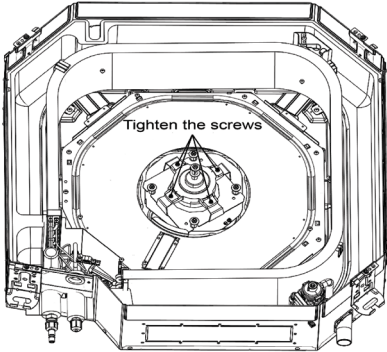
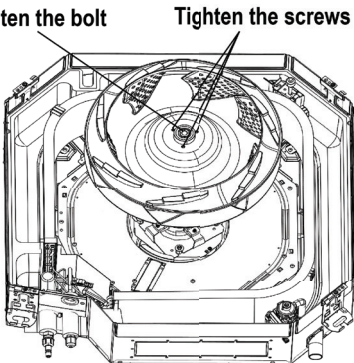
Step	Picture	Work instruction
4. Remove the fan.		<ul style="list-style-type: none"> ● Use a screwdriver to remove the clamping band of motor. Then remove the fan.
5. Remove motor.		<ul style="list-style-type: none"> ● Use a screwdriver to unscrew the 4 screws of motor. Then remove the motor.
		
6. Replace and install the motor.		<ul style="list-style-type: none"> ● Remove the motor from motor support and then replace with a new motor. ● Tighten the 4 screws of motor with a screwdriver.
7. Install the fan.		<ul style="list-style-type: none"> ● Direct the hole of fan to the motor shaft and then mount on the fan. ● Tighten the clamping band of motor with a wrench.

Removal of fan and motor

Note: Before removing the motor, power must be cut off.

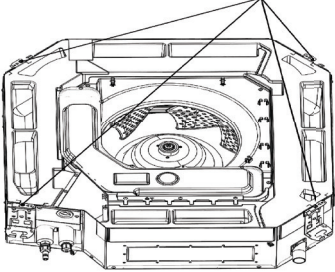
Step	Picture	Work instruction
8. Install the water tray.	<p>Tighten the screws</p> 	<ul style="list-style-type: none"> ● Direct the 4 corners of water tray to the 4 corners of the unit and then press them. Use a screwdriver to tighten the screws in the 4 corners. ● Connect the power cord and water pump wire. ● Place back the cover of electric box and the clamp of power cord. Then tighten the screws with a screwdriver.

Removal and installation of drain pump

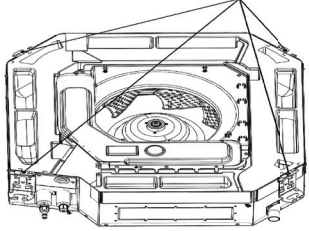
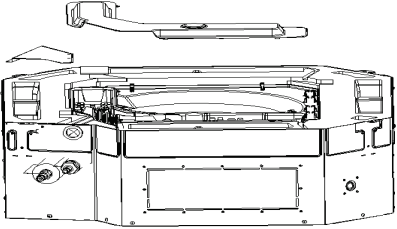
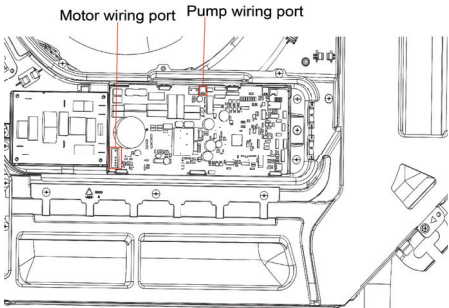
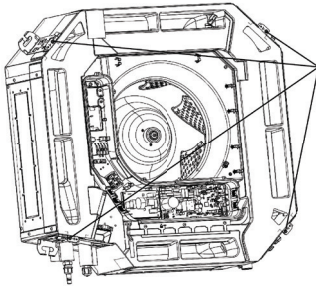
Step	Picture	Work instruction
1. After removing the front panel as instructed above, loosen the screws of the water tray.	<p>Loosen the screws</p> 	<ul style="list-style-type: none"> ● Use a screwdriver to loosen the screws of water tray.
2. Remove the cover of electric box and the clamp of power cord.		<ul style="list-style-type: none"> ● Twist off the screws and open the cover of electric box and the clamp of power cord.
3. Remove the motor wire and water pump wire.	<p>Motor wiring port Pump wiring port</p> 	<ul style="list-style-type: none"> ● Remove the motor wire and water pump wire in the electric box.
4. Remove the water tray.	<p>Loosen the screws</p> 	<ul style="list-style-type: none"> ● Loosen the screws in the 4 corners and then remove the water tray.

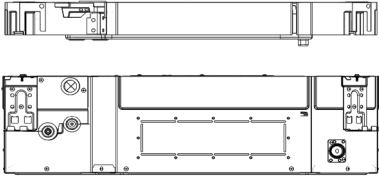
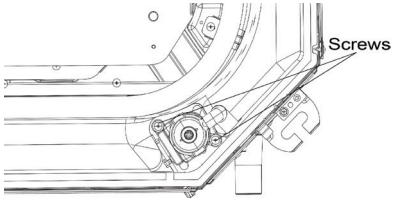
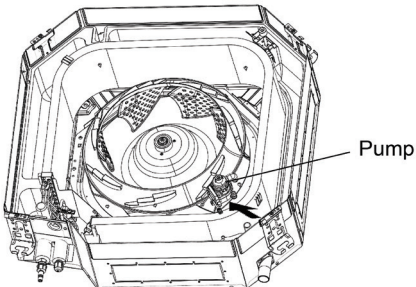
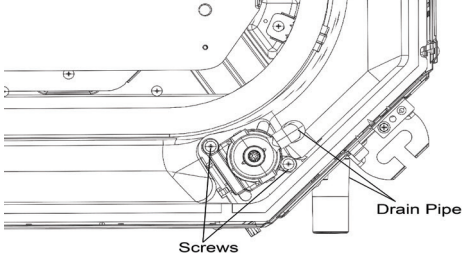
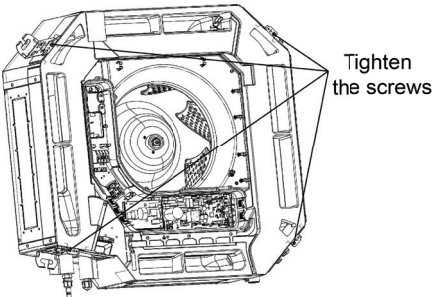
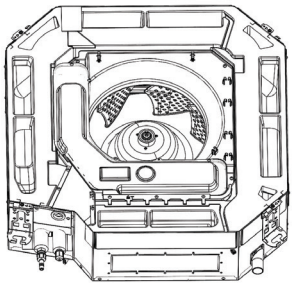

Removal and installation of drain pump

Step	Picture	Work instruction
		
<p>5. Remove the drain pipe and loosen the screws of water pump.</p>		<ul style="list-style-type: none"> ● Take out the drain pipe and use a screwdriver to loosen the screws of water pump.
<p>6. Remove and replace the pump.</p>		<ul style="list-style-type: none"> ● Remove the pump and replace with a new one.
<p>7. Connect the drain pipe and tighten the screws of water pump.</p>		<ul style="list-style-type: none"> ● Connect the drain pipe and tighten the screws of water pump.
<p>8. Install the water tray and tighten the screws.</p>		<ul style="list-style-type: none"> ● Direct the 4 corners of the water tray to the 4 corners of the unit and press them. Then use a screwdriver to tighten the screws.
<p>9. Connect the water pump wire and power cord, and then put back the cover of electric box and the clamp of power cord.</p>		<ul style="list-style-type: none"> ● Connect the water pump wire and motor wire according to the wiring diagram. ● Put back the cover of electric box and the clamp of power cord. Then tighten the screws.

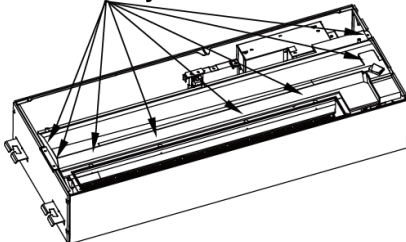
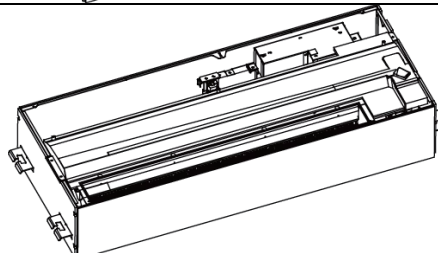
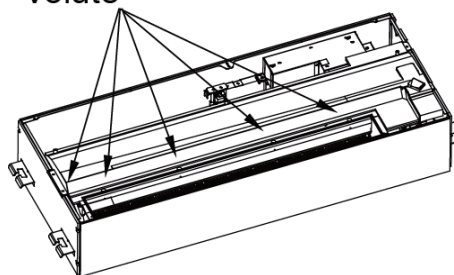
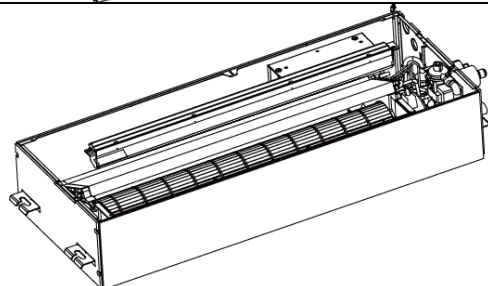
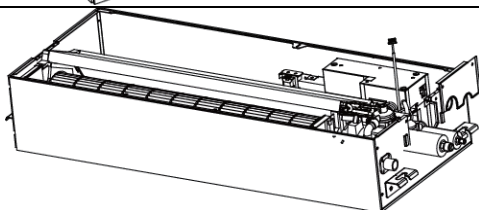
⚠ Warning: Be sure to wait for a minimum of 20 minutes after turning off all power supplies and discharge the refrigerant completely before removal.

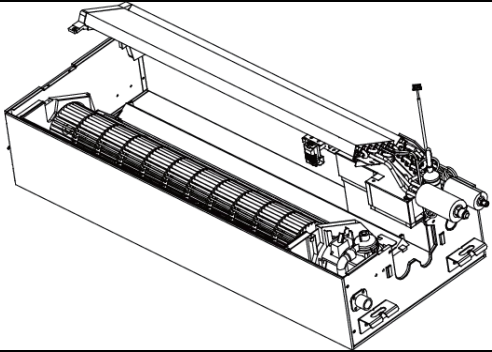
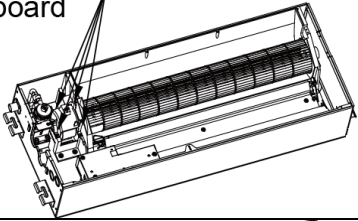
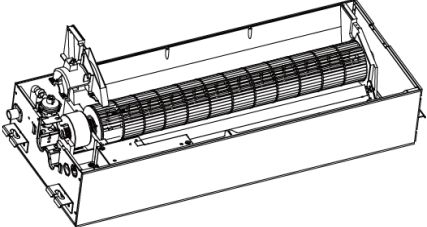
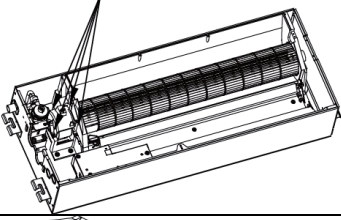
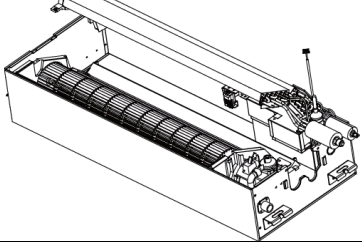
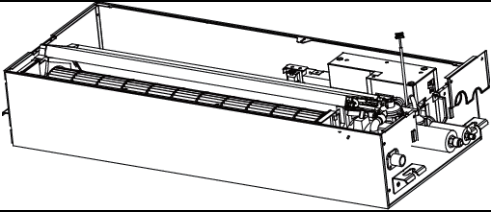
Motor and fan		
Step	Diagram	Operation Procedure
1. Unscrew the water tray.	<p>Unscrew the water tray</p> 	<ul style="list-style-type: none"> ● Use a screwdriver to unscrew the water tray.
2. Remove the water tray.		<ul style="list-style-type: none"> ● Remove the water tray.
3. Unscrew the volute tongue.	<p>Unscrew the volute</p> 	<ul style="list-style-type: none"> ● Use a screwdriver to unscrew the volute tongue.
4. Remove the volute tongue.		<ul style="list-style-type: none"> ● Remove the volute tongue.
5. Unscrew the outlet board.		<ul style="list-style-type: none"> ● Use a screwdriver to unscrew the outlet board and then remove the board.

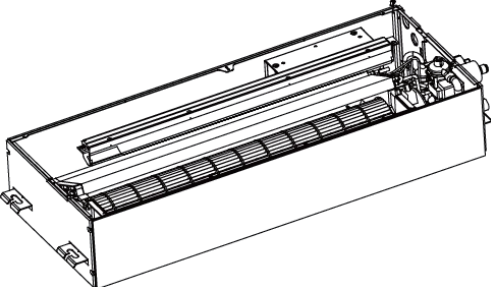
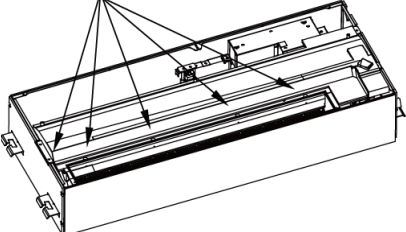
Motor and fan		
Step	Diagram	Operation Procedure
6. Remove the evaporator.		<ul style="list-style-type: none"> ● Remove the evaporator.
7. Unscrew the motor pressing board.	<p>Unscrew the motor pressing board</p> 	<ul style="list-style-type: none"> ● Use a screwdriver to unscrew the motor pressing board.
8. Remove the pressing board and replace the motor.		<ul style="list-style-type: none"> ● Remove the pressing board and replace the motor.
9. Screw the motor pressing board.	<p>Screw the motor pressing board</p> 	<ul style="list-style-type: none"> ● Use a screwdriver to screw the motor pressing board.
10. Install the evaporator.		<ul style="list-style-type: none"> ● Install the evaporator.
11. Screw the outlet board.		<ul style="list-style-type: none"> ● Use a screwdriver to screw the outlet board.

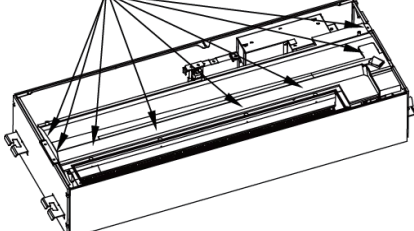
Motor and fan		
Step	Diagram	Operation Procedure
12. Put the volute tongue back to position.		<ul style="list-style-type: none"> ●Put the volute tongue back to position.
13. Screw the volute tongue.	<p>Screw the volute</p> 	<ul style="list-style-type: none"> ●Use a screwdriver to screw the volute tongue.
14. Install the water tray.		<ul style="list-style-type: none"> ●Install the water tray.
15. Screw the water tray.	<p>Screw the water tray</p> 	<ul style="list-style-type: none"> ●Use a screwdriver to screw the water tray.

Appendix

Appendix 1: Reference Sheet of Celsius and Fahrenheit

Conversion formula for Fahrenheit degree and Celsius degree: $T_f = T_c \times 1.8 + 32$

Set temperature

Fahrenheit display temperature (°F)	Fahrenheit (°F)	Celsius (°C)	Fahrenheit display temperature (°F)	Fahrenheit (°F)	Celsius (°C)	Fahrenheit display temperature (°F)	Fahrenheit (°F)	Celsius (°C)
61	60.8	16	69/70	69.8	21	78/79	78.8	26
62/63	62.6	17	71/72	71.6	22	80/81	80.6	27
64/65	64.4	18	73/74	73.4	23	82/83	82.4	28
66/67	66.2	19	75/76	75.2	24	84/85	84.2	29
68	68	20	77	77	25	86	86	30

Ambient temperature

Fahrenheit display temperature (°F)	Fahrenheit (°F)	Celsius (°C)	Fahrenheit display temperature (°F)	Fahrenheit (°F)	Celsius (°C)	Fahrenheit display temperature (°F)	Fahrenheit (°F)	Celsius (°C)
32/33	32	0	55/56	55.4	13	79/80	78.8	26
34/35	33.8	1	57/58	57.2	14	81	80.6	27
36	35.6	2	59/60	59	15	82/83	82.4	28
37/38	37.4	3	61/62	60.8	16	84/85	84.2	29
39/40	39.2	4	63	62.6	17	86/87	86	30
41/42	41	5	64/65	64.4	18	88/89	87.8	31
43/44	42.8	6	66/67	66.2	19	90	89.6	32
45	44.6	7	68/69	68	20	91/92	91.4	33
46/47	46.4	8	70/71	69.8	21	93/94	93.2	34
48/49	48.2	9	72	71.6	22	95/96	95	35
50/51	50	10	73/74	73.4	23	97/98	96.8	36
52/53	51.8	11	75/76	75.2	24	99	98.6	37
54	53.6	12	77/78	77	25			

Appendix 2: Configuration of Connection Pipe

1. Standard length of connection pipe (More details please refer to the specifications.)

2. Min length of connection pipe. For the unit with standard connection pipe of 5m, there is no limitation for the min length of connection pipe. For the unit with standard connection pipe of 7.5m and 8m, the min length of connection pipe is 3m.

3. Max. length of connection pipe and max. high difference. (More details please refer to the specifications.)

4. The additional refrigerant oil and refrigerant charging required after prolonging connection pipe

- After the length of connection pipe is prolonged for 10m at the basis of standard length, you should add 5ml of refrigerant oil for each additional 5m of connection pipe.
- The calculation method of additional refrigerant charging amount (on the basis of liquid pipe):
- Basing on the length of standard pipe, add refrigerant according to the requirement as shown in the table. The additional refrigerant charging amount per meter is different according to the diameter of liquid pipe. See the following sheet.
- Additional refrigerant charging amount = prolonged length of liquid pipe X additional refrigerant charging amount per meter

Additional refrigerant charging amount for R32			
Diameter of connection pipe		Outdoor unit throttle	
Liquid pipe	Gas pipe	Cooling only(g/m)	Cooling and heating(g/m)
Φ1/4"	Φ3/8" or Φ1/2"	12	16
Φ1/4" or Φ3/8"	Φ5/8" or Φ3/4"	12	40
Φ1/2"	Φ3/4" or Φ7/8"	24	96
Φ5/8"	Φ1" or Φ1 1/4"	48	96
Φ3/4"	/	200	200
Φ7/8"	/	280	280

Appendix 3: Pipe Expanding Method

⚠ Note:

Improper pipe expanding is the main cause of refrigerant leakage. Please expand the pipe according to the following steps:

A: Cut the pipe

- Confirm the pipe length according to the distance of indoor unit and outdoor unit.
- Cut the required pipe with pipe cutter.

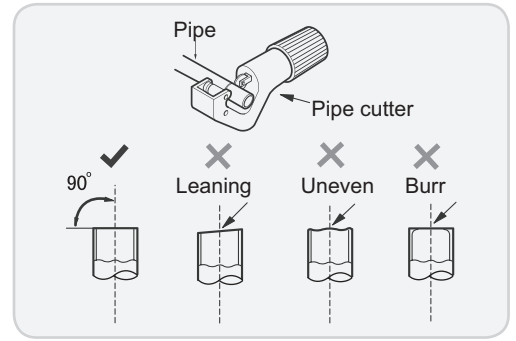

B: Remove the burrs

- Remove the burrs with shaper and prevent the burrs from getting into the pipe.

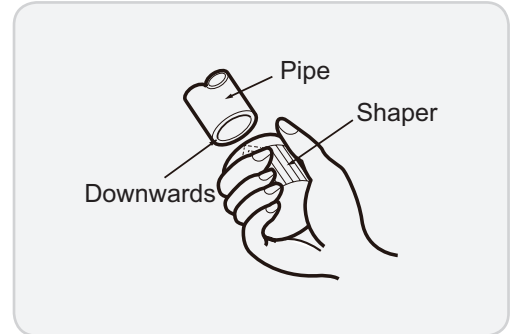

C: Put on suitable insulating pipe.

D: Put on the union nut

- Remove the union nut on the indoor connection pipe and outdoor valve; install the union nut on the pipe.

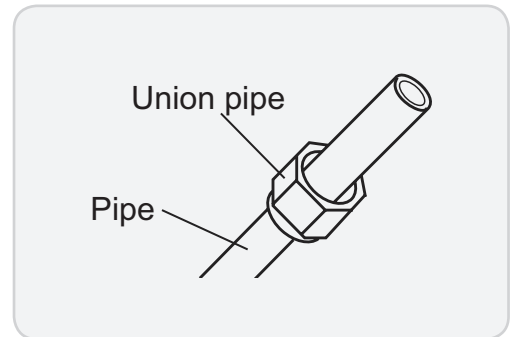

E: Expand the port

- Expand the port with expander.

⚠ Note:

- "A" is different according to the diameter, please refer to the sheet below:

Outer diameter(mm)	A(mm)	
	Max	Min
Φ6 - 6.35 (1/4")	1.3	0.7
Φ9 - Φ9.52 (3/8")	1.6	1.0
Φ12 - 12.70 (1/2")	1.8	1.0
Φ16 - 15.88 (5/8")	2.4	2.2

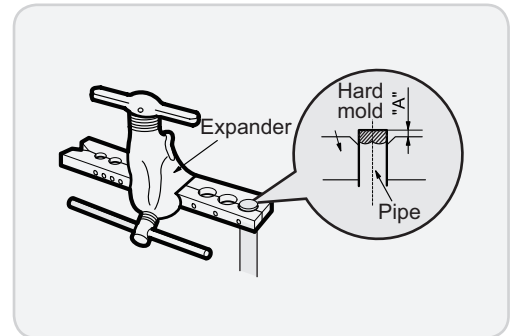

F: Inspection

- Check the quality of expanding port. If there is any blemish, expand the port again according to the steps above.

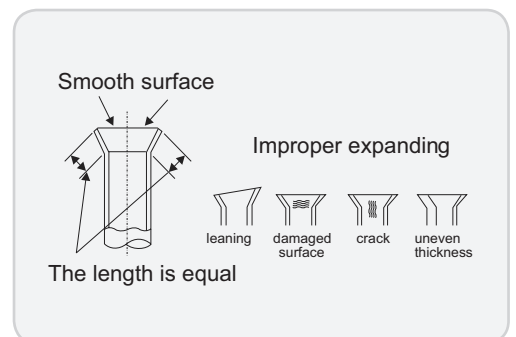

Appendix 4: List of Resistance for Temperature Sensor

Resistance Table of Ambient Temperature Sensor for Indoor and Outdoor Units(15K)

Temp(°C)	Resistance(kΩ)
-19	138.10
-18	128.60
-16	115.00
-14	102.90
-12	92.22
-10	82.75
-8	74.35
-6	66.88
-4	60.23
-2	54.31

Temp(°C)	Resistance(kΩ)
0	49.02
2	44.31
4	40.09
6	36.32
8	32.94
10	29.90
12	27.18
14	24.73
16	22.53
18	20.54

Temp(°C)	Resistance(kΩ)
20	18.75
22	17.14
24	15.68
26	14.36
28	13.16
30	12.07
32	11.09
34	10.20
36	9.38
38	8.64

Temp(°C)	Resistance(kΩ)
40	7.97
42	7.35
44	6.79
46	6.28
48	5.81
50	5.38
52	4.99
54	4.63
56	4.29
58	3.99

Resistance Table of Tube Temperature Sensors for Indoor and Outdoor (20K)

Temp(°C)	Resistance(kΩ)
-19	181.40
-15	145.00
-10	110.30
-5	84.61
0	65.37
5	50.87
10	39.87
15	31.47

Temp(°C)	Resistance(kΩ)
20	25.01
25	20.00
30	16.10
35	13.04
40	10.62
45	8.71
50	7.17
55	5.94

Temp(°C)	Resistance(kΩ)
60	4.95
65	4.14
70	3.48
75	2.94
80	2.50
85	2.13
90	1.82
95	1.56

Temp(°C)	Resistance(kΩ)
100	1.35
105	1.16
110	1.01
115	0.88
120	0.77
125	0.67
130	0.59
135	0.52

Resistance Table of Discharge Temperature Sensor for Outdoor(50K)

Temp(°C)	Resistance(kΩ)
-30	911.400
-25	660.8
-20	486.5
-15	362.9
-10	274
-5	209
0	161
5	125.1

Temp(°C)	Resistance(kΩ)
10	98
15	77.35
20	61.48
25	49.19
30	39.61
35	32.09
40	26.15
45	21.43

Temp(°C)	Resistance(kΩ)
50	17.65
55	14.62
60	12.17
65	10.18
70	8.555
75	7.224
80	6.129
85	5.222

Temp(°C)	Resistance(kΩ)
90	4.469
95	3.841
100	3.315
105	2.872
110	2.498
115	2.182
120	1.912
125	1.682



JF00305352



GREE ELECTRIC APPLIANCES, INC. OF ZHUHAI

Add: West Jinji Rd, Qianshan, Zhuhai, Guangdong, China, 519070
Tel: (+86-756) 8522219
Fax: (+86-756) 8669426
E-mail: global@cn.gree.com

For product improvement, specifications and appearance in this manual are subject to change without prior notice.